

Version CAN 2.2

Structural Screw Catalog

Limit States Design for Canada



Disclaimer

The information in this document is provided on an “as is” basis and for general information purposes only. While MTC Solutions aims to keep the information provided in this document complete, accurate, and in line with state-of-the-art design methods, MTC Solutions, its affiliates, employees, agents, or licensors do not make any representations or warranties of any kind, including, but not limited to, express or implied warranties of fitness for a particular purpose or regarding the content or information in this document, to the full extent permitted by applicable law.

The information in this document does not constitute engineering or other professional advice, and any reliance users place on such information is therefore strictly at their own risk. Images and drawings provided within this document are for reference only and may not apply to all possible conditions. MTC Solutions shall not be liable for any loss or damage of any kind, including indirect, direct, incidental, punitive, or consequential loss or damage arising out of, or in connection with, the information, content, materials referenced, or the use of any of the systems described in this document. Users may derive other applications which are beyond MTC Solutions’ control. The inclusion of the systems or the implied use of this document for other applications is beyond the scope of MTC Solutions’ responsibility.



Structural Screw Catalog

Limit States Design for Canada



Table of Contents

GENERAL NOTES TO THE DESIGNER	10
GENERAL NOTES TO THE INSTALLER	12
FASTENER DURABILITY	13
Fastener Steel and Coatings	14
CONNECTION CLASSIFICATION	15
Axial Connections	15
Lateral Connections	17
MTC STRUCTURAL FASTENER SELECTION PROCESS	19
MTC STRUCTURAL FASTENER OVERVIEW	20
PARTIALLY THREADED 4.0 FASTENER SERIES	23
ASSY Ecofast 4.0.....	24
ASSY SK 4.0.....	26
ASSY Kombi 4.0	29
ASSY Kombi LT 4.0	31
ASSY FWH 4.0	32
Factored and Specified Resistance Values	34
Geometry Requirements.....	36
FULLY THREADED FASTENER SERIES	39
ASSY VG CSK	40
ASSY VG CYL	42
ASSY VG RH	44
Factored and Specified Resistance Values	46
Geometry Requirements.....	48
STAINLESS STEEL FASTENER SERIES	51
ASSY A2 Ecofast	52
ASSY A2 SK.....	53
Specified Resistance Values.....	54
Geometry Requirements.....	55
SELF-DRILLING DOWELS	57
Self-Drilling Dowel.....	58
Specified Strength Values.....	58
Geometry Requirements.....	59

ACCESSORIES	61
90° Cup Washer	61
45° Wedge Washer	62
Predrilling Jig	63
Bits	63
Magnetic Hex Socket	64
Bit Holder Socket	64
Reverse-Head Socket	64
Magnetic Bit Case Holder VG RH	65
Magnetic Bit Case Holder SK, VG CSK	65
APPENDIX	67
Appendix A: General Connection Information	68
Appendix B: Additional Geometry Considerations	71
Appendix C: Steel Plate Detailing	76
Appendix D: Service Conditions and Durable Design	78
Appendix E: Installation Guidelines	87

Mass Timber Hardware Specialists



At MTC Solutions, our core focus is to supply structural hardware for modern mass timber applications in commercial, industrial, and residential projects. Our pride lies in collaborating with leading industry experts to offer design solutions and tools for code-compliant, sustainable buildings, continuously pushing the boundaries of the North American construction industry.

Our in-house team of mass timber specialists support professionals in designing customized connections that cater to the specific requirements of each project, resulting in truly innovative and cost-efficient solutions. With industry-recognized expertise and tested & proven solutions, we stand at the forefront of the industry, driving progress and innovation in mass timber construction.



Expertise

We provide our customers with the knowledge and tools necessary to construct cutting-edge, code-compliant mass timber projects while pushing the boundaries of the North American construction industry.



Commitment

We are dedicated to making your project a success, offering support from design and installation assistance to fast and precise delivery of high-quality products.



Products Tailored for North America

We partner with leading research facilities across North America to ensure that our products are tested and customized to meet the unique needs of the market, including seismic considerations and solutions for large post-and-beam structures in various climates.

Find Your Connection Solution

MTC Solutions provides the right tools to design code-compliant buildings, educating the mass timber industry on connection solutions.

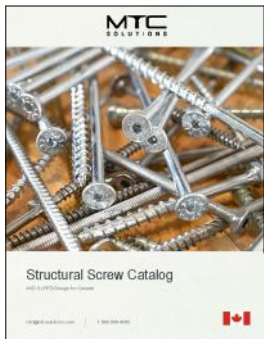

Structural Screw Catalog



Structural Screw Connection Design Guide



Structural Fasteners



Accessories

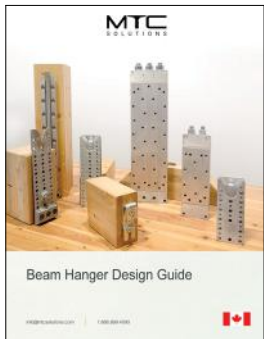

Beam Hanger Design Guide



Beam Hangers



Connector Design Guide



Connectors



Rigging Design Guide



Rigging Devices



Fall Arrest Anchor Design Guide



Fall Arrest

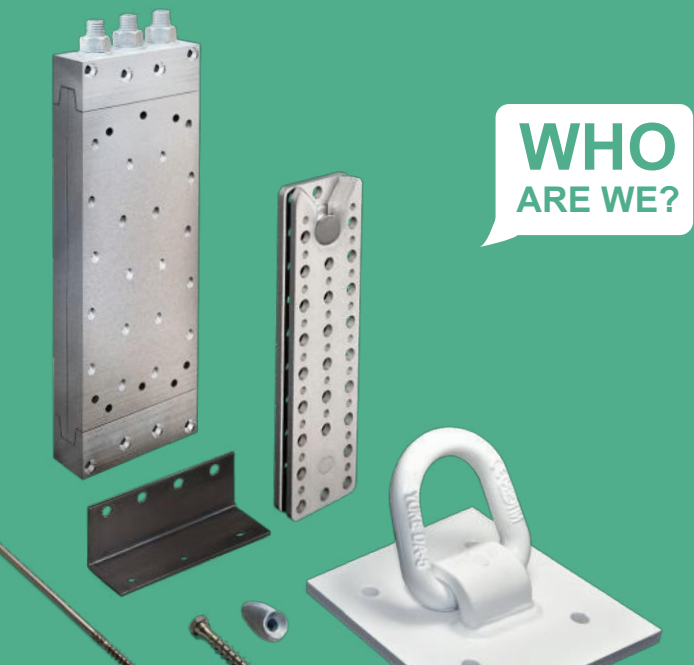

**WHO
ARE WE?**

YOUR MASS TIMBER HARDWARE SUPPLIER

Rely on our distribution team to deliver your North American projects with speed and accuracy.

LEADING WITH INNOVATION & RESEARCH

We are leading the mass timber industry with cutting-edge connection solutions and through partnerships with renowned research facilities.

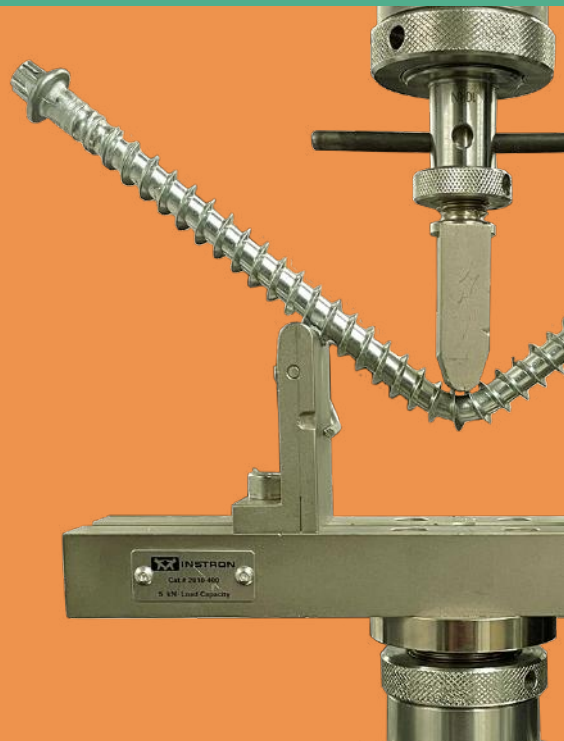

WE MAKE YOU THE EXPERT

Learn about the right solutions for your projects and mass timber connections with our technical resources & support team!

CONNECTIONS DESIGN SUPPORT

Reach out to the technical team for design support, from early design stages to ongoing iterative changes. We help find the most efficient connection solutions.



MANUFACTURERS' HELP DESK

Use our comprehensive & practical resources to find the most cost-effective solutions for your structural elements.



TESTED & PROVEN SOLUTIONS

Count on MTC Solutions' 10+ years of expertise, providing tested & proven ICC-ES-certified approved solutions, support, and resources.



General Notes to the Designer

1. All suggestions and details provided are general guidelines and cannot be assumed to be valid for all construction requirements and specific site conditions.
2. Specified resistances must be multiplied by all applicable modification factors and resistance factors specified in CSA O86:24 to determine factored resistances. Where factored withdrawal resistance values are presented in this guide, normal load duration and dry service conditions are assumed ($K_D = K_{SF} = 1.0$). If the connection conditions do not align with these assumptions, the factored resistance values must be multiplied by appropriate K_D and/or K_{SF} factors specified in CSA O86:24.
3. A load-bearing connection shall consist of at least two fasteners.
4. MTC Solutions fasteners are intended to be used where temperatures do not exceed 50°C, except for occasional exposures up to 65°C.
5. The load duration factor, K_D , does not apply to connections where capacity is controlled by metal or concrete/masonry strength.
6. Connections must respect the geometry requirements as specified in the respective detailing section for each series of fasteners.
7. For connections with multiple closely spaced fasteners, their capacity may be limited by the capacity of the surrounding wood. Applying the minimum geometry requirements does not prevent wood failure such as row tear-out, group tear out, block tear-out, net tension failure, or splitting perpendicular to grain caused by local stresses. These failures should be checked in accordance with CSA O86:24 Clauses 12.12.10.7 and 12.12.10.8. Refer to Appendix A: General Connection Information (Page 68) for additional information on brittle failure modes in wood.
8. The designer must ensure that all possible stress limits in the wood members, such as the shear capacity, the rolling shear capacity of the cross-laminated timber (CLT), or other material properties, are not exceeded while maintaining a continuous load path.
9. In wood species sensitive to splitting, the minimum geometry requirements may need to be increased to minimize the risk of splitting.
10. Different series of fasteners vary in specified tensile resistance, t_s , specified shear resistance, v_s , and specified yield strength in bending, f_y . These different fastener properties must be considered in the design, as they can influence the lateral resistance and withdrawal resistance of a fastener in a connection.
11. For a connection with multiple fasteners, the standard approach to calculate the resistance of the fasteners acting in withdrawal and the resistance of the fasteners acting in shear are associated with different stiffnesses and therefore cannot be added together to obtain the total capacity of the connection.
12. For a connection with multiple fasteners, only the capacities of the fasteners of the same diameter and exhibiting the same yield mode or governed by the same failure mode may be added together to obtain the total capacity of the connection. For example, the withdrawal capacity of a fastener cannot be added to the tension capacity of a fastener to obtain the total capacity of a connection.
13. Where steel side plate members are used, CSA 40.21 Grade 300W rolled plate is required at minimum.



14. Where steel side plate members are used, the resistance of the steel should exceed the stress induced in the steel side plate and at the bearing of the fasteners on the plate.
15. The embedment strength of self-tapping screws is determined in accordance with CSA O86:24 Clause 12.12.10.5.3.
16. The minimum member thickness, t , of lumber and timber members varies with the nominal fastener diameter, D , as follows:
 - For screws with $D = 6$ mm, $t \geq 24$ mm
 - For screws with $D = 8$ mm, $t \geq 30$ mm
 - For screws with $D = 10$ mm, $t \geq 40$ mm
 - For screws with $D = 12$ mm, $t \geq 80$ mm
17. The minimum member thickness, t , of structural wood panels, such as plywood or OSB, varies with the nominal fastener diameter, D , as follows:
 - For screws with $D = 6$ mm, $t \geq 12$ mm
 - For screws with $D = 8$ mm, $t \geq 16$ mm
 - For screws with $D = 10$ mm, $t \geq 20$ mm
 - For screws with $D = 12$ mm, $t \geq 24$ mm
18. Pilot holes are recommended for the following conditions to reduce the risk of splitting:
 - For species prone to splitting, including various species of spruce and fir, including Douglas Fir.
 - For lumber with thickness ≤ 38 mm (1-1/2 in.)
 - For laterally loaded screws installed in lumber with a thickness $\leq 7D$ ($\leq 14D$ for various species of spruce and fir, including Douglas Fir).
 - For axially loaded screws installed in lumber with a thickness $\leq 10D$ and/or a width of $< 8D$ or 60 mm (2-3/8 in.), whichever is greater.
19. The minimum penetration length of a fastener (excluding the tip length = D) with a nominal diameter, D , in the main member shall be:
 - 5D when loaded in shear
 - 4D when axially loaded installed in side grain
 - 20D when axially loaded in end grain
20. To ensure full connection resistance in CLT panels, it is recommended that fasteners penetrate panel plies to the largest extent possible.
21. For relative densities assigned to different timber species, refer to CSA O86:24 Table A.12.
22. A hole is considered to be predrilled if its length matches the entire length of the fastener. Refer to Appendix E: Installation Guidelines (Page 87) for more information on predrilling and pilot holes.
23. Predrilling is recommended for installation of fasteners into dry ($< 10\%$ MC) Southern Yellow Pine (SYP) to reduce installation torque.
24. The designer must consider corrosion resistance, service conditions, and the connection environment when specifying fasteners. See the Fastener Durability section (Page 13) and Appendix D: Service Conditions and Durable Design (Page 78) for additional information.
25. Carbon steel screws provided by MTC Solutions have core hardness less than 390 HV making them suitable for dry service conditions only (see CSA O86:24 Table 12.1). For wet service conditions, use stainless steel fasteners provided by MTC Solutions. Refer to the Fastener Durability section (Page 13) and Appendix D: Service Conditions and Durable Design (Page 78) for additional information.
26. The factored fastener resistances are permitted to be calculated using the equations presented in CSA O86:24 Section 12.12 or derived from approved testing. Refer to the footnotes within each design table for details on the sources of specified values.

General Notes to the Installer

1. Carbon steel fasteners shall only be used in dry service conditions, as exposure to wet service conditions may lead to premature failure. Refer to the Fastener Durability section (Page 13) and Appendix D: Service Conditions and Durable Design (Page 78) for additional information.
2. Connections designed for dry service conditions should be protected from excessive moisture during construction and in service.
3. Different types of fasteners vary in strength and corrosion resistance. Installers should avoid substituting one type of fastener for another without consulting a licensed design professional.
4. Unless indicated by the designer, do not overdrive the fasteners as it may lead to a reduction in connection resistance.
5. The maximum allowable insertion torque of the fasteners must be respected. Refer to the Specified Resistance Value tables for the maximum allowable insertion torque values.
6. Do not use impact drills for installation of MTC Solutions fasteners. For more information on drill selection, refer to Appendix E: Installation Guidelines (Page 87).
7. All the specified fasteners should be installed prior to loading the members.
8. If splitting of a wood member or fastener breakage is observed during or prior to fastener installation, the installation process must be stopped, a licensed design professional contacted immediately, and appropriate measures taken.
9. The use of fully threaded fasteners in green wood should be avoided to reduce the potential for wood cracking.
10. A pilot hole may be used to facilitate the installation of long self-tapping screws or when fasteners are being installed at an angle, near an edge, or in the end grain. Pilot holes should be deep enough to facilitate installation depending on the connection configuration. The pilot hole diameter must not exceed the minor diameter, D_m , of the fastener. For more information on pilot holes, refer to Appendix E: Installation Guidelines (Page 87).
11. Predrilling may also be required in cases involving unusually dry wood, dense wood, aged timber, end-grain installation, installation close to the edges of the wood members, and where large diameter fasteners are used. For more information on predrilling refer to Appendix E: Installation Guidelines (Page 87).
12. Predrilling will help reduce the insertion torque for self-tapping fasteners.
13. Predrilling is recommended for installing slender fasteners into Southern Yellow Pine (SYP).
14. To avoid increased torque peaks caused by stopping and restarting during the drive-in process, screws should be fully driven in an uninterrupted process until the head is lightly seated against the side member. If necessary, a torque wrench may be used to complete installation immediately after the initial insertion of the screw.

Fastener Durability

This section offers suggestions to help designers choose the most durable fastener for various service conditions. These guidelines are not exhaustive, and site-specific conditions may warrant differing levels of protection. These recommendations should be validated by a licensed design professional based on the anticipated exposure during the lifespan of the connection. CSA O86:24 Table 12.1 prohibits carbon steel screws with a core hardness above 360 HV for use in wet service. MTC carbon steel fasteners have a core hardness between 360 HV and 390 HV, and therefore shall only be used in dry service conditions.

Fasteners supplied by MTC Solutions meet ISO 2702 standards during the manufacturing process and have a hardness less than 390 HV in order to mitigate Internal Hydrogen Embrittlement (IHE). In addition, MTC Solutions utilizes post-manufacturing inspection techniques in accordance with ISO 4042 and ISO 15330 to verify our fasteners meet the hardness requirements outlined in CSA O86:24, which further mitigates the risk of a brittle HE failure.

Designers should consider service conditions and the associated demands for corrosion resistance, structural capacity, accessibility for periodic inspections, ease of fastener replacement, and cost when specifying fasteners. Improper material selection can negatively impact fastener strength and durability, leading to corrosion. For further details, refer to the additional information provided in Appendix D: Service Conditions and Durable Design (Page 78).

1.1 - Suggested Corrosion Resistance for Common Service Conditions

Service Conditions	Environment	Suggested Corrosion Resistance
Dry	Untreated Wood	Regular
	Preservative-treated Wood	Regular or High
	Fire Retardant-treated Wood	Regular or High
Wet	Untreated Wood	High
	Preservative-treated Wood	High
Increased Corrosion Risks	Marine / Salt Water Exposure	Extreme
	Exposure to Aggressive Chemicals	Extreme

Notes:

1. The corrosion resistance of the fastener must account for the interactions between moisture and specific treatment chemicals.
2. See the Fastener Steel and Coatings section on the following page for information on the corresponding types of fasteners available at MTC Solutions.

Fastener Steel and Coatings

MTC Solutions offers fasteners in three different types of steel and coating to accommodate different corrosion resistance requirements.

Regular Corrosion-Resistant Fasteners

Carbon Steel with Blue Passivated Zinc Surface Coating—A3K

Regular corrosion-resistance fasteners are fabricated from case-hardened carbon steel with a maximum core hardness of 390 HV in accordance with CSA O86:24. The blue passivated zinc alloy coating (8–12 microns in thickness) on high-performance carbon steel fasteners contains zinc and nickel, delivering standard corrosion protection. The electroplated surface coating is categorized as A3K and utilizes CrIII passivation in accordance with DIN EN ISO 4042 (which specifies the requirements for electroplated coatings and coating systems on steel fasteners) which corresponds to ISO4042/Zn8/An/T4. These fasteners are adequate for use in low-corrosive environments, such as dry service conditions.



High Corrosion-Resistant Fasteners

A2 Stainless Steel

A2 is a European designation for chromium–nickel austenitic stainless steel (corrosion resistant) with low carbon content and a copper addition. This grade is generally equivalent to Type 304 stainless steel in North America. As stainless steel is a softer metal than carbon steel, A2 stainless steel screws exhibit lower strengths compared to carbon steel screws, which must be accounted for in design. Predrilling may also be required for longer A2 stainless steel screws. These screws are adequate for use in corrosive environments, such as those involving wet service conditions in certain types of treated lumber.

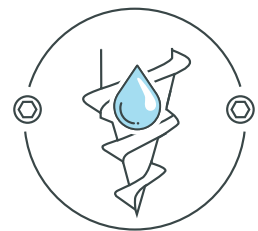

Extreme Corrosion-Resistant Fasteners

A4 Stainless Steel (Custom Order)

A4 is another European designation for chromium–nickel austenitic stainless steel (corrosion resistant) with low carbon content and a copper addition. This grade generally corresponds to Type 316 stainless steel in North America. A4 fasteners are adequate for use in more corrosive environments, such as those involving wet service conditions with the presence of salt water or other scenarios with increased corrosion risks.



MTC Solutions only supplies A4 stainless steel fasteners through custom orders. Clients are therefore advised to factor in an adequate lead time for their orders.

Connection Classification

Axial Connections

Connections with fasteners loaded axially in tension

These connections transfer axial tensile loads between side and main members with fasteners loaded axially in tension along their axis. Axial connections are typically designed for withdrawal and head pull-through in the wood members, as well as the tensile strength of the fasteners. The factored fastener resistances are permitted to be determined through the equations presented in CSA O86:24 Clause 12.12.8 or through approved testing. In this guide, the factored withdrawal resistance values are derived from Equation 1 as outlined in Evaluation Report CCMC 13677-R using K_D and K_{SF} of 1.0 for fasteners installed perpendicular to the shear plane ($\beta = 90^\circ$). Note that for fasteners installed at an angle to the shear plane of $30^\circ < \beta < 60^\circ$, withdrawal resistance can be improved by implementing the factor for dowel bearing effect, J_w , per CSA O86:24 Clause 12.12.8.2. For head pull-through resistance, the specified values from the CCMC report presented in this guide can be input into the factored head pull-through equation presented in CSA O86:24 Clause 12.12.8.3. The factored resistance, P_{rt} , of these connections is then taken as the minimum of:

- (a) $P_{rw,\alpha}$ factored withdrawal resistance of the fastener in the main member (i.e., the member containing the fastener tip), **(CCMC 13677-R)**
- (b) T_{rs} factored tensile resistance of the fastener, per Clause 12.12.8.4, and **(CSA O86:24)**
- (c) The greater of:
 - $P_{rw,\alpha}$ factored withdrawal resistance of the fastener in the side member, and **(CCMC 13677-R)**
 - P_{pt} factored head pull-through resistance, per Clause 12.12.8.3 **(CSA O86:24)**

$$P_{rw,\alpha} = \varphi \frac{0.8 \cdot \delta (b \cdot 0.84 \cdot \rho)^2 \cdot d \cdot l_{ef} \cdot 10^{-6}}{\sin^2 \alpha + \frac{4}{3} \cdot \cos^2 \alpha} \cdot K_D \cdot K_{SF} \quad (\text{N}) \quad (\text{eq. 1})$$

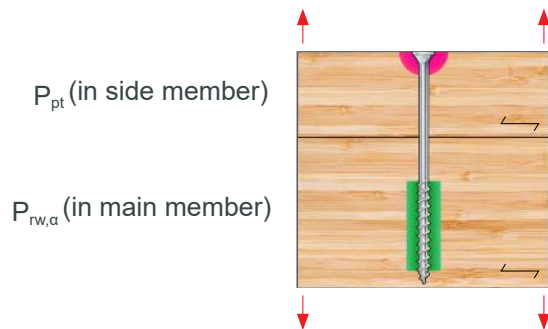

Partially Threaded Fastener in Axial Tension

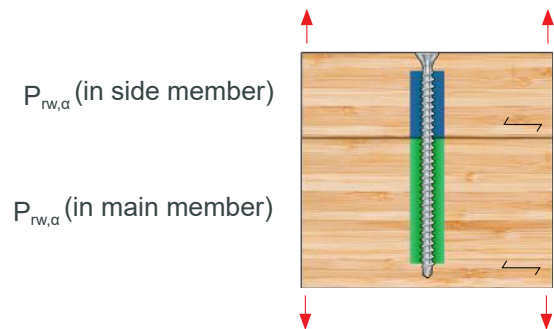

Fully Threaded Fastener in Axial Tension

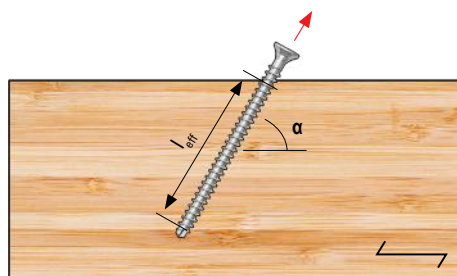

Withdrawal at an Angle of α to the Grain

- Notes:
- Where steel plate side members are used, the steel plate hole must be the correct size and the thickness of the steel plate shall be taken in consideration to ensure proper bearing of the fastener head.
 - Connections should meet requirements provided in the General Notes to the Designer section.
 - The examples represent single-fastener connections. However, in practice, all connections shall consist of at least two fasteners.
 - The tip of the fastener (equal to D in length) must be excluded from the effective length when calculating the withdrawal capacity of the fastener.

Connections with fasteners loaded axially in compression

These connections transfer axial compressive loads between side and main members with fasteners loaded axially in compression along their axis. A fastener is considered in withdrawal when it is pushed into the wood member under axial compression, just as it is when pulled out of the wood member under axial tension. The design of these connections is governed by the provisions in CSA O86:24 Clause 12.12.9. When a fastener is loaded axially in compression, its factored resistance, P_{rc} , is calculated as the minimum of:

- (a) P_{rw} factored withdrawal resistance, per Clause 12.12.8.2, and
- (b) P_{rb} factored buckling resistance, per Clause 12.12.9.2

For bearing reinforcement, the buckling resistance of screws is alternatively permitted to be determined by testing, which often yields higher design values than calculated results. Reference buckling resistance values for fully threaded fasteners are provided in Table 3.3 (Page 47).



Lateral Connections

Lateral connections with fasteners loaded in shear

These connections transfer lateral loads between side and main members with fasteners loaded in shear perpendicular to their axis. Lateral connections may offer ductile behavior if designed properly. The design of these connections is governed by the provisions in CSA O86:24 Clause 12.12.10.1, and requires evaluating the:

- N_r factored lateral yielding resistance, per Clause 12.12.10.5;
- V_{rs} factored shear resistance, per Clause 12.12.10.6;
- PB_r factored brittle failure resistance, per Clause 12.12.10.7;
- QS_{rT} factored lateral load perpendicular to grain, per Clause 12.12.10.8

See Appendix A: General Connection Information (Page 68) for further information.



Lateral Connection with a Fastener Loaded in Shear

Lateral connections with axially loaded inclined fasteners in tension

These connections transfer lateral loads between side and main members with fasteners loaded axially in tension at an angle to the wood fiber grain (α). Fasteners can be inclined at angles ranging from 30° to 60° to the shear plane ($30^\circ \leq \beta \leq 60^\circ$). Typically, fasteners are angled at 45° for these connections. Fasteners should be inclined to ensure the fasteners are loaded in tension only, and the connection should not be subjected to reverse loading. These connections with inclined fasteners are typically stiffer than connections with fasteners loaded in shear.

The design of these connections is governed by the provisions in CSA O86:24 Clause 12.12.10.2, and requires evaluating the:

- V_{rs} factored shear resistance of the screws, per Clause 12.12.10.6;
- P_{rt} factored resistance of screws loaded in tension, per Clause 12.12.8;
- PB_r factored brittle failure resistance, per Clause 12.12.10.7

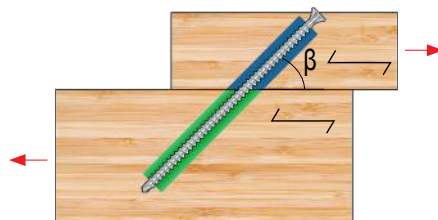

Lateral Connection with an Axially Loaded Inclined Screw

Lateral connections with axially loaded inclined fasteners in cross pairs

These connections transfer lateral loads between side and main members with pairs of fasteners installed at equal angles to the wood fiber grain in a cross configuration. Fasteners can be inclined at angles ranging from 30° to 60° to the shear plane ($30^\circ \leq \beta \leq 60^\circ$). Typically, fasteners are angled at 45° for these connections. This configuration is useful for bidirectional reverse loading. To be considered a cross pair, the fasteners should be installed at matching angles relative to the shear plane and have equal penetration. The point of intersection between the screw planes should occur within the length of the fastener. The fasteners ideally should cross at either the centroid of the side member or, alternatively, at the shear plane. The design of these connections is governed by the provisions in CSA O86:24 Clause 12.12.10.3, and requires evaluating the:

- V_{rs} factored shear resistance of screws, per Clause 12.12.10.6;
- P_{rt} factored resistance of screws loaded in tension, per Clause 12.12.8;
- P_{rc} factored resistance of screws loaded in compression, per Clause 12.12.9

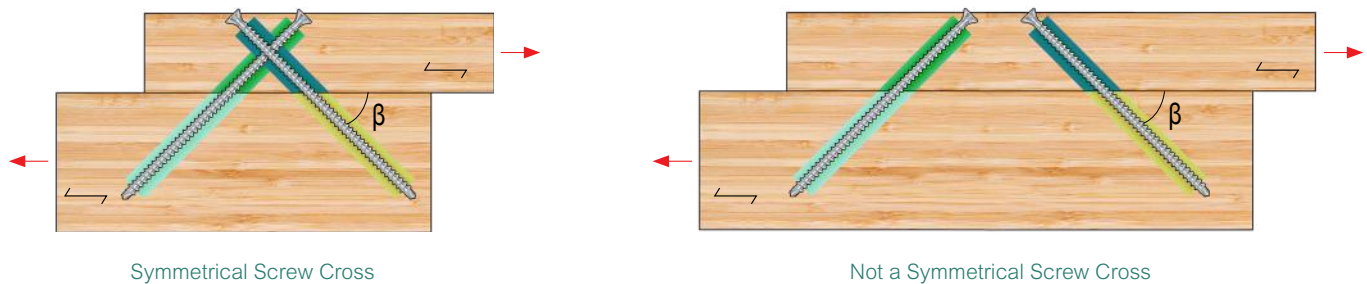

The screw resistance may be calculated by the CSA provisions noted above, or is alternatively permitted to be determined by testing. However, for cross pairs, CSA O86:24 Clause 12.12.10.3 states that the connection capacity should not be determined by summing the factored tension and compression resistance, P_{rt} and P_{rc} , respectively, but rather it should be limited to the minimum of:

- (a) $(2 \cdot P_{rt} \cdot \cos\beta)$ twice the factored tension resistance times $\cos\beta$;
- (b) $(2 \cdot P_{rc} \cdot \cos\beta)$ twice the factored compression resistance times $\cos\beta$;
- (c) $(V_{rs} / \sin\beta)$ the factored shear resistance divided by $\sin\beta$

Connections under combined lateral and withdrawal loading

For connections with fasteners perpendicular to the shear plane subjected to a combination of lateral and withdrawal loading, the provisions of CSA O86:24 Clause 12.12.11 shall be satisfied.

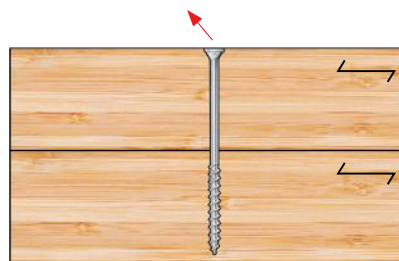

Connection Subjected to Combined Loading

MTC Structural Fastener Selection Process

Ensuring desired connection performance depends on choosing the appropriate screws for the project. Our comprehensive guide below facilitates quick navigation of available options and offers tips to aid selection. Individual project requirements may dictate alternative fasteners. It is advisable to consult with a licensed design professional to ensure the selection of the correct fasteners for the specific application.

Step 1: Fastener Series Selection

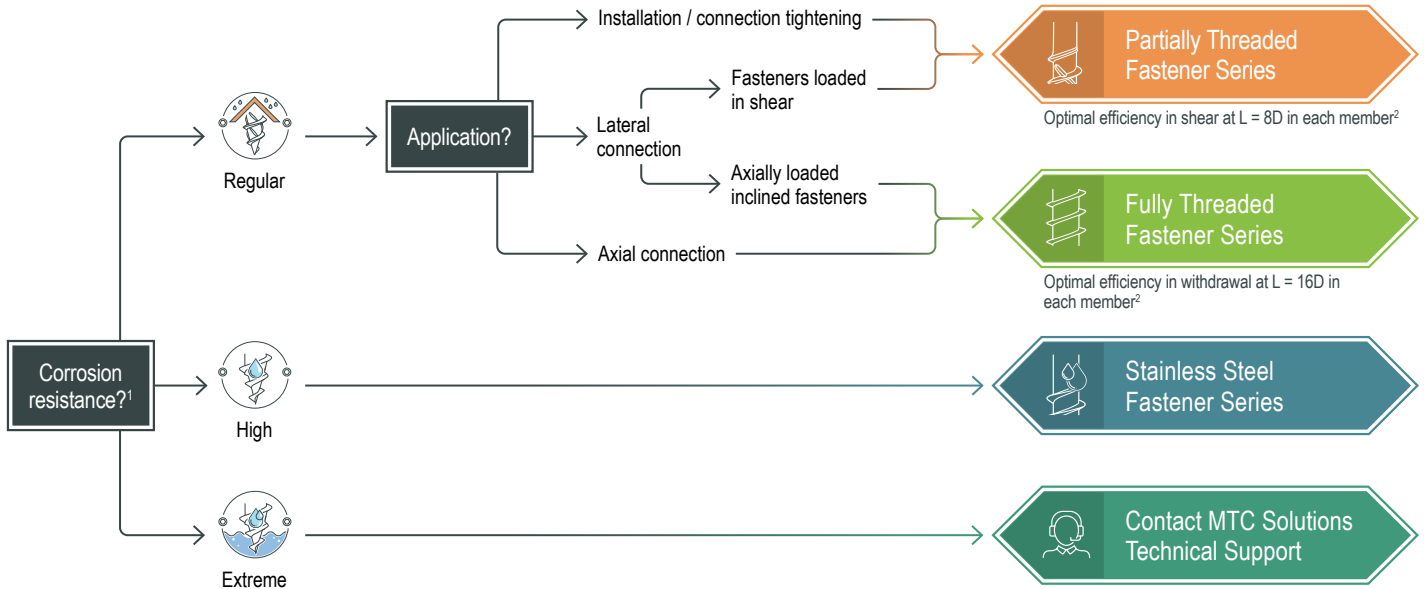

Notes: 1. See Appendix D: Service Conditions and Durable Design (Page 78) for more details on service conditions and corrosion resistance.

2. L and D are the thread penetration length and nominal diameter, respectively. This thread penetration length is only a rule of thumb.

Step 2: Fastener Model Selection¹

Architectural finish
 Best solution for this connection type
 Not ideal
 Best solution for wet service conditions

Fastener Type		Connection Type		Available Diameters				
		Wood-to-Wood	Steel-to-Wood	in. [mm]				
				1/4 [6]	5/16 [8]	3/8 [10]	1/2 [12]	9/16 [14]
Partially Threaded Fastener Series	Ecofast			✓	✓	✓		
	SK	★	○	✓	✓	✓	✓	
	Kombi	○	★		✓	✓	✓	
	FWH		○		✓			
Fully Threaded Fastener Series	VG CSK				✓	✓	✓	
	VG CYL	2			✓	✓		
	VG RH	2						✓
Stainless Steel Fastener Series	A2 Ecofast	💧		✓	✓			
	A2 SK	💧	○	✓	✓			

Notes: 1. The presented selection process serves as guidelines only. The final decision must be made by a licensed design professional.

2. For fasteners loaded in withdrawal, side-member resistance must be designed based on the thread penetration length.

MTC Structural Fastener Overview

Partially Threaded Fastener Series

Ecofast



Countersunk Head
Carbon Steel
Page 24



SK



Washer Head
Carbon Steel
Page 26



Kombi



Hexagonal Head
Carbon Steel
Page 29



Kombi LT



Hexagonal Head
Carbon Steel
Page 31



FWH



Flat Washer Head
Carbon Steel
Page 32



Fully Threaded Fastener Series

VG CSK



Countersunk Head
Carbon Steel
Page 40



VG CYL



Cylinder Head
Carbon Steel
Page 42



VG RH



Reverse Head
Carbon Steel
Page 44



Stainless Steel Fastener Series

A2 Ecofast



Countersunk Head
Stainless Steel
Page 52



A2 SK



Washer Head
Stainless Steel
Page 53



Self-Drilling Dowel

SDD



Cylinder Head
Carbon Steel
Page 58

Accessories

90° Cup Washer



Page 61

45° Wedge Washer



Page 62

Predrilling Jig



Page 63

Bits



Page 63

Magnetic Hex Socket



Page 64

Bit Holder Socket



Page 64

Reverse Head Socket



Page 64

Magnetic Bit Case Holder VG RH

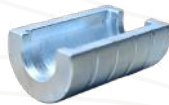

Page 65

Magnetic Bit Case Holder SK, VG CSK



Page 65



Philip J. Currie Dinosaur Museum

Wembley, Alberta

Partially Threaded 4.0 Fastener Series

MTC Solutions self-tapping Partially Threaded fasteners are designed to pull members tightly together, often utilized in situations where head pull-through capacity or lateral loading is a critical design consideration.



- 1/4 in. [6 mm]
 - 5/16 in. [8 mm]
 - 3/8 in. [10 mm]
 - 1/2 in. [12 mm]
- ℓ • 2 in. to 20-1/2 in. [50 mm to 520 mm]



Engineered Heads

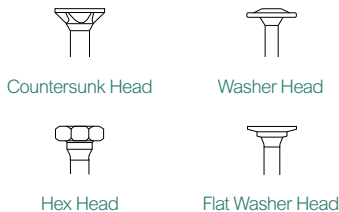

Case-Hardened Steel

A ductile core with a high-density layer on the edge, providing high bending yield strength & ductility



Coated Steel

Fasteners with a zinc and blue passivated coating for use in dry service conditions



Shank Cutter

Taps a larger hole for the unthreaded portion of the shank, reducing the insertion torque



Large Thread

Provides high withdrawal resistance



Reamer Tip

Reduces the need for predrilling and provides the quickest fastener wood bite

CERTIFICATIONS



Product Overview

ASSY Ecofast 4.0

Countersunk-Head Self-Tapping Wood Screw

The ASSY Ecofast is the classic fastener used to achieve a clean and flush architectural finish. Its reamer tip reduces wood splitting while offering quick wood fiber engagement.



Countersunk Head with Milling Pockets



Shank Cutter



Partially Threaded



Reamer Tip



Certifications ICC ESR-3179, CCMC 13677-R, ETA-11/0190

Connection Types Wood to Wood, Steel to Wood

Corrosion Resistance Regular

Hardness Compliance ≤ 390 HV per CSA O86:24

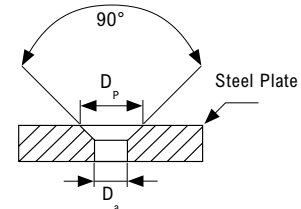
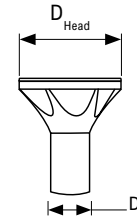
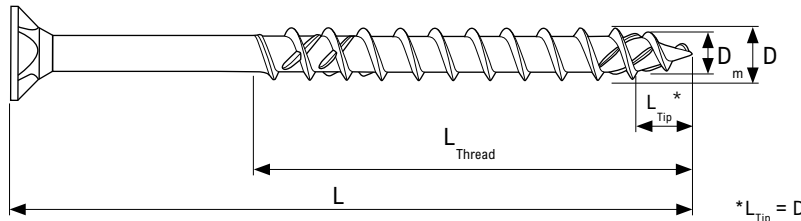

ASSY Ecofast 4.0 - 1/4 in. [6 mm] DIAMETER

Specification Item #	Packaging Qty.	D	L		L _{Thread}	D _{Head}	D _m	D _s	D _p	D _a	Drive Bit	
		in. [mm]	in. [mm]	[mm]	in. [mm]	in. [mm]						
[4] ECO0660	200	1/4 [6]	2-3/8	[60]	1-1/2	0.472 [12]	0.154 [3.9]	0.173 [4.4]	0.634 [16.1]	0.278 [7]	RW 40	
[4] ECO0670	200		2-3/4	[70]	1-5/8							[42]
[4] ECO0680	100		3-1/8	[80]	2							[50]
[4] ECO0690	100		3-1/2	[90]	2							[50]
[4] ECO06100	100		4	[100]	2-3/8							[60]
[4] ECO06120	100		4-3/4	[120]	2-3/4							[70]
[4] ECO06140	100		5-1/2	[140]	2-3/4							[70]
[4] ECO06160	100		6-1/4	[160]	2-3/4							[70]
[4] ECO06180	100		7-1/8	[180]	2-3/4							[70]
[4] ECO06200	100		7-7/8	[200]	2-3/4							[70]
[4] ECO06220	100		8-5/8	[220]	2-3/4							[70]
[4] ECO06240	100		9-1/2	[240]	2-3/4							[70]
[4] ECO06260	100		10-1/4	[260]	2-3/4							[70]
[4] ECO06280	100		11	[280]	2-3/4							[70]
[4] ECO06300	100		11-3/4	[300]	2-3/4							[70]

ASSY Ecofast 4.0 - 5/16 in. [8 mm] DIAMETER

Specification	Packaging Qty.	D	L	L _{Thread}	D _{Head}	D _m	D _s	D _p	D _a	Drive Bit
Item #		in. [mm]	in. [mm]	in. [mm]	in. [mm]					
[4] ECO0880	75	5/16 [8]	3-1/8 [80]	2 [50]	0.583 [15]	0.209 [5.3]	0.228 [5.8]	0.736 [18.7]	0.354 [9]	RW 40
[4] ECO0890	150		3-1/2 [90]	2-3/8 [60]						
[4] ECO08100	75		4 [100]	2-3/8 [60]						
[4] ECO08120	75		4-3/4 [120]	3-1/8 [80]						
[4] ECO08140	75		5-1/2 [140]	3-1/8 [80]						
[4] ECO08160	75		6-1/4 [160]	3-1/8 [80]						
[4] ECO08180	75		7-1/8 [180]	3-1/8 [80]						
[4] ECO08200	75		7-7/8 [200]	3-1/8 [80]						
[4] ECO08220	75		8-5/8 [220]	4 [100]						
[4] ECO08240	75		9-1/2 [240]	4 [100]						
[4] ECO08260	75		10-1/4 [260]	4 [100]						
[4] ECO08280	75		11 [280]	4 [100]						
[4] ECO08300	75		11-7/8 [300]	4 [100]						
[4] ECO08320	100		12-5/8 [320]	4 [100]						
[4] ECO08340	100		13-3/8 [340]	4 [100]						
[4] ECO08360	100		14-1/4 [360]	4 [100]						
[4] ECO08380	100		15 [380]	4 [100]						
[4] ECO08400	100	15-3/4 [400]	4 [100]							

ASSY Ecofast 4.0 - 3/8 in. [10 mm] DIAMETER

Specification	Packaging Qty.	D	L	L _{Thread}	D _{Head}	D _m	D _s	D _p	D _a	Drive Bit
Item #		in. [mm]	in. [mm]	in. [mm]	in. [mm]					
[4] ECO1080	50	3/8 [10]	3-1/8 [80]	2 [50]	0.728 [18.5]	0.256 [6.5]	0.283 [7.2]	0.889 [22.6]	0.433 [11]	RW 40
[4] ECO10100	50		4 [100]	2-3/8 [60]						
[4] ECO10120	50		4-3/4 [120]	3-1/8 [80]						
[4] ECO10140	50		5-1/2 [140]	3-1/8 [80]						
[4] ECO10160	50		6-1/4 [160]	4 [100]						
[4] ECO10180	50		7-1/8 [180]	4 [100]						
[4] ECO10200	50		7-7/8 [200]	4 [100]						
[4] ECO10220	50		8-5/8 [220]	4 [100]						
[4] ECO10240	50		9-1/2 [240]	4 [100]						
[4] ECO10260	50		10-1/4 [260]	4 [100]						
[4] ECO10280	50		11 [280]	4 [100]						
[4] ECO10300	50		11-7/8 [300]	4 [100]						
[4] ECO10320	50		12-5/8 [320]	4-3/4 [120]						
[4] ECO10360	50		14-1/4 [360]	4-3/4 [120]						
[4] ECO10400	50		15-3/4 [400]	4-3/4 [120]						





ASSY SK 4.0

Washer-Head Self-Tapping Wood Screw

The ASSY SK is engineered to support a high head pull-through capacity, making it a perfect fit for wood-to-wood applications. Its large head provides a high resistance to head pull-through.



Washer Head



Shank Cutter



Partially Threaded



Reamer Tip



Certifications	ICC ESR-3179, CCMC 13677-R, ETA-11/0190
Connection Types	Wood to Wood, Steel to Wood
Corrosion Resistance	Regular
Hardness Compliance	≤ 390 HV per CSA O86:24

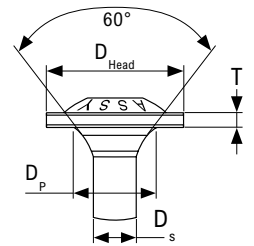
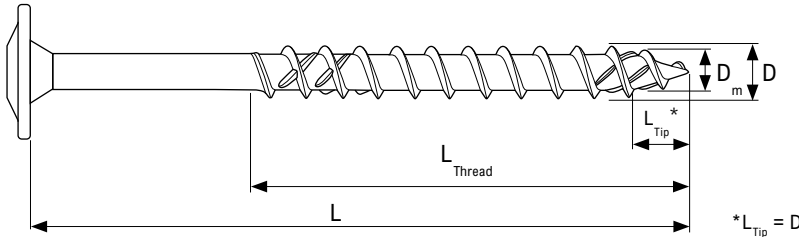

ASSY SK 4.0 - 1/4 in. [6 mm] DIAMETER

Specification Item #	Packaging Qty.	D	L	L _{Thread}	D _{Head}	D _m	D _s	D _p	T	Drive Bit
		in. [mm]	in. [mm]	in. [mm]	in. [mm]					
[4] SK0650	100	1/4 [6]	2 [50]	1-3/4 [45]	0.551 [14]	0.154 [3.9]	0.175 [4.4]	0.315 [8]	0.047 [1.2]	RW 40
[4] SK0660	100		2-3/8 [60]	1-1/2 [37]						
[4] SK0670	100		2-3/4 [70]	1-5/8 [42]						
[4] SK0680	100		3-1/8 [80]	2 [50]						
[4] SK0690	100		3-1/2 [90]	2 [50]						
[4] SK06100	100		4 [100]	2-3/8 [60]						
[4] SK06120	100		4-3/4 [120]	2-3/4 [70]						
[4] SK06140	100		5-1/2 [140]	2-3/4 [70]						
[4] SK06160	100		6-1/4 [160]	2-3/4 [70]						
[4] SK06180	100		7-1/8 [180]	2-3/4 [70]						
[4] SK06200	100		7-7/8 [200]	2-3/4 [70]						
[4] SK06220	100		8-5/8 [220]	2-3/4 [70]						
[4] SK06240	100		9-1/2 [240]	2-3/4 [70]						
[4] SK06260	100		10-1/4 [260]	2-3/4 [70]						
[4] SK06280	100		11 [280]	2-3/4 [70]						
[4] SK06300	100		11-7/8 [300]	2-3/4 [70]						

ASSY SK 4.0 - 5/16 in. [8 mm] DIAMETER

Specification	Packaging	D	L	L _{Thread}	D _{Head}	D _m	D _s	D _p	T	Drive Bit
Item #	Qty.	in. [mm]	in. [mm]	in. [mm]	in. [mm]					Drive Bit
[4] SK0860	50	5/16 [8]	2-3/8 [60]	2 [50]	0.870 [22.1]	0.209 [5.3]	0.228 [5.8]	0.394 [10]	0.071 [1.8]	RW 40
[4] SK0880	50		3-1/8 [80]	2 [50]						
[4] SK08100	50		4 [100]	2-3/8 [60]						
[4] SK08120	50		4-3/4 [120]	3-1/8 [80]						
[4] SK08140	50		5-1/2 [140]	3-1/8 [80]						
[4] SK08160	50		6-1/4 [160]	3-1/8 [80]						
[4] SK08180	50		7-1/8 [180]	3-1/8 [80]						
[4] SK08200	50		7-7/8 [200]	3-1/8 [80]						
[4] SK08220	50		8-5/8 [220]	4 [100]						
[4] SK08240	50		9-1/2 [240]	4 [100]						
[4] SK08260	50		10-1/4 [260]	4 [100]						
[4] SK08280	50		11 [280]	4 [100]						
[4] SK08300	50		11-7/8 [300]	4 [100]						
[4] SK08320	50		12-5/8 [320]	4 [100]						
[4] SK08340	50		13-3/8 [340]	4 [100]						
[4] SK08360	50		14-1/4 [360]	4 [100]						
[4] SK08380	50		15 [380]	4 [100]						
[4] SK08400	50		15-3/4 [400]	4 [100]						
[4] SK08420	50		16-1/2 [420]	4 [100]						
[4] SK08440	50		17-1/4 [440]	4 [100]						
[4] SK08480	25	19 [480]	4 [100]							
[4] SK08500	25	19-5/8 [500]	4 [100]							

ASSY SK 4.0 - 3/8 in. [10 mm] DIAMETER

Specification	Packaging	D	L	L _{Thread}	D _{Head}	D _m	D _s	D _p	T	Drive Bit
Item #	Qty.	in. [mm]	in. [mm]	in. [mm]	in. [mm]					Drive Bit
[4] SK10100	50	3/8 [10]	4 [100]	2-3/8 [60]	0.992 [25.2]	0.256 [6.5]	0.283 [7.2]	0.531 [13.5]	0.087 [2.2]	RW 50
[4] SK10120	50		4-3/4 [120]	3-1/8 [80]						
[4] SK10140	50		5-1/2 [140]	3-1/8 [80]						
[4] SK10160	50		6-1/4 [160]	4 [100]						
[4] SK10180	50		7-1/8 [180]	4 [100]						
[4] SK10200	50		7-7/8 [200]	4 [100]						
[4] SK10220	50		8-5/8 [220]	4 [100]						
[4] SK10240	50		9-1/2 [240]	4 [100]						
[4] SK10260	50		10-1/4 [260]	4 [100]						
[4] SK10280	50		11 [280]	4 [100]						
[4] SK10300	50		11-7/8 [300]	4 [100]						
[4] SK10320	50		12-5/8 [320]	4-3/4 [120]						
[4] SK10340	50		13-3/8 [340]	4-3/4 [120]						
[4] SK10360	50		14-1/4 [360]	4-3/4 [120]						
[4] SK10380	50		15 [380]	4-3/4 [120]						
[4] SK10400	50		15-3/4 [400]	4-3/4 [120]						
[4] SK10460	25		18-1/8 [460]	4-3/4 [120]						





ASSY SK 4.0 - 1/2 in. [12 mm] DIAMETER

Specification	Packaging Qty.	D	L	L _{Thread}	D _{Head}	D _m	D _s	D _p	T	Drive Bit
Item #		in. [mm]	in. [mm]	in. [mm]	in. [mm]					
[4] SK12200	25	1/2 [12]	7-7/8 [200]	4 [100]	1.157 [29.4]	0.283 [7.2]	0.323 [8.2]	0.552 [14]	0.102 [2.6]	RW 50
[4] SK12240	25		9-1/2 [240]	4-3/4 [120]						
[4] SK12260	25		10-1/4 [260]	4-3/4 [120]						
[4] SK12300	25		11-7/8 [300]	4-3/4 [120]						
[4] SK12400	25		15-3/4 [400]	5-3/4 [145]						
[4] SK12480	25		19 [480]	5-3/4 [145]						
[4] SK12520	25		20-1/2 [520]	5-3/4 [145]						



ASSY Kombi 4.0

Hex-Head Self-Tapping Wood Screw

The ASSY Kombi is specifically designed for high-performance steel-to-wood connections. Its reinforced and tapered shoulder has the same diameter as its thread, ensuring a tight fit in predrilled steel plate holes while reducing slip.

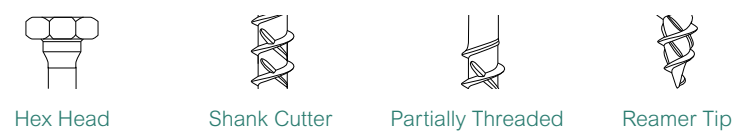

Certifications	ICC ESR-3179, CCMC 13677-R, ETA-11/0190
Connection Types	Steel to Wood
Corrosion Resistance	Regular
Hardness Compliance	≤ 390 HV per CSA O86:24

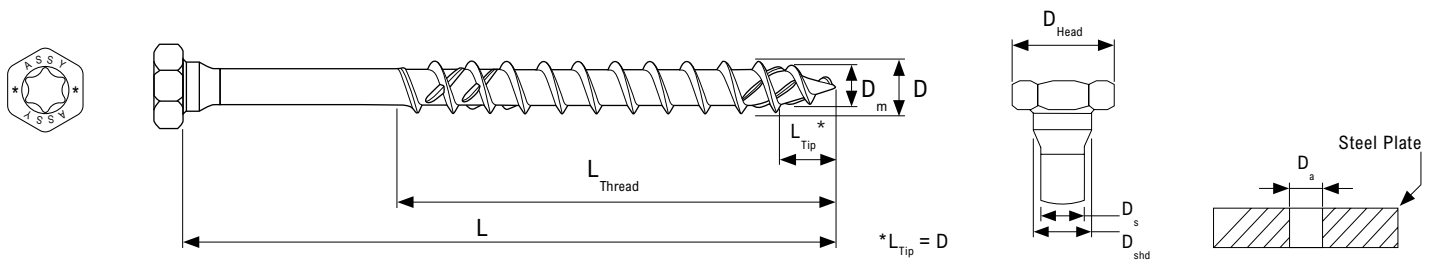

ASSY Kombi 4.0 - 5/16 in. [8 mm] DIAMETER

Specification	Packaging Qty.	D	L	L _{Thread}	D _{Head}	D _m	D _s	D _a	D _{shd}	Drive Bit
Item #		in. [mm]	in. [mm]	in. [mm]	in. [mm]					RW 40 or 1/2 Hex Socket
[4] KPT0860	75	5/16 [8]	2-3/8 [60]	1-1/2 [40]	0.472 [12]	0.209 [5.3]	0.228 [5.8]	0.354 [9]	0.315 [8]	
[4] KPT0880	75		3-1/8 [80]	2 [50]						
[4] KPT08100	75		4 [100]	2-3/8 [60]						
[4] KPT08120	75		4-3/4 [120]	3-1/8 [80]						
[4] KPT08140	75		5-1/2 [140]	3-1/8 [80]						
[4] KPT08160	75		6-1/4 [160]	3-1/8 [80]						
[4] KPT08180	75		7-1/8 [180]	3-1/8 [80]						
[4] KPT08200	75		7-7/8 [200]	3-1/8 [80]						
[4] KPT08240	75		9-1/2 [240]	4 [100]						
[4] KPT08300	75		11-7/8 [300]	4 [100]						

ASSY Kombi 4.0 - 3/8 in. [10 mm] DIAMETER

Specification	Packaging Qty.	D	L	L _{Thread}	D _{Head}	D _m	D _s	D _a	D _{shd}	Drive Bit
Item #		in. [mm]	in. [mm]	in. [mm]	in. [mm]					
[4] KPT1080	50	3/8 [10]	3-1/8 [80]	2 [50]	0.591 [15]	0.256 [6.5]	0.283 [7.2]	0.433 [11]	0.394 [10]	RW 40 or 19/32 Hex Socket
[4] KPT10100	50		4 [100]	2-3/8 [60]						
[4] KPT10120	50		4-3/4 [120]	3-1/8 [80]						
[4] KPT10140	50		5-1/2 [140]	3-1/8 [80]						
[4] KPT10160	50		6-1/4 [160]	4 [100]						
[4] KPT10180	50		7-1/8 [180]	4 [100]						
[4] KPT10200	50		7-7/8 [200]	4 [100]						
[4] KPT10300	50		11-7/8 [300]	4 [100]						

ASSY Kombi 4.0 - 1/2 in. [12 mm] DIAMETER

Specification	Packaging Qty.	D	L	L _{Thread}	D _{Head}	D _m	D _s	D _a	D _{shd}	Drive Bit
Item #		in. [mm]	in. [mm]	in. [mm]	in. [mm]					
[4] KPT12100	50	1/2 [12]	4 [100]	2-3/8 [60]	0.669 [17]	0.283 [7.2]	0.323 [8.2]	0.511 [13]	0.472 [12]	RW 40 or 11/16 Socket
[4] KPT12140	50		5-1/2 [140]	3-1/8 [80]						
[4] KPT12180	50		7-1/8 [180]	4 [100]						
[4] KPT12200	50		7-7/8 [200]	4 [100]						
[4] KPT12220	50		8-5/8 [220]	4-3/4 [120]						
[4] KPT12300	50		11-7/8 [300]	4-3/4 [120]						



ASSY Kombi LT 4.0

Hex-Head Self-Tapping Wood Screw

The ASSY Kombi LT is a long-threaded version of the ASSY Kombi, specifically designed for high-performance steel-to-wood connections. Its reinforced and tapered shoulder has the same diameter as its thread, ensuring a tight fit in predrilled steel plate holes while reducing slip.



Hex Head



Fully Threaded



Counter Thread Tip

Certifications

ICC ESR-3179, CCMC 13677-R, ETA-11/0190

Connection Types

Steel to Wood

Corrosion Resistance

Regular

Hardness Compliance

≤ 390 HV per CSA O86:24

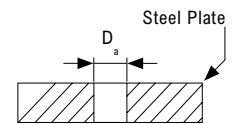
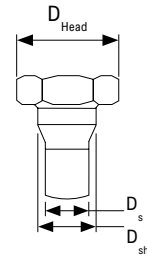
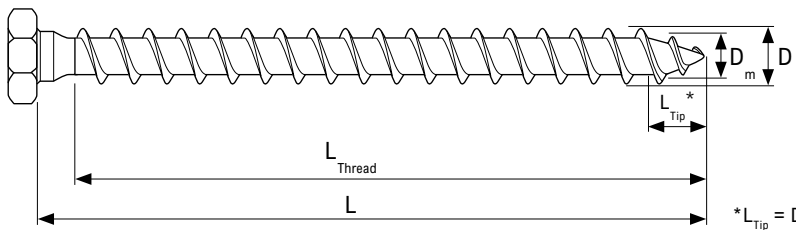

ASSY Kombi LT 4.0 - 1/2 in. [12 mm] DIAMETER

Specification	Packaging Qty.	D	L	L _{Thread}	D _{Head}	D _m	D _s	D _a	D _{shd}	Drive Bit
Item #		in. [mm]	in. [mm]	in. [mm]	in. [mm]					
[4] KLT1280	50	1/2 [12]	3-1/8 [80]	2-3/4 [70]	0.669 [17]	0.283 [7.2]	0.322 [8.2]	0.511 [13]	0.472 [12]	RW 40 or 11/16 Socket
[4] KLT12120	50		4-3/4 [120]	4 [100]						
[4] KLT12160	50		6-1/4 [160]	5-3/4 [145]						

ASSY FWH 4.0

Flat Washer-Head Self-Tapping Wood Screw

The ASSY FWH is a multi-purpose fastener that combines the pulling power of the washer-head screw with the clean flush finish of the countersunk-head screw. It is engineered to accommodate multilayer connections and roof membrane applications.

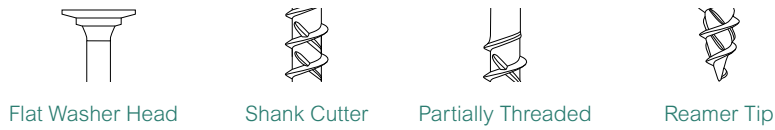

Certifications	ICC ESR-3179, ETA-11/0190
Connection Types	Wood to Wood
Corrosion Resistance	Regular
Hardness Compliance	≤ 390 HV per CSA O86:24

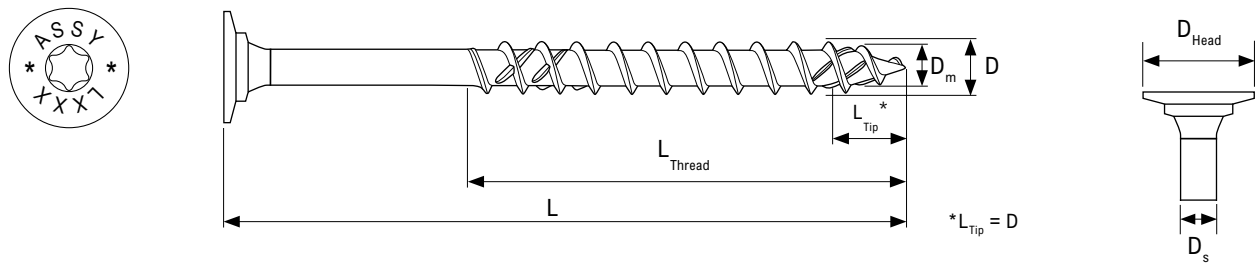

ASSY FWH 4.0 - 5/16 in. [8 mm] DIAMETER

Specification	Packaging Qty.	D	L	L _{Thread}	D _{Head}	D _m	D _s	Drive Bit
Item #		in. [mm]	in. [mm]	in. [mm]	in. [mm]			
[4] FWH08080	50	5/16 [8]	3-1/8 [80]	2 [50]	0.724 [18.4]	0.209 [5.3]	0.228 [5.8]	RW 40
[4] FWH08100	50		4 [100]	2-3/8 [60]				
[4] FWH08160	50		6-1/4 [160]	3-1/8 [80]				
[4] FWH08200	50		7-7/8 [200]	3-1/8 [80]				
[4] FWH08240	50		9-1/2 [240]	4 [100]				
[4] FWH08300	50		11-7/8 [300]	4 [100]				
[4] FWH08360	50		14-1/4 [360]	4 [100]				
[4] FWH08400	50		15-3/4 [400]	4 [100]				



Bayview Elementary School

Vancouver, British Columbia

Factored and Specified Resistance Values

Fastener resistances are permitted to be determined through the equations presented in CSA O86:24 Section 12.12 or through approved testing. In this guide, the factored withdrawal resistance values are derived directly from Evaluation Report CCMC 13677-R. Specified head pull-through resistance, tensile resistance, and shear resistance values are presented in accordance with tested values and should be input into appropriate CSA equations for factored resistance. Refer to the footnotes within each design table and the Connection Classification section (Page 15) for further information.

2.1 - Factored Withdrawal Resistance, $P_{rw,\alpha}$, per mm Thread Penetration Length for Partially Threaded Fastener 4.0 Series

Diameter in. [mm]	$P_{rw,\alpha}$ [N/mm]						
	Relative Density, G						
	Lumber & Glulam						PSL
	G = 0.35	G = 0.42	G = 0.44	G = 0.47	G = 0.49	G = 0.55	ESG ≥ 0.50
1/4 [6]	32	46	48	55	60	76	35
5/16 [8]	42	61	65	74	80	101	47
3/8 [10]	53	76	81	92	100	126	59
1/2 [12]	63	91	97	110	120	151	70

Notes:

- The factored resistance values in this table are derived from the equation presented in CCMC 13677-R (Eq. 1 on Page 15) and must be multiplied by the effective thread penetration length, l_{eff} , in mm to obtain the total factored withdrawal resistance for the fastener.
- CCMC 13677-R reports on results for Ecofast, SK, and Kombi partially threaded fasteners. Factored withdrawal resistance values may also be attributed to FWH as the same thread pattern exists.
- The factored resistance values apply to fasteners installed perpendicular to the grain of the wood member. For fasteners installed at an angle to the wood grain, α , values must be divided by the denominator of Eq. 1 on Page 15.
- The factored resistance values presented in this table are calculated using $K_D = 1.0$ and $K_{SF} = 1.0$. For all other load duration and service conditions, values must be multiplied by appropriate K_D and/or K_{SF} specified in CSA O86:24 Clause 12.2.1.7.
- G refers to the relative density assigned to the wood species. ESG must be the equivalent specific gravity given in the product specifications of PSL.
- Connection design must meet all relevant requirements outlined in the General Notes to the Designer section.

2.2 - Specified Head Pull-Through Resistance, f_{pt} , for Partially Threaded Fastener 4.0 Series

Diameter in. [mm]	Fastener Type	f_{pt} [kN]				
		Relative Density, G				
		Lumber & Glulam				PSL
		G = 0.35	G = 0.42	G = 0.49	G = 0.55	ESG \geq 0.50
1/4 [6]	Ecofast	1.70	2.08	2.48	2.82	3.35
	SK	3.12	3.82	4.55	5.20	5.62
5/16 [8]	Ecofast	2.39	2.96	3.54	4.06	4.18
	SK	5.24	6.51	7.71	8.75	9.35
	Kombi / Kombi LT	1.86	2.40	2.98	3.51	4.16
	FWH	—	5.18	6.13	—	—
3/8 [10]	Ecofast	3.14	4.07	4.92	5.68	6.50
	SK	6.55	7.57	8.43	9.07	10.18
	Kombi / Kombi LT	2.87	3.55	4.18	4.71	5.36
1/2 [12]	SK	6.60	8.01	9.42	10.65	11.99
	Kombi / Kombi LT	3.28	3.89	4.48	4.98	6.05

Notes:

- The specified head pull-through values presented in this table are the 5th percentile test value with a confidence interval of 75% in accordance with CSA O86:24 Clause 17.6.2.5.
- Minimum wood member thickness are specified in Note 16 in the General Notes to the Designer section (Page 10).
- Connection design must meet all relevant requirements outlined in the General Notes to the Designer section.
- G refers to the relative density assigned to the wood species. ESG must be the equivalent specific gravity given in the product specifications of PSL. For G=0.44 and G=0.47, values for G=0.42 may be used.
- The specified head pull-through resistance values, f_{pt} , are applicable to screws installed perpendicular to the faces of the wood members and must be multiplied by all modification factors included in CSA O86:24 Clause 12.2.1.7.
- The factored head pull-through resistance should be calculated per CSA O86:24 Clause 12.12.8.3.

2.3 - Specified Strength and Resistance Values for Partially Threaded Fastener 4.0 Series

Diameter in. [mm]	Specified Yield Strength f_y [MPa]	Specified Tensile Resistance t_s [kN]	Specified Shear Resistance v_s [kN]	Allowable Insertion Torque [N · m]
1/4 [6]	1,168	11.32	7.38	6.67
5/16 [8]	1,134	18.85	12.84	15.33
3/8 [10]	1,106	28.37	20.30	30.00
1/2 [12]	1,146	40.96	26.65	43.33

Notes:

- Connection design must meet all relevant requirements outlined in the General Notes to the Designer section.
- The specified yield strength values presented in this table are per ICC-ESR 3179 2021.
- The allowable insertion torque is determined in accordance with EAD 130118-01-0603, where the ratio of the torsional strength to the insertion torque should be at least 1.5.
- The specified tensile and shear resistance values presented in this table are the 5th percentile test value with a confidence interval of 75% in accordance with CSA O86:24 Clauses 17.6.2.2 and 17.6.2.3.
- The factored tensile resistance shall be calculated in accordance with CSA O86:24 Clause 12.12.8.4.
- The factored shear resistance shall be calculated in accordance with CSA O86:24 Clause 12.12.10.6.

Geometry Requirements

Glulam & Timber

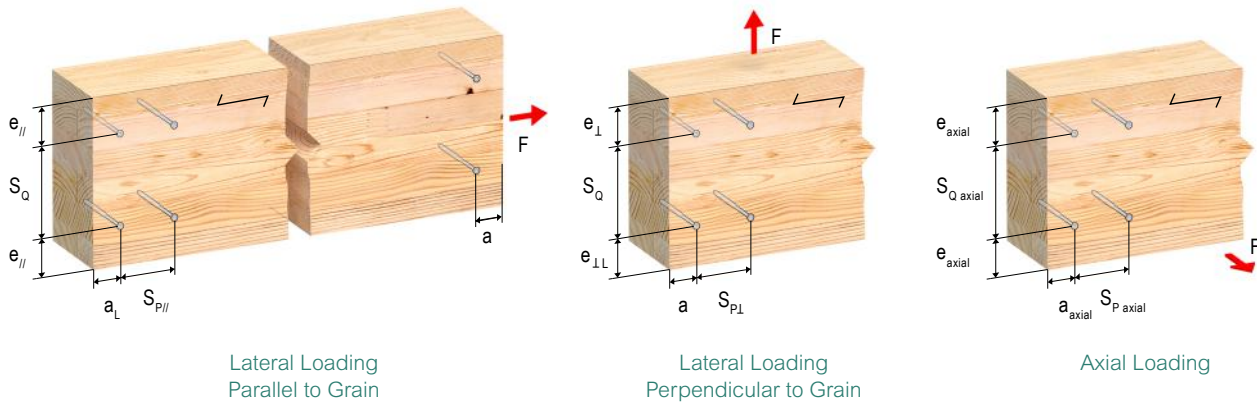

2.4 - Geometry Requirements for Partially Threaded Self-Tapping Screws 4.0 Series in Glulam and Timber

Loading Configuration		Installation Configuration			
		Glulam & Timber			
		Self-Tapping Screws		Predrilled	
		$G \leq 0.44$	$0.44 < G \leq 0.5$	Any G	
End Distance	Lateral loading parallel to grain in tension	a_L	15D**	22D	12D*
	Lateral loading parallel to grain in compression	a	10D**	15D	7D*
	Lateral loading perpendicular to grain	a	10D**	15D	7D*
	Axial loading	a_{axial}	10D*	10D*	10D*
Edge Distance	Lateral loading parallel to grain	$e_{//}$	5D	7D	3D
	Lateral loading perp. to grain, towards edge	$e_{\perp L}$	10D	12D	7D
	Lateral loading perp. to grain, away from edge	e_{\perp}	5D	7D	3D
	Axial loading	e_{axial}	4D	4D	4D
Spacing Between Fasteners in a Row [parallel to grain]	Lateral loading parallel to grain	$S_{P//}$	12D**	18D	5D*
	Lateral loading perpendicular to grain	$S_{P\perp}$	12D**	18D	5D*
	Axial loading	$S_{P\ axial}$	7D*	7D*	7D*
Spacing Between Rows [perpendicular to grain]	Lateral loading parallel to grain	S_Q	5D	7D	4D
	Lateral loading; staggered rows	S_{Qs}	2.5D	2.5D	—
	Axial loading	$S_{Q\ axial}$	5D	5D	5D

* For Douglas Fir-Larch and Western Red Cedar, this minimum spacing shall be increased by 50%

**For Western Red Cedar, this minimum spacing shall be increased by 50%

Notes:

- All connection design must meet all the relevant requirements outlined in the General Notes to the Designer section.
- Values for spacing between staggered rows apply where fasteners in adjacent rows are offset by half of the spacing between fasteners in a row.
- Within a row, fasteners may be staggered up to 2D to further reduce the potential for splitting.
- The geometry requirements for staggered rows are per ESR 3179. All remaining geometry requirements are per CSA O86:24 Clause 12.12.5.
- The minimum geometry requirements outlined in this section are meant to provide sufficient end and edge distances, as well as spacings between rows and between fasteners in a row, to reduce the potential for splitting.
- Applying the minimum requirements does not prevent wood failure, such as row tear-out, group tear-out, block tear-out, net tension failure, or splitting perpendicular to grain.

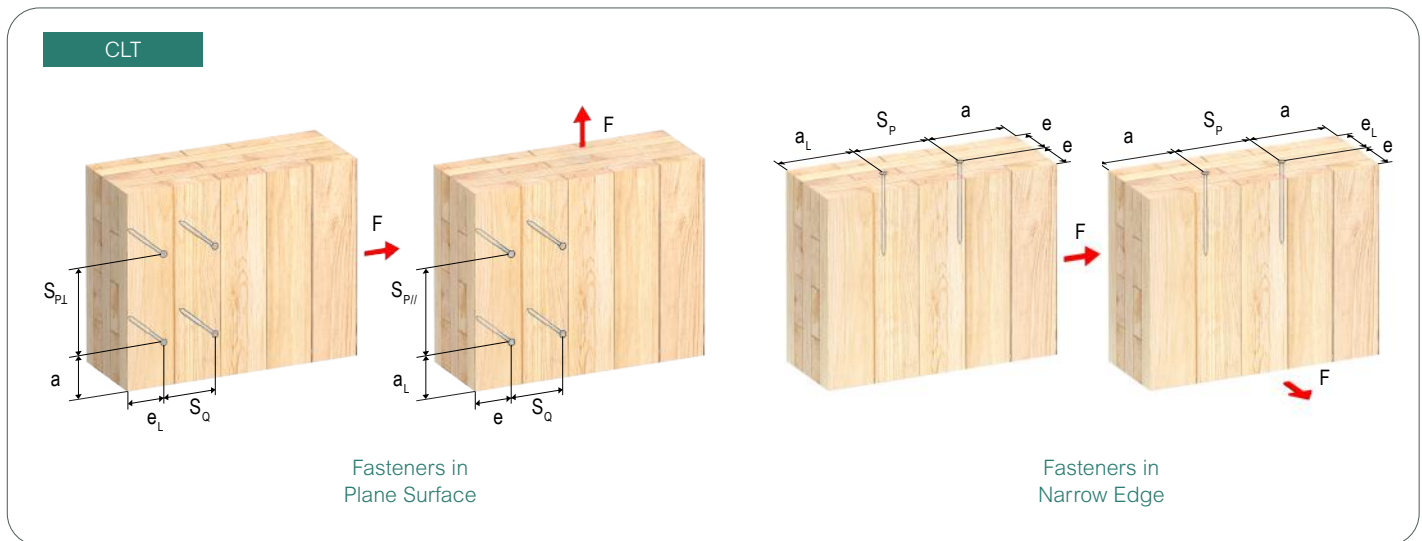

2.5 - Geometry Requirements for Partially Threaded Self-Tapping Screws 4.0 Series in CLT

Loading Configuration			Installation Configuration CLT [$G = 0.42$]	
			Surface	Edge
End Distance	Lateral loading parallel to grain in tension	a_L	6D	12D
	Lateral loading parallel to grain in compression	a	6D	7D
	Lateral loading perpendicular to grain	a	6D	7D
	Axial loading	a_{axial}	6D	7D
Edge Distance	Lateral loading parallel to grain	$e_{//}$	2.5D	3D
	Lateral loading perp. to grain, towards edge	$e_{\perp L}$	6D	6D
	Lateral loading perp. to grain, away from edge	e_{\perp}	2.5D	3D
	Axial loading	e_{axial}	2.5D	3D
Spacing Between Fasteners in a Row [parallel to grain]	Lateral loading parallel to grain	$S_{P//}$	4D	10D
	Lateral loading perpendicular to grain	$S_{P\perp}$	4D	10D
	Axial loading	$S_{P axial}$	4D	10D
Spacing Between Rows [perpendicular to grain]	Lateral loading parallel to grain	S_Q	2.5D	4D
	Axial loading	$S_{Q axial}$	2.5D	4D

Notes:

- All connection design must meet all the relevant requirements outlined in the Notes to the Designer section.
- For species prone to splitting (e.g., Douglas Fir and Hem-Fir), it is recommended that the parallel-to-grain spacing requirements be increased by 50%.
- Within a row, fasteners may be staggered up to 2D to further reduce the potential for splitting.
- The listed values are applicable when the CLT panel thickness is at least 10D.
- The minimum penetration length of the screw into the narrow face of the panel shall be 10D.
- The values provided are in accordance with ETA-11/0190.
- The minimum geometry requirements outlined in this table are meant to provide sufficient end and edge distances, as well as spacings between fasteners, to reduce the potential for splitting.
- Applying the minimum requirements does not prevent wood failure, such as row tear-out, group tear-out, block tear-out, net tension failure, or splitting perpendicular to grain.



First Tech Federal Credit Union

Hillsboro, Oregon

Fully Threaded Fastener Series

MTC Solutions self-tapping Fully Threaded fasteners are designed to hold wood members firmly in place, often utilized to take advantage of their high withdrawal capacity during axial loading.



- 1/4 in. [6 mm]
 - 5/16 in. [8 mm]
 - 3/8 in. [10 mm]
 - 1/2 in. [12 mm]
 - 9/16 in. [14 mm]
- ℓ • 3-1/8 in. to 59 in. [80 mm to 1500 mm]



Engineered Heads



Countersunk Head



Cylinder Head



Reverse Head



Case-Hardened Steel

A ductile core with a high density layer on the edge, providing high bending yield strength & ductility



Coated Steel

Fasteners with a zinc and blue passivated coating for use in dry service conditions



Large Thread

Provides high withdrawal resistance



Drilling Tip

Reduces both the need for predrilling and the typical geometry requirements

CERTIFICATIONS



ICC-ESR-3178



13677-R

ISO 50001

Energy Management System



ETA-11/0190

Product Overview

ASSY VG CSK

Countersunk-Head Self-Tapping Wood Screw

The ASSY VG CSK is a multi-purpose fastener, suitable for wood reinforcement as well as wood-to-wood and steel-to-wood connections.



Countersunk Head with Milling Pockets



Fully Threaded



Drilling Tip

Certifications	ICC ESR-3178, CCMC 13677-R, ETA-11/0190
Connection Types	Wood to Wood, Steel to Wood, Concrete to Wood
Corrosion Resistance	Regular
Hardness Compliance	≤ 390 HV per CSA O86:24

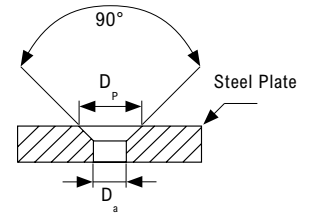
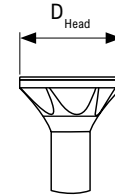
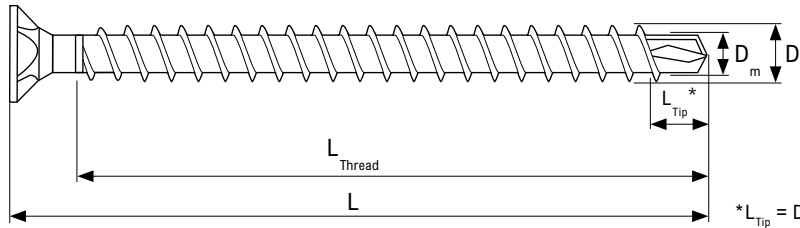
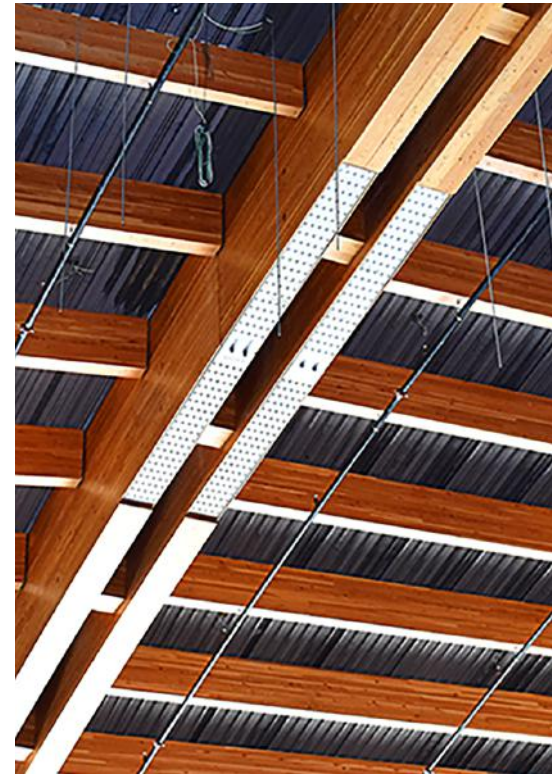

ASSY VG CSK - 5/16 in. [8 mm] DIAMETER

Specification	Packaging Qty.	D	L	L _{Threat}	D _{Head}	D _m	D _a	D _p	Drive Bit
Item #		in. [mm]	in. [mm]	in. [mm]	in. [mm]				
CSK0880	75	5/16 [8]	3-1/8 [80]	2-1/2 [61]	0.583 [15]	0.197 [5]	0.354 [9]	0.736 [18.7]	RW 40
CSK08120	75		4-3/4 [120]	4 [103]					
CSK08140	75		5-1/2 [140]	4-7/8 [123]					
CSK08160	75		6-1/4 [160]	5-5/8 [143]					
CSK08180	75		7-1/8 [180]	6-3/8 [163]					
CSK08200	75		7-7/8 [200]	7-1/4 [183]					
CSK08220	75		8-5/8 [220]	8 [203]					
CSK08240	75		9-1/2 [240]	8-3/4 [223]					
CSK08260	75		10-1/4 [260]	9-5/8 [243]					
CSK08280	75		11 [280]	10-3/8 [263]					
CSK08300	75		11-7/8 [300]	11-1/8 [283]					

ASSY VG CSK - 3/8 in. [10 mm] DIAMETER

Specification	Packaging Qty.	D	L	L _{Thread}	D _{Head}	D _m	D _a	D _p	Drive Bit
Item #		in. [mm]	in. [mm]	in. [mm]	in. [mm]				
CSK10100	50	3/8 [10]	4 [100]	3 [77]	0.774 [20]	0.244 [6.2]	0.433 [11]	0.984 [25]	RW 50
CSK10120	50		4-3/4 [120]	4-1/8 [102]					
CSK10140	50		5-1/2 [140]	4-7/8 [125]					
CSK10160	50		6-1/4 [160]	5-3/4 [145]					
CSK10180	50		7-1/8 [180]	6-1/2 [165]					
CSK10200	50		7-7/8 [200]	7-1/4 [185]					
CSK10220	50		8-5/8 [220]	8-1/8 [205]					
CSK10240	50		9-1/2 [240]	8-7/8 [225]					
CSK10260	50		10-1/4 [260]	9-5/8 [245]					
CSK10280	50		11 [280]	10-3/8 [265]					
CSK10300	50		11-7/8 [300]	11-1/4 [285]					
CSK10320	50		12-5/8 [320]	12 [305]					
CSK10340	50		13-3/8 [340]	12-3/4 [325]					
CSK10360	50		14-1/4 [360]	13-5/8 [345]					
CSK10380	50		15 [380]	14-3/8 [365]					
CSK10400	50		15-3/4 [400]	15-1/8 [385]					
CSK10430	25		16-7/8 [430]	16-3/8 [415]					
CSK10480	25		19 [480]	18-1/4 [465]					
CSK10530	25		20-7/8 [530]	20-1/8 [512]					
CSK10580	25		22-7/8 [580]	22-1/8 [562]					
CSK10650	25	25-5/8 [650]	24-7/8 [632]						
CSK10700	25	27-5/8 [700]	26-7/8 [682]						
CSK10750	25	29-1/2 [750]	28-7/8 [732]						
CSK10800	25	31-1/2 [800]	30-3/4 [782]						

ASSY VG CSK - 1/2 in. [12 mm] DIAMETER

Specification	Packaging Qty.	D	L	L _{Thread}	D _{Head}	D _m	D _a	D _p	Drive Bit
Item #		in. [mm]	in. [mm]	in. [mm]	in. [mm]				
CSK12120	50	1/2 [12]	4-3/4 [120]	4-1/8 [105]	0.868 [22]	0.280 [7.1]	0.512 [13]	1.063 [27]	RW 50
CSK12140	50		5-1/2 [140]	4-7/8 [125]					
CSK12160	50		6-1/4 [160]	5-3/4 [145]					
CSK12180	50		7-1/8 [180]	6-1/2 [165]					
CSK12200	50		7-7/8 [200]	7-1/4 [185]					
CSK12220	50		8-5/8 [220]	8-1/8 [205]					
CSK12240	50		9-1/2 [240]	8-7/8 [225]					
CSK12260	50		10-1/4 [260]	9-5/8 [245]					
CSK12280	50		11 [280]	10-3/8 [265]					
CSK12300	50		11-7/8 [300]	11-1/4 [285]					
CSK12380	50		15 [380]	14-3/8 [365]					
CSK12480	25		19 [480]	18-1/4 [465]					
CSK12600	25		23-5/8 [600]	23 [585]					



ASSY VG CYL

Cylinder-Head Self-Tapping Wood Screw

The ASSY VG CYL, with its small and easily concealed head, is ideal for wood reinforcement and concealed connections.



Cylinder Head



Fully Threaded



Drilling Tip



Certifications	ICC ESR-3178, CCMC 13677-R, ETA-11/0190
Connection Types	Wood to Wood, Concrete to Wood
Corrosion Resistance	Regular
Hardness Compliance	≤ 390 HV per CSA O86:24

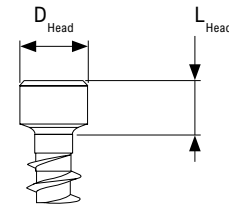
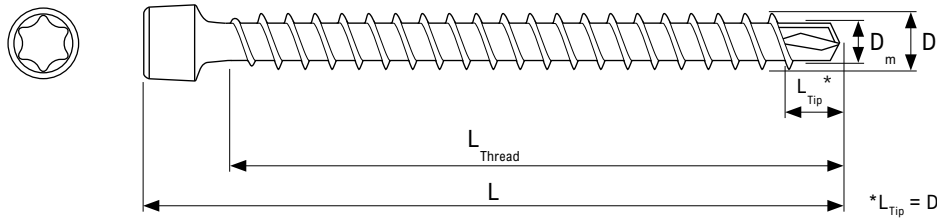

ASSY VG CYL - 5/16 in. [8 mm] DIAMETER

Specification Item #	Packaging Qty.	D	L		L _{Thread}	D _{Head}	D _m	L _{Head}	Drive Bit	
		in. [mm]	in. [mm]	[mm]	in. [mm]	in. [mm]				
CYL08120	50	5/16 [8]	4-3/4	[120]	4	0.390 [10]	0.197 [5]	0.295 [7.5]	RW 40	
CYL08140	50		5-1/2	[140]	4-7/8					[124]
CYL08160	50		6-1/4	[160]	5-5/8					[144]
CYL08180	50		7-1/8	[180]	6-1/2					[164]
CYL08200	75		7-7/8	[200]	7-1/4					[184]
CYL08220	75		8-5/8	[220]	8					[204]
CYL08240	75		9-1/2	[240]	8-7/8					[224]
CYL08260	75		10-1/4	[260]	9-5/8					[244]
CYL08280	75		11	[280]	10-3/8					[264]
CYL08300	75		11-7/8	[300]	11-1/8					[284]
CYL08330	50		13	[330]	12-3/8					[314]
CYL08360	50		14-1/4	[360]	13-1/2					[344]
CYL08380	50		15	[380]	14-3/8					[364]
CYL08430	25		17	[430]	16-1/4					[414]
CYL08480	25		19	[480]	18-1/4					[464]
CYL08530	25		20-7/8	[530]	20-1/4					[514]
CYL08580	25	22-7/8	[580]	22-1/4	[564]					

ASSY VG CYL - 3/8 in. [10 mm] DIAMETER

Specification	Packaging Qty.	D	L	L _{Thread}	D _{Head}	D _m	L _{Head}	Drive Bit
Item #		in. [mm]	in. [mm]	in. [mm]	in. [mm]			
CYL10180	50	3/8 [10]	7-1/8 [180]	6-1/2 [165]	0.528 [13.4]	0.244 [6.2]	0.315 [8]	RW 50
CYL10200	50		7-7/8 [200]	7-1/4 [185]				
CYL10220	50		8-5/8 [220]	8-1/8 [205]				
CYL10240	50		9-1/2 [240]	8-7/8 [225]				
CYL10260	50		10-1/4 [260]	9-5/8 [245]				
CYL10280	50		11 [280]	10-3/8 [265]				
CYL10300	50		11-7/8 [300]	11-1/4 [285]				
CYL10320	50		12-5/8 [320]	12 [305]				
CYL10340	50		13-3/8 [340]	12-3/4 [325]				
CYL10360	50		14-1/4 [360]	13-5/8 [345]				
CYL10380	50		15 [380]	14-3/8 [365]				
CYL10400	50		15-3/4 [400]	15-1/8 [385]				
CYL10430	25		17 [430]	16-3/8 [415]				
CYL10480	25		19 [480]	18- [456]				
CYL10530	25		20-7/8 [530]	19-7/8 [506]				
CYL10580	25		22-7/8 [580]	21-7/8 [556]				
CYL10650	25		25-5/8 [650]	24-5/8 [626]				
CYL10700	25		27-5/8 [700]	26-5/8 [676]				
CYL10750	25		29-1/2 [750]	28-5/8 [726]				
CYL10800	25		31-1/2 [800]	30-1/2 [776]				



ASSY VG RH

Reverse-Head Self-Tapping Wood Screw

The ASSY VG RH is currently the longest fully threaded fastener of its kind in the world. Performing a function similar to that of rebar in concrete, it provides a strong and reliable reinforcing solution for large mass timber projects.



Reverse Head



Fully Threaded



Drilling Tip

Certifications	ETA -11/0190
Connection Types	Large-Scale Wood Reinforcement
Corrosion Resistance	Regular
Hardness Compliance	≤ 390 HV per CSA O86:24

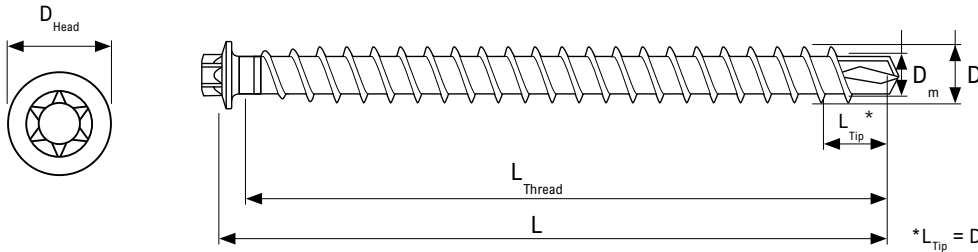

ASSY VG RH - 9/16 in. [14 mm] DIAMETER

Specification	Packaging	D	L	L _{Thread}	D _{Head}	D _m	Drive Bit
Item #	Qty.	in. [mm]	in. [mm]	in. [mm]	in. [mm]		Reverse Head Socket
RH14800	15	9/16 [14]	31-1/2 [800]	30-3/4 [780]	0.709 [18]	0.335 [8.5]	
RH14850	15		33-1/2 [850]	32-5/8 [830]			
RH14900	15		35-3/8 [900]	34-5/8 [880]			
RH14950	15		37-3/8 [950]	36-5/8 [930]			
RH141000	15		39-3/8 [1000]	38-5/8 [980]			
RH141050	15		41-3/8 [1050]	40-1/2 [1030]			
RH141100	15		43-1/4 [1100]	42-1/2 [1080]			
RH141200	15		47-1/4 [1200]	46-1/2 [1180]			
RH141300	15		51-1/8 [1300]	50-3/8 [1280]			
RH141400	15		55-1/8 [1400]	54-3/8 [1380]			
RH141500	15		59 [1500]	58-1/4 [1480]			

Note:

- The ASSY VG RH is installed using a reverse-head socket. Details about this socket are provided in the Accessories section.



Ritchie Market

Edmonton, Alberta

Factored and Specified Resistance Values

Factored fastener resistances are permitted to be determined through the equations presented in CSA O86:24 Section 12.12 or through approved testing. In this guide, the factored withdrawal resistance values are derived directly from CCMC 13677-R. Specified head pull-through resistance, tensile resistance, shear and buckling resistance values are presented in accordance with tested values and should be input into appropriate CSA equations for factored resistance. Refer to the footnotes within each design table and the Connection Classification section (Page 15) for further information.

3.1 - Factored Withdrawal Resistance, $P_{rw,\alpha}$, per mm Thread Penetration Length for Fully Threaded Fastener Series

Diameter in. [mm]	$P_{rw,\alpha}$ [N/mm]						
	Relative Density, G						
	Lumber & Glulam						PSL
	G = 0.35	G = 0.42	G = 0.44	G = 0.47	G = 0.49	G = 0.55	ESG ≥ 0.50
5/16 [8]	42	61	65	74	80	101	47
3/8 [10]	53	76	81	92	100	126	59
1/2 [12]	63	91	97	110	120	151	70
9/16 [14]	74	107	113	129	140	176	82

Notes:

- The factored resistance values in this table are derived from the equation presented in CCMC 13677-R (Eq. 1 on Page 15) and must be multiplied by the effective thread penetration length, l_{ef} , in mm to obtain the total factored withdrawal resistance for the fastener.
- Tests conducted in general accordance with ICC-ES AC233 have validated that factored withdrawal resistance values are equivalent to or better than tabulated results derived from the CCMC 13677-R equation for 14 mm.
- The factored resistance values apply to fasteners installed perpendicular to the grain of the wood member. For fasteners installed at an angle to the wood grain, α , values must be divided by the denominator of Eq. 1 on Page 15.
- The factored resistance values presented in this table are calculated using $K_D = 1.0$ and $K_{SF} = 1.0$. For all other load duration and service conditions, values must be multiplied by appropriate K_D and/or K_{SF} specified in CSA O86:24 Clause 12.2.1.7.
- G refers to the relative density assigned to the wood species. ESG must be the equivalent specific gravity given in the product specifications of PSL.
- Connection design must meet all relevant requirements outlined in the General Notes to the Designer section.

3.2 - Specified Head Pull-Through Resistance, f_{pt} , for Fully Threaded Fastener Series

Diameter in. [mm]	Fastener Type	f_{pt} [kN]				
		Relative Density, G				
		Lumber & Glulam				PSL
		G = 0.35	G = 0.42	G = 0.49	G = 0.55	ESG ≥ 0.50
5/16 [8]	VG CSK	2.76	3.59	4.47	5.29	5.08
3/8 [10]		3.40	4.27	5.21	6.05	6.27
1/2 [12]		3.40	4.27	5.21	6.05	6.27

Notes:

- The specified head pull-through values presented in this table are the 5th percentile test value with a confidence interval of 75% in accordance with CSA O86:24 Clause 17.6.2.5.
- Minimum wood member thicknesses are specified in Note 16 in the General Notes to the Designer section (Page 10).
- Connection design must meet all relevant requirements outline in the General Notes to the Designer section.
- G refers to the relative density assigned to the wood species. ESG must be the equivalent specific gravity given in the product specifications of PSL. For G=0.44 and G=0.47, values for G=0.42 may be used.
- The specified head pull-through resistance values, f_{pt} , are applicable to screws installed perpendicular to the faces of the wood members and must be multiplied by all modification factors included in CSA O86:24 Clause 12.2.1.7.
- The factored head pull-through resistance should be calculated per CSA O86:24 Clause 12.12.8.3.

3.3 - Specified Buckling Resistance Values, P_s , for Fully Threaded Fastener Series

Diameter in. [mm]	P_s [kN]
5/16 [8]	36.40
3/8 [10]	56.60

Notes:

- The specified buckling resistance values presented in this table are the 5th percentile test value with a confidence interval of 75% in accordance with CSA O86:24 Clause 17.6.3.
- The specified buckling resistance values presented in this table are valid for screws installed perpendicular to grain only ($\alpha = 90^\circ$). For fasteners installed at other angles to the wood grain, values should be derived per CSA O86:24 Clause 12.12.9.2.3. The specified buckling resistance values provided must be multiplied by the modification factor for screw buckling, K_{CS} , $K_{CS} = 0.7$ for fasteners installed perpendicular to grain.
- Testing was conducted in glulam specimens of Douglas Fir, Black Spruce, and SYP.
- The values in the table above are applicable for fully threaded ASSY VG screws with diameters of 5/16 in. [8 mm] and 3/8 in. [10 mm] in all lengths.
- The factored buckling resistance should be calculated per CSA O86:24 Clause 12.12.9.2.

3.4 - Specified Strength and Resistance Values for Fully Threaded Fastener Series

Diameter in. [mm]	Specified Yield Strength f_y [MPa]	Specified Tensile Resistance t_s [kN]	Specified Shear Resistance v_s [kN]	Allowable Insertion Torque [N · m]
5/16 [8]	1,034	18.85	11.51	16.67
3/8 [10]	1,103	28.37	19.11	30.00
1/2 [12]	1,146	40.96	21.15	50.00
9/16 [14]	1,250	52.52	33.73	76.67

Notes:

- Connection design must meet all relevant requirements outlined in the General Notes to the Designer section.
- The specified yield strength values presented in this table are per ICC ESR-3178 2023.
- The allowable insertion torque is determined in accordance with EAD 130118-01-0603, where the ratio of the torsional strength to the insertion torque should be at least 1.5.
- The specified tensile and shear resistance values presented in this table are the 5th percentile test value with a confidence interval of 75% in accordance with CSA O86:24 Clauses 17.6.2.2 and 17.6.2.3.
- The factored tensile resistance shall be calculated in accordance with CSA O86:24. Clause 12.12.8.4.
- The factored shear resistance shall be calculated in accordance with CSA O86:24 Clause 12.12.10.6.

Geometry Requirements

Glulam & Timber

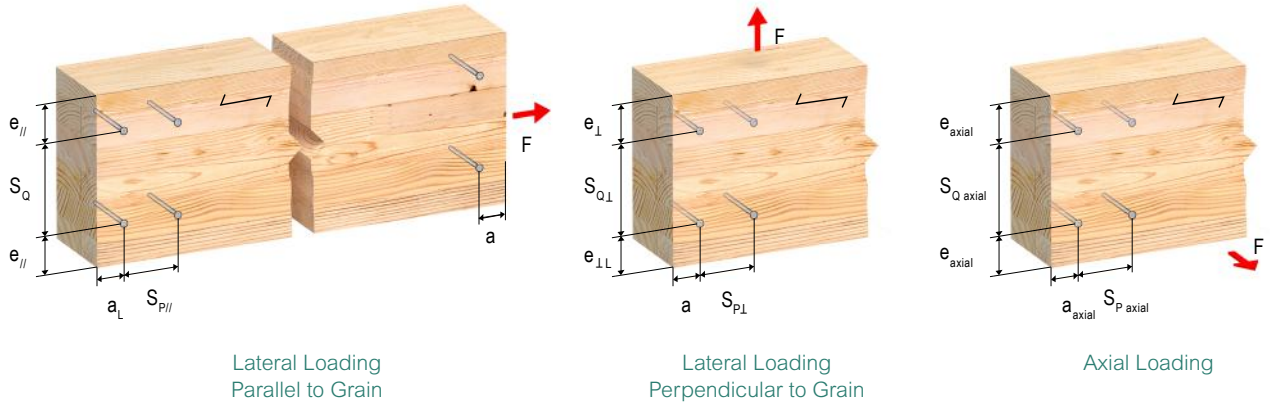

3.5 - Geometry Requirements for Fully Threaded Self-Tapping Screws in Glulam and Timber

Loading Configuration		Installation Configuration	
		Glulam & Timber	
		Any G	
End Distance	Lateral loading parallel to grain in tension	a_L	12D
	Lateral loading parallel to grain in compression	a	7D
	Lateral loading perpendicular to grain	a	7D
	Axial loading	a_{axial}	10D
Edge Distance	Lateral loading parallel to grain	$e_{ }$	3D
	Lateral loading perp. to grain, towards edge	$e_{\perp L}$	7D
	Lateral loading perp. to grain, away from edge	e_{\perp}	3D
	Axial loading	e_{axial}	4D
Spacing Between Fasteners in a Row [parallel to grain]	Lateral loading parallel to grain	$S_{P }$	5D
	Lateral loading perpendicular to grain	$S_{P\perp}$	5D
	Axial loading	$S_{P\ axial}$	7D
Spacing Between Rows [perpendicular to grain]	Lateral loading parallel to grain	S_Q	4D
	Lateral loading perpendicular to grain	$S_{Q\perp}$	4D
	Axial loading	$S_{Q\ axial}$	5D

Notes:

- All connection design must meet all the relevant requirements outlined in the General Notes to the Designer section.
- For species prone to splitting (e.g., Douglas Fir, Hem-Fir, and Western Red Cedar), it is recommended that the parallel-to-grain spacing requirements be increased by 50%.
- Within a row, fasteners may be staggered up to 2D to further reduce the potential for splitting.
- The geometry requirements are in accordance with ICC-ESR-3178 (2023), as accepted in CSA O86:24 Clause 12.12.5 provisions.
- The minimum geometry requirements outlined in this table are meant to provide sufficient end and edge distances, as well as spacings between rows and between fasteners in a row, to reduce the potential for splitting.
- Applying the minimum requirements does not prevent wood failure such as row tear-out, group tear-out, block tear-out, net tension failure, or splitting perpendicular to grain.

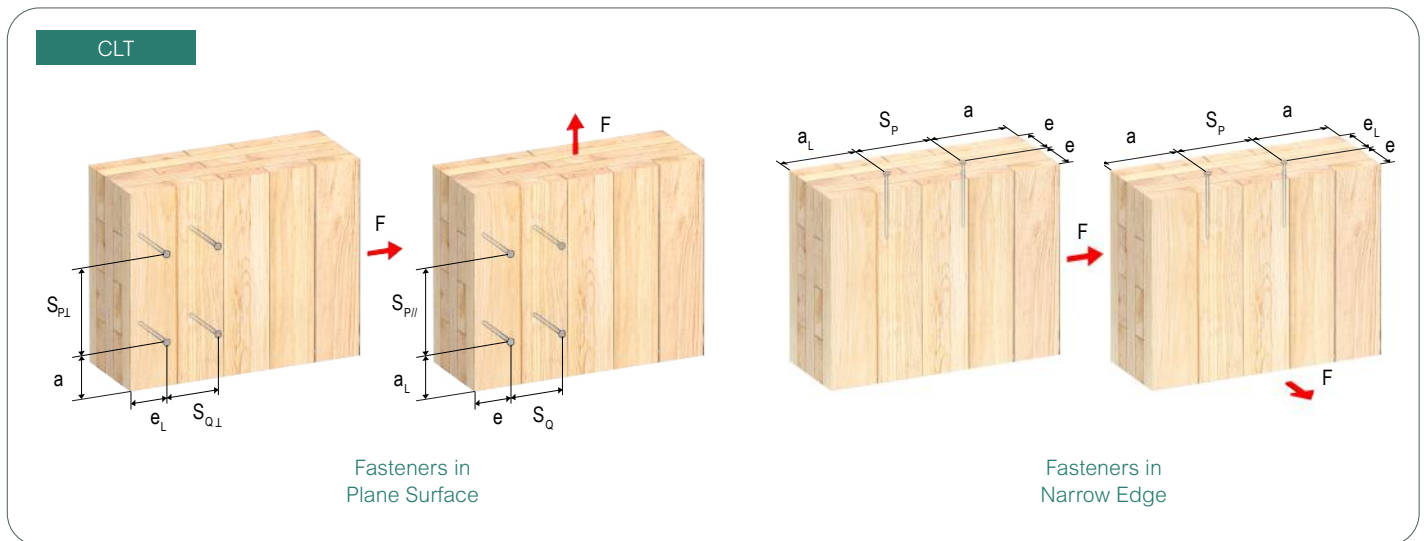

3.6 - Geometry Requirements for Fully Threaded Self-Tapping Screws in CLT

Loading Configuration		Installation Configuration CLT [$G = 0.42$]	
		Surface	Edge
End Distance	Lateral loading parallel to grain in tension	a_L	6D
	Lateral loading parallel to grain in compression	a	6D
	Lateral loading perpendicular to grain	a	7D
	Axial loading	a_{axial}	7D
Edge Distance	Lateral loading parallel to grain	$e_{//}$	2.5D
	Lateral loading perp. to grain, towards edge	$e_{\perp L}$	6D
	Lateral loading perp. to grain, away from edge	e_{\perp}	2.5D
	Axial loading	e_{axial}	3D
Spacing Between Fasteners in a Row [parallel to grain]	Lateral loading parallel to grain	$S_{P//}$	4D
	Lateral loading perpendicular to grain	$S_{P\perp}$	10D
	Axial loading	$S_{P axial}$	10D
Spacing Between Rows [perpendicular to grain]	Lateral loading parallel to grain	S_Q	2.5D
	Axial loading ($D > 8\text{mm}$)	$S_{Q axial}$	4D

Notes:

- All connection design must meet all the relevant requirements outlined in the General Notes to the Designer section.
- For species prone to splitting (e.g., Douglas Fir and Hem-Fir), it is recommended that the parallel-to-grain spacing requirements be increased by 50%.
- Within a row, fasteners may be staggered up to 2D to further reduce the potential for splitting.
- The listed values are applicable when the CLT panel thickness is at least 10D.
- The minimum penetration length of the screw into the narrow face of the panel shall be 10D.
- The values for axially loaded fasteners are per CSA O86:24 Clause 12.12.5. All other values derived in accordance with ETA-11/0190.
- The minimum geometry requirements outlined in this table are meant to provide sufficient end and edge distances, as well as spacings between fasteners, to reduce the potential for splitting.
- Applying the minimum requirements does not prevent wood failure, such as row tear-out, group tear-out, block tear-out, net tension failure, or splitting perpendicular to grain.



Bow River Pedestrian Bridge

Banff, Alberta

Stainless Steel Fastener Series

MTC Solutions stainless steel self-tapping Partially Threaded fasteners are versatile screws used for connections in wet service conditions. For more information, read the Service Condition & Corrosion section.



∅ · 1/4 in. [6 mm]
 · 5/16 in. [8 mm]

ℓ · 2-3/8 in. to 11-7/8 in. [60 mm to 300 mm]

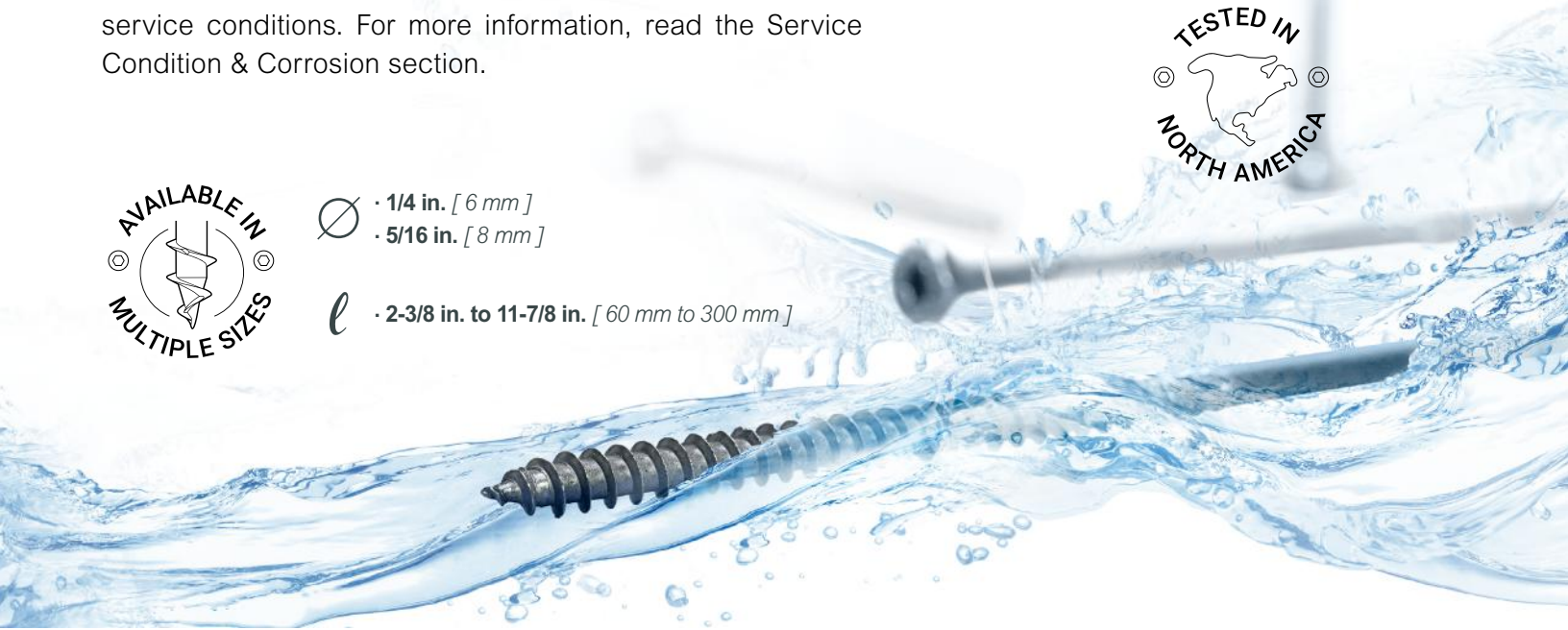

Engineered Heads



Countersunk Head



Washer Head



Ring Threaded Tip

Reduces the need for predrilling and provides the quickest fastener wood bite



Stainless Steel

Stainless steel fasteners for use in wet service conditions



Large Threads

Provides high withdrawal resistance

CERTIFICATIONS



ICC
EVALUATION
SERVICE

ICC-ESR-3179

ISO 50001

Energy
Management
System



ETA-11/0190

Product Overview

ASSY A2 Ecofast

Countersunk-Head Self-Tapping Wood Screw

The ASSY A2 Ecofast stainless steel fasteners are ideal for exterior projects, delivering a clean and flush architectural finish. Applications include outdoor fencing, rails, solar panels, cladding, fascia board, strapping, and decking.



Countersunk Head with Milling Pockets



Ring Thread Tip



Suitable in Wet Service Conditions



Certifications	ICC-ESR-3179, ETA-11/0190
Connection Types	Wood to Wood, Steel to Wood
Corrosion Resistance	High

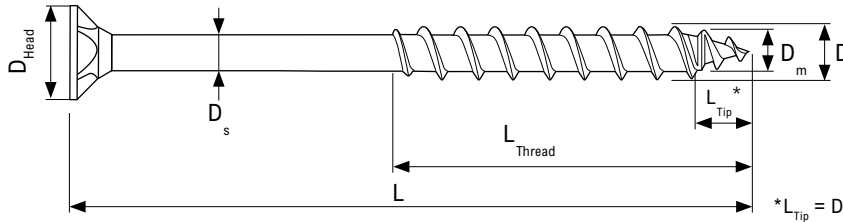

ASSY A2 Ecofast - 1/4 in. [6 mm] & 5/16 in. [8 mm] DIAMETERS

Specification Item #	Packaging Qty.	D	L	L _{Thread}	D _{Head}	D _m	D _s	Drive Bit
		in. [mm]	in. [mm]	in. [mm]	in. [mm]			
A2ECO0660	200	1/4 [6]	2-3/8 [60]	1-1/2 [37]	0.472 [12]	0.154 [3.9]	0.173 [4.4]	RW 30
A2ECO0680	100		3-1/8 [80]	2 [50]				
A2ECO06100	100		4 [100]	2-3/8 [60]				
A2ECO06120	100		4-3/4 [120]	2-3/4 [70]				
A2ECO06140	100		5-1/2 [140]	2-3/4 [70]				
A2ECO0880	75	5/16 [8]	3-1/8 [80]	2 [50]	0.591 [15]	0.197 [5]	0.234 [5.95]	RW 40
A2ECO08100	75		4 [100]	2-3/8 [60]				
A2ECO08120	75		4-3/4 [120]	3-1/8 [80]				
A2ECO08140	75		5-1/2 [140]	3-1/8 [80]				
A2ECO08160	75		6-1/4 [160]	3-1/8 [80]				
A2ECO08180	75		7-1/8 [180]	3-1/8 [80]				
A2ECO08200	75		7-7/8 [200]	3-1/8 [80]				
A2ECO08220	75		8-5/8 [220]	4 [100]				
A2ECO08240	75		9-1/2 [240]	4 [100]				
A2ECO08260	75		10-1/4 [260]	4 [100]				
A2ECO08280	75		11 [280]	4 [100]				
A2ECO08300	75	11-7/8 [300]	4 [100]					

ASSY A2 SK

Washer-Head Self-Tapping Wood Screw

The ASSY A2 SK stainless steel fasteners are ideal for exterior wood-to-wood applications requiring a high head pull-through capacity. Applications include exposed timber frame structures, carpentry, and boardwalks.



Washer Head



Ring Thread Tip



Suitable in Wet Service Conditions

Certifications	ICC-ESR-3179, ETA-11/0190
Connection Types	Wood to Wood
Corrosion Resistance	High

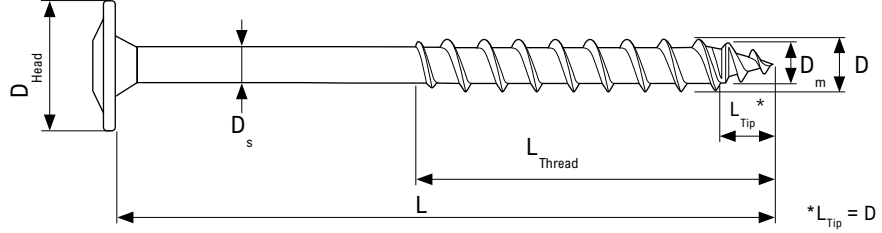

ASSY A2 SK - 1/4 in. [6 mm] & 5/16 in. [8 mm] DIAMETERS

Specification	Packaging Qty.	D	L	L _{Thread}	D _{Head}	D _m	D _s	Drive Bit
Item #		in. [mm]	in. [mm]	in. [mm]	in. [mm]			
A2SK0680	100	1/4 [6]	3-1/8 [80]	2 [50]	0.551 [14]	0.154 [3.9]	0.173 [4.4]	RW 30
A2SK06100	100		4 [100]	2-3/8 [60]				
A2SK06120	100		4-3/4 [120]	2-3/4 [70]				
A2SK06140	100		5-1/2 [140]	2-3/4 [70]				
A2SK08100	50	5/16 [8]	4 [100]	2-3/8 [60]	0.739 [18.9]	0.197 [5]	0.234 [5.95]	RW 40
A2SK08120	50		4-3/4 [120]	3-1/8 [80]				
A2SK08140	50		5-1/2 [140]	3-1/8 [80]				
A2SK08160	50		6-1/4 [160]	3-1/8 [80]				
A2SK08180	50		7-1/8 [180]	3-1/8 [80]				
A2SK08260	50		10-1/4 [260]	4 [100]				
A2SK08300	50		11-7/8 [300]	4 [100]				

Specified Resistance Values

4.1 - Factored Withdrawal Resistance, $P_{rw,\alpha}$, per mm Thread Penetration Length for Stainless Steel Fastener Series

Diameter in. [mm]	$P_{rw,\alpha}$ [N/mm]			
	Relative Density, G			
	G = 0.42	G = 0.44	G = 0.47	G = 0.49
1/4 [6]	46	48	55	60
5/16 [8]	61	65	74	80

- Notes:
- The factored resistance values in this table are derived from the equation presented in CCMC 13677-R (Eq. 1 on Page 15) and must be multiplied by the effective thread penetration length, l_{eff} , in mm to obtain the total factored withdrawal resistance for the fastener.
 - The factored resistance values apply to fasteners installed perpendicular to the grain of the wood member. For fasteners installed at an angle to the wood grain, α , values must be divided by the denominator of Eq. 1 on Page 15.
 - The factored resistance values presented in this table are calculated using $K_D = 1.0$ and $K_{SF} = 1.0$. For all other load duration and service conditions, values must be multiplied by appropriate K_D and/or K_{SF} specified in CSA O86:24 Clause 12.2.1.7.
 - G refers to the relative density assigned to the wood species. ESG must be the equivalent specific gravity given in the product specifications of PSL.
 - Connection design must meet all relevant requirements outlined in the General Notes to the Designer section.

4.2 - Specified Head Pull-Through Resistance, f_{pt} , for Stainless Steel Fastener Series

Diameter in. [mm]	Fastener Type	f_{pt} [kN]				
		Relative Density, G				
		Lumber & Glulam				PSL
		G = 0.35	G = 0.42	G = 0.49	G = 0.55	ESG \geq 0.50
1/4 [6]	A2 Ecofast	1.70	2.08	2.48	2.82	3.35
	A2 SK	3.12	3.82	4.55	5.20	5.62
5/16 [8]	A2 Ecofast	2.39	2.96	3.54	4.06	4.18
	A2 SK	—	5.55	6.54	—	—

- Notes:
- The specified head pull-through values presented in this table are the 5th percentile test value with a confidence interval of 75% in accordance with CSA O86:24 Clause 17.6.2.5.
 - Minimum wood member thicknesses are specified in Note 16 in the General Notes to the Designer section (Page 10).
 - Connection design must meet all relevant requirements outline in the General Notes to the Designer section.
 - G refers to the relative density of the wood species. ESG is the equivalent specific gravity given in the product specifications of PSL. For G=0.44 and G=0.47, values for G=0.42 may be used.
 - The specified head pull-through resistance values, f_{pt} , are applicable to screws installed perpendicular to the faces of the wood members and must be multiplied by all modification factors included in CSA O86:24 Clause 12.2.1.7.
 - The factored head pull-through resistance should be calculated per CSA O86:24 Clause 12.12.8.3.

4.3 - Specified Strength and Resistance Values for Stainless Steel Fastener Series

Diameter in. [mm]	Bending Yield Strength f_y [MPa]	Specified Tensile Resistance t_s [kN]	Specified Shear Resistance v_s [kN]	Allowable Insertion Torque [N · m]
1/4 [6]	766	6.43	2.41	4.27
5/16 [8]	762	12.52	4.90	10.67

- Notes:
- Connection design must meet all relevant requirements outlined in the General Notes to the Designer section.
 - The specified yield strength values presented in this table are the mean test value using the minor diameter of the fastener in accordance with CSA O86:24 Clause 17.6.2.1.
 - The allowable insertion torque is determined in accordance with EAD 130118-01-0603, where the ratio of the torsional strength to the insertion torque should be at least 1.5.
 - The specified tensile and shear resistance values presented in this table are the 5th percentile test value with a confidence interval of 75% in accordance with CSA O86:24 Clauses 17.6.2.2 and 17.6.2.3.
 - The factored tensile resistance shall be calculated in accordance with CSA O86:24 Clause 12.12.8.4.6. The factored shear resistance shall be calculated in accordance with CSA O86:24 Clause 12.12.10.6.

Note that the service condition factors, K_{SF} , for stainless steel self-tapping screws can be taken as equivalent to those of lag screws given in CSA O86:24 Table 12.1.

Geometry Requirements

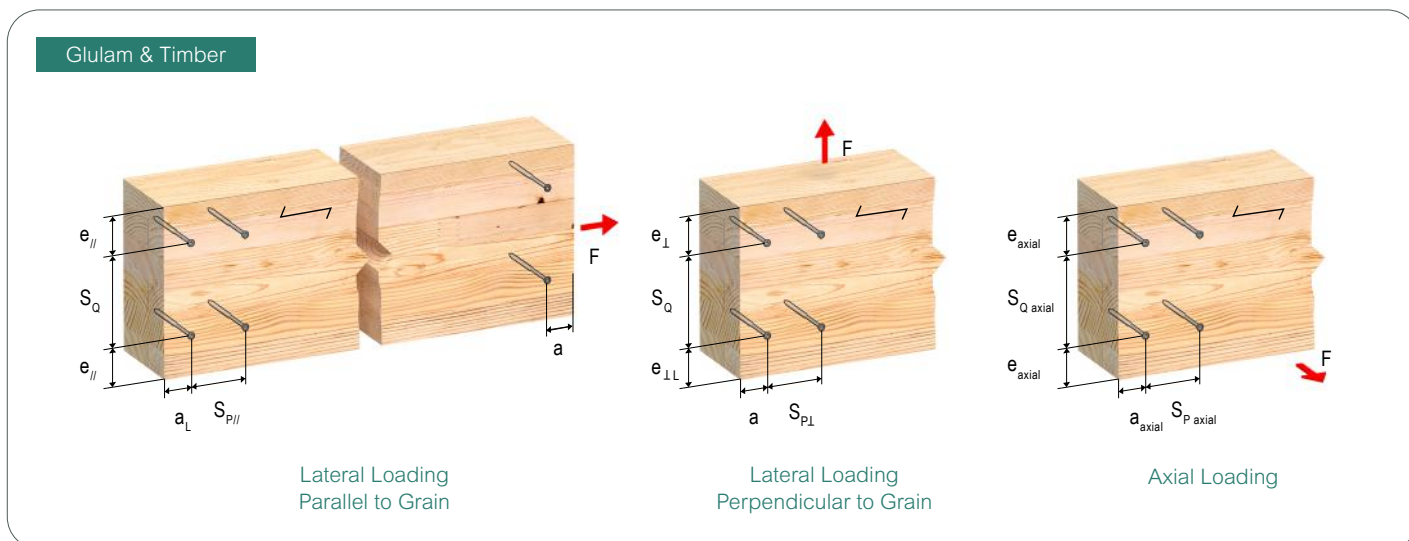

4.4 - Geometry Requirements for Stainless Steel Self-Tapping Screws in Glulam and Timber

Loading Configuration		Installation Configuration			
		Glulam & Timber			
		Self-Tapping Screws		Predrilled	
		$G \leq 0.44$	$0.44 < G \leq 0.5$	Any G	
End Distance	Lateral loading parallel to grain in tension	a_L	15D**	22D	12D*
	Lateral loading parallel to grain in compression	a	10D**	15D	7D*
	Lateral loading perpendicular to grain	a	10D**	15D	7D*
	Axial loading	a_{axial}	10D*	10D*	10D*
Edge Distance	Lateral loading parallel to grain	$e_{ }$	5D	7D	3D
	Lateral loading perp. to grain, towards edge	$e_{\perp L}$	10D	12D	7D
	Lateral loading perp. to grain, away from edge	e_{\perp}	5D	7D	3D
	Axial loading	e_{axial}	4D	4D	4D
Spacing Between Fasteners in a Row [parallel to grain]	Lateral loading parallel to grain	$S_{P }$	12D**	18D	5D*
	Lateral loading perpendicular to grain	$S_{P\perp}$	12D**	18D	5D*
	Axial loading	$S_{P\ axial}$	7D*	7D*	7D*
Spacing Between Rows [perpendicular to grain]	Lateral loading parallel to grain	S_Q	5D	7D	4D
	Lateral loading; staggered rows	S_{Qs}	2.5D	2.5D	—
	Axial loading	$S_{Q\ axial}$	5D	5D	5D

* For Douglas Fir-Larch and Western Red Cedar, this minimum spacing shall be increased by 50%

** For Western Red Cedar, this minimum spacing shall be increased by 50%

Notes:

- All connection design must meet all the relevant requirements outlined in the General Notes to the Designer section.
- Values for spacing between staggered rows apply where fasteners in adjacent rows are offset by half of the spacing between fasteners in a row.
- Within a row, fasteners may be staggered up to 2D to further reduce the potential for splitting.
- The geometry requirements for staggered rows are per ESR 3179. All remaining geometry requirements are per CSA O86:24 Clause 12.12.5.
- The minimum geometry requirements outlined in this section are meant to provide sufficient end and edge distances, as well as spacings between rows and between fasteners in a row, to reduce the potential for splitting.
- Applying the minimum requirements does not prevent wood failure, such as row tear-out, group tear-out, block tear-out, net tension failure, or splitting perpendicular to grain.



North Surrey Sport & Ice Complex

Surrey, British Columbia

Self-Drilling Dowels

MTC Solutions Self-Drilling Dowels are cylinder-head dowel fasteners designed for timber connections with knife plates. It can be used in various connection scenarios such as timber moment connections, custom beam hangers, and hold-down connections, where internal steel plates are used for shear load transmission.



∅ · 0.27 in. [6.9 mm]

ℓ · 2-7/8 in. to 9-1/8 in. [73 mm to 233 mm]

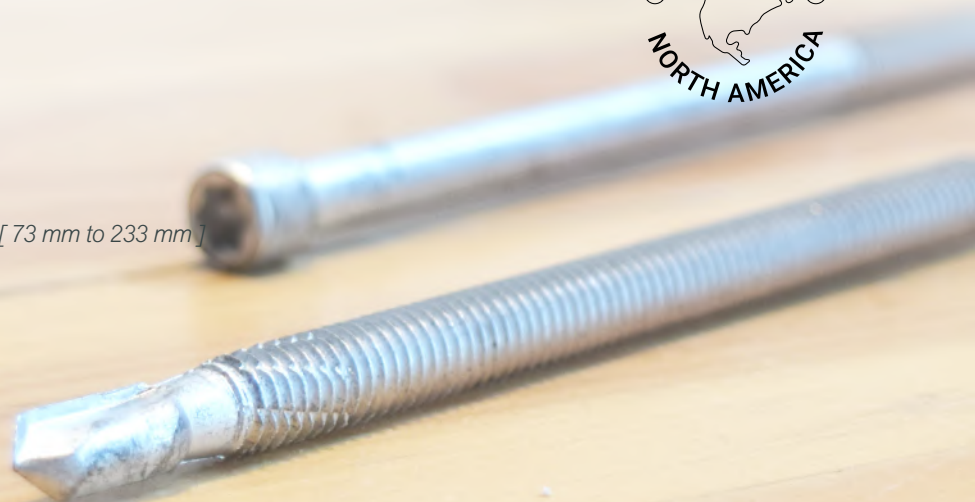

Engineered Head



Cylinder Head



Case-Hardened Steel

A ductile core with increased outer surface hardness, providing high bending yield strength & ductility



Coated Steel

Fasteners with a high-grade zinc–aluminum flake coating for use in dry service conditions



Continuous Thread

Helps prevent the dowel from slipping out of the knife plate, especially when loaded cyclically



Drilling Tip

Drilling tip reduces the need for predrilling in wood and thin metal plates. Predrilling is recommended for thicker (> 1/8 in.) knife plates and connections with multiple knife plates

Product Overview

Self-Drilling Dowel

Cylinder-Head Fastener for Internal Knife Plate Connections

The Self-Drilling Dowel (SDD) is engineered to be used in multiple connection scenarios where internal steel plates are used for load transmission. The dowel head is perfect for concealed connections, and the continuous threads keep the fastener secured in the metal plate. The SDD is suitable for use in dry service conditions only.



Cylinder Head



Continuous Thread



Drilling Tip

Connection Types	Internal Steel Plate to Wood
Corrosion Resistance	Regular

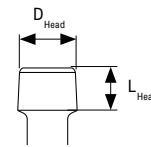
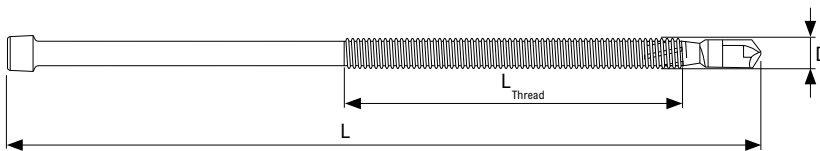

Self-Drilling Dowel - 0.27 in. [6.9 mm] DIAMETER

Specification	Packaging	D	L	L _{Thread}	D _{Head}	L _{Head}	Drive Bit
Item #	Qty.	in. [mm]	in. [mm]	in. [mm]	in. [mm]	in. [mm]	
SDD0673	50	0.27 [6.9]	2-7/8 [73]	1-1/4 [31]	0.394 [10]	0.295 [7.5]	RW 40
SDD0693	50		3-5/8 [93]	1-5/8 [40]			
SDD06113	50		4-1/2 [113]	2 [50]			
SDD06133	50		5-1/4 [133]	2-3/8 [60]			
SDD06153	50		6 [153]	2-3/4 [70]			
SDD06173	50		6-3/4 [173]	3-1/8 [80]			
SDD06193	50		7-5/8 [193]	3-1/2 [90]			
SDD06213	50		8-3/8 [213]	3-7/8 [100]			
SDD06233	50		9-1/8 [233]	4-3/8 [110]			

Specified Strength Values

5.1 - Specified Strength Values for Self-Drilling Dowels

Diameter in. [mm]	Bending Yield Strength f _y [MPa]	Specified Shear Resistance v _s [kN]	Allowable Insertion Torque [N · m]
0.27 [6.9]	870	11.52	38.8

Notes:

1. Connection design must meet all relevant requirements outlined in the General Notes to the Designer section.
2. The allowable insertion torque is determined in accordance with EAD 130118-01-0603, where the ratio of the torsional strength to the insertion torque should be at least 1.5.

Geometry Requirements

Glulam & Timber

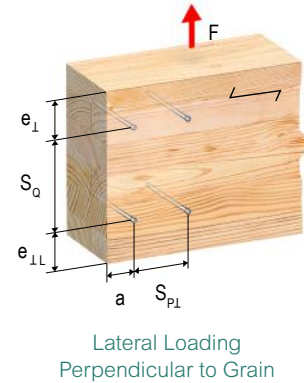
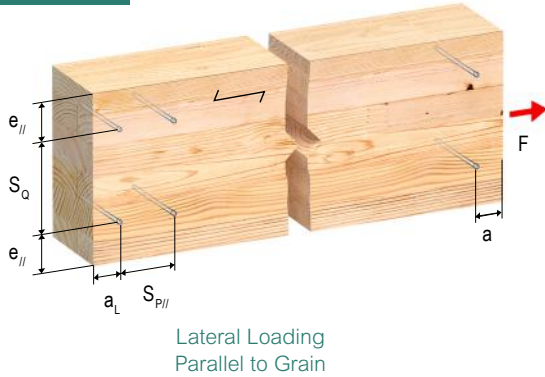

CLT

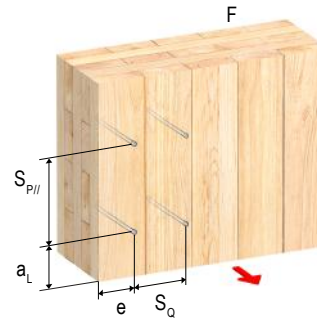
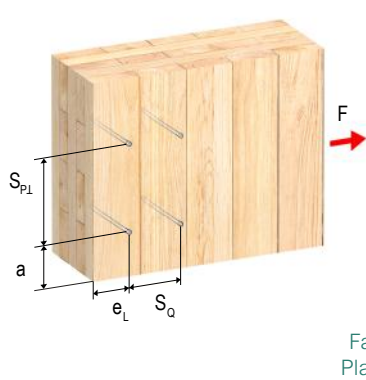

5.2 - Geometry Requirements for Self-Drilling Dowels

Loading Configuration			Installation Configuration
			Glulam, Timber, & CLT Face [Any G]
End Distance	Lateral loading parallel to grain in tension	a_L	5D*
	Lateral loading parallel to grain in compression	a	4D*
	Lateral loading perpendicular to grain	a	4D*
Edge Distance	Lateral loading parallel to grain	$e_{ }$	1.5D**
	Lateral loading perp. to grain, towards edge	$e_{\perp L}$	4D
	Lateral loading perp. to grain, away from edge	e_{\perp}	1.5D
Spacing Between Fasteners in a Row [parallel to grain]	Lateral loading parallel to grain	$S_{P }$	4D
	Lateral loading perpendicular to grain	$S_{P\perp}$	3D
Spacing Between Rows [perpendicular to grain]	Lateral loading parallel to grain	S_Q	3D
	Lateral loading perpendicular to grain	$S_{Q\perp}$	3D

* Minimum required spacing is 2 in. [50 mm].

** Minimum required spacing is $1/2 S_{Q||}$.

Notes:

- All connection design must meet all the relevant requirements outlined in the General Notes to the Designer section.
- In wood species sensitive to splitting, it may be necessary to increase the minimum geometry requirements.
- The listed values are applicable when the CLT panel thickness is at least 10D.
- The geometry requirements for cases involving predrilling are as per CSA O86:24 Clauses 12.4.3.1, 12.4.3.2, and 12.4.3.3.
- The minimum geometry requirements outlined in this section are meant to provide sufficient end and edge distances, as well as spacings between rows and between fasteners in a row, to reduce the potential for splitting.
- Applying the minimum requirements does not prevent wood failure such as row tear-out, group tear-out, block tear-out, net tension failure, or splitting perpendicular to grain.



Wood Innovation and Design Centre

Prince George, British Columbia

Accessories

90° Cup Washer

Cost-Reducing Solution for Steel-to-Wood Connections

The 90° Cup Washer is a machined steel part designed for use with countersunk-head screws ASSY Ecofast and ASSY VG CSK. The washer provides proper bearing for the screw head in steel-to-wood connections, eliminating the need for reaming out the steel plate.



Designed For Countersunk-Head Fasteners

Connection Types Steel to Wood



Countersunk Head

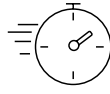

Fast Installation

1/4 in., 5/16 in., and 3/8 in. Cup Washer Dimensions

Nominal Fastener Diameter [D]	d_1	OD	h	al	d_2	d_3
in. [mm]				°	in. [mm]	
1/4 [6]	0.252 [6.4]	0.866 [22]	0.177 [4.5]	45	0.551 [14]	0.591 [15]
5/16 [8]	0.331 [8.4]	0.984 [25]	0.197 [5]	41	0.669 [17]	0.709 [18]
3/8 [10]	0.409 [10.4]	1.181 [30]	0.276 [7]	37	0.787 [20]	0.827 [21]

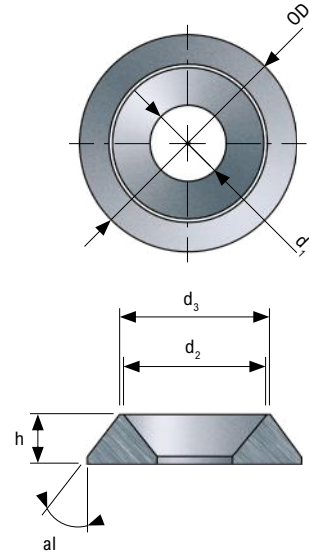

Note:

- The dimensions of the steel plate holes are provided in Appendix C: Steel Plate Detailing (Page 76).

1/2 in. Cup Washer Dimensions

Nominal Fastener Diameter [D]	d_1	OD	h	t_{wf}	d_2	h_p
in. [mm]						
1/2 [12]	0.492 [12.5]	1.654 [42]	0.197 [5]	0.157 [4]	0.906 [23]	0.118 [3]

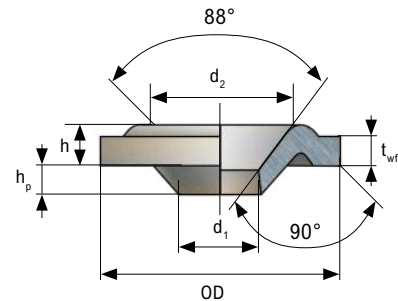

Note:

- The diameter of the steel plate holes should be equal to D_s .

45° Wedge Washer

Cost-Reducing Solution for Steel-to-Wood Connections

The 45° Wedge Washer when paired with a predrilling jig, offers a cost-reducing solution for steel-to-wood connections using ASSY Ecofast and ASSY VG CSK fasteners. The wedge washer is inserted into a simple punched or machined slotted hole. Its use eliminates the need for predrilled inclined countersunk holes in steel plates and only requires standard slotted holes, resulting in cost reductions.



Designed For	Countersunk-Head Fasteners
Connection Types	Steel to Wood

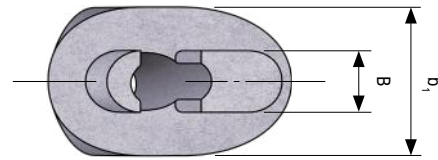
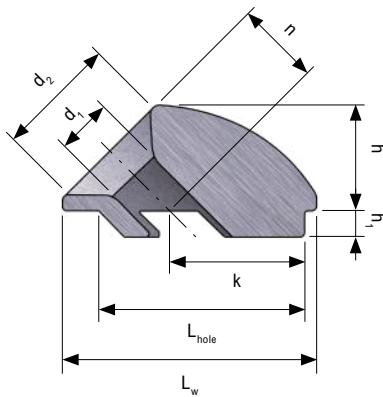
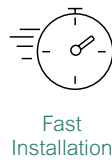

45° Washer Dimensions

Nominal Fastener Diameter [D]	d ₁	d ₂	L _w	b ₁	h	h ₁	B	L _{hole}	k	n	Steel Plate Thickness	
											Min.	Max.
in.												
[mm]												
5/16 [8]	0.335 [8.5]	0.748 [19]	1.535 [39]	0.945 [24]	0.63 [16]	0.142 [3.6]	0.39 [9.9]	1.248 [31.7]	0.827 [21]	0.5 [12.7]	0.157 [4]	0.591 [15]
3/8 [10]	0.421 [10.7]	0.945 [24]	2.047 [52]	1.142 [29]	0.843 [21.4]	0.185 [4.7]	0.425 [10.8]	1.72 [43.7]	1.13 [28.7]	0.724 [18.4]	0.197 [5]	0.787 [20]
1/2 [12]	0.5 [12.7]	1.024 [26]	2.323 [59]	1.181 [30]	0.925 [23.5]	0.22 [5.6]	0.504 [12.8]	1.957 [49.7]	1.339 [34]	0.78 [19.8]	0.236 [6]	0.984 [25]

Note:

- For coated steel plates, the hole needs to be oversized in order to account for the thickness of the coating. Test fitting of wedge washers into steel plate holes is required to ensure that the required tolerances are met.

45° Washer Steel Plate Hole Dimensions

Nominal Fastener Diameter [D]	B		L _{hole}	
	Min.	Max.	Min.	Max.
in.				
[mm]				
5/16 [8]	0.394 [10]	0.433 [11]	1.260 [32]	1.299 [33]
3/8 [10]	0.441 [11]	0.472 [12]	1.732 [44]	1.772 [45]
1/2 [12]	0.512 [13]	0.551 [14]	1.969 [50]	2.008 [51]

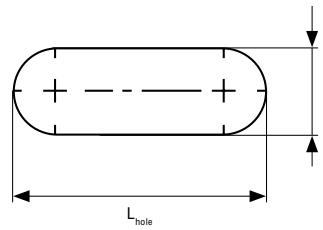

Predrilling Jig

Eases Predrilling for Inclined Fasteners

The Predrilling Jig ensures precise alignment for fasteners in steel-to-wood connections, especially where the head is countersunk into a steel plate or washer, minimizing the risk of off-center and off-axis installation. By guiding the drill bit to create accurate pilot holes, it guarantees optimal fastener seating and helps to ensure the overall strength of the connection. The inner diameters (d) accommodate standard imperial and metric drill bit diameters recommended for predrilling and are available in three sizes:

- **3/16 in.** [5 mm]
- **1/4 in.** [6 mm]
- **9/32 in.** [7 mm]

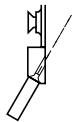

RICON XL
Compatible



MEGANT
Compatible

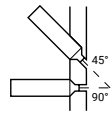

45° & 90° Steel Plate
Compatible

Bits

Patented Bits for ASSY Fasteners

The ASSY RW bit is a hardened bit designed for quick and efficient installation of ASSY fasteners. Suitable bits for each fastener are listed in its specification table.



Snug
Fit



Reduced
Wobbling



Optimum Torque
Transfer



RW 30



RW 40



RW 50

Magnetic Hex Socket

Accessory for Installing ASSY Kombi Screws

The magnetic socket can be used for faster installation of the ASSY Kombi screws. The built-in magnet makes it easy to place and hold the screw head inside the socket before installation. The magnetic socket is suitable for use with most low-RPM high-torque drills that are used in the installation of ASSY self-tapping screws.



Hex Head

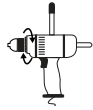

Suitable for Double Handle Drill



Optimum Torque Transfer

Bit Holder Socket

Bit Holder Socket for RW 50 Bits

The Bit Holder Socket is designed to hold the RW 50 bits on large double handle drills. The socket can be used with the magnetic bit holder case to facilitate the installation of larger-diameter screws, which requires higher torque. The Bit Holder Socket is meant to be used with the Magnetic Bit Case Holder SK, VG CSK.

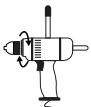

Suitable for Large Drills



RW 50 Compatible



Optimum Torque Transfer

Reverse-Head Socket

Accessory for Installing ASSY VG RH Screws

The Reverse-Head Socket is a special driver bit for ASSY VG RH screws, providing a snug fit for their head type and thus easily transferring the high torque required for installation. This socket is designed for use in conjunction with the associated Magnetic Bit Case Holder.



Reverse Head



Snug Fit



Optimum Torque Transfer

Magnetic Bit Case Holder VG RH

Eases Installation of ASSY VG RH Screws

Using the built-in magnet, the Bit Case Holder holds the screw and bit in place at the start of installation, before the threads have engaged with the wood fiber. Therefore, the Bit Case Holder can be used for a more efficient overhead installation. It is designed for use with the Reverse-Head Socket for ASSY VG RH screws, simplifying their installation.

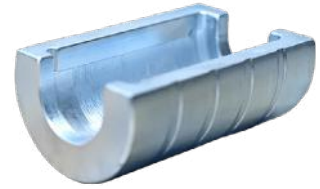

Reverse Head



Efficient Overhead Installation



Magnetic

Magnetic Bit Case Holder SK, VG CSK

Eases Installation of ASSY SK and VG CSK Screws

The Magnetic Bit Case Holder is designed for use with the Bit Holder Socket for RW 50 bits for installation of ASSY SK and VG CSK screws. Using the built-in magnet, the Bit Case Holder secures the screw and the RW bit together to hold the connection in place during installation.



Countersunk Head



Efficient Overhead Installation



Magnetic





Kingsway Royal Alex LRT Stations

Edmonton, Alberta

Appendix

APPENDIX A: GENERAL CONNECTION INFORMATION	68
Main and Side Members	68
Fastener Angle Notation	68
Lateral Connections	69
Brittle Failure Modes in Wood	70
APPENDIX B: ADDITIONAL GEOMETRY CONSIDERATIONS	71
Wood Members at an Angle	71
Forces at an Angle to Grain	71
End and Edge Distance Requirements for Reinforcing Screws	71
Screws Reinforcing Connections Loaded Perpendicular to Grain	72
Screws Reinforcing Connections Loaded Parallel to Grain	72
Geometry Requirements for Inclined Fully Threaded Screws	73
Inclined Screws in Reverse Loading	73
Geometry Requirements for Toe Screws	74
Geometry Requirements in Screw Crosses	74
Brittle Failure Modes Related to Axially Loaded Screws	75
Inclined Screws in Three-Member Connections	75
APPENDIX C: STEEL PLATE DETAILING	76
Steel-to-Wood Connection Detailing	76
APPENDIX D: SERVICE CONDITIONS AND DURABLE DESIGN	78
Service Conditions and Other Factors Impacting Corrosion	78
Other Fastener Degredation Mechanisms	81
Design and Detailing Considerations for Durability	82
APPENDIX E: INSTALLATION GUIDELINES	87
General Installation Instructions	87
Predrilling and Pilot Holes	89
Fastener Installation in Steel Side Plates	90

Appendix A: General Connection Information

Main and Side Members

In timber design, the main member is typically the primary structural element into which the tip of the screw penetrates, while the side member is the element being attached, where the screw head is located. For partially threaded screws, selecting a length that ensures threads are only embedded in the main member helps maintain optimal connection strength and allows the connection to be properly tightened.

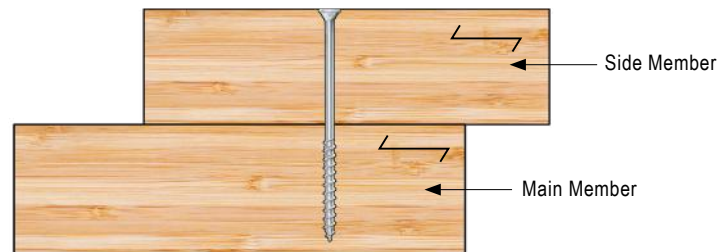

Two-Member Connection

Fastener Angle Notation

Two angle parameters for connections are defined as follows:

- α represents the relative angle between the fastener axis and the grain orientation
- β represents the smallest angle between the fastener axis and the shear plane

For additional information, refer to CSA O86:24 Clause 12.12.4.2.

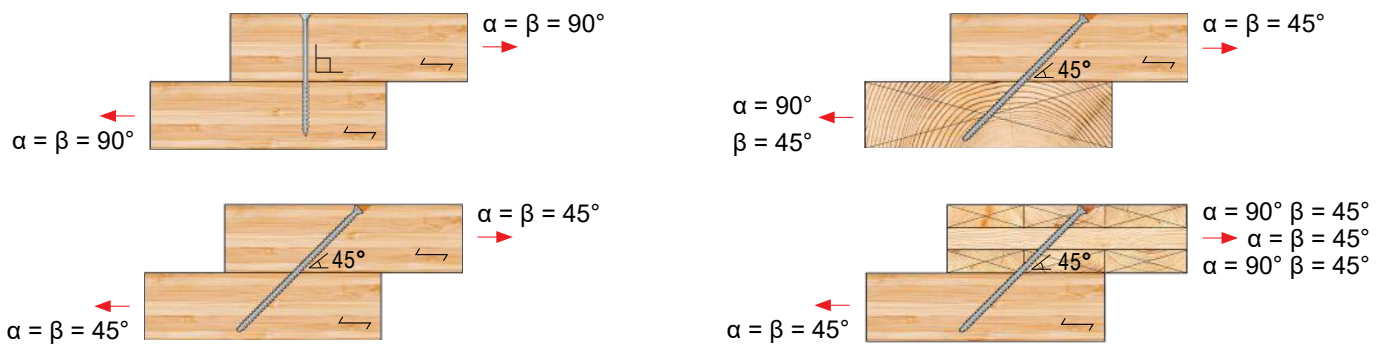

Angle Parameters for Various Configurations

Lateral Connections

Lateral connections can be designed for ductile failure modes. To ensure ductile behavior, a connection should be designed in such a way that fastener yielding is the governing failure mode. Additionally, the designer should perform appropriate checks to avoid brittle modes of failure in the wood.

Fastener Yield Modes

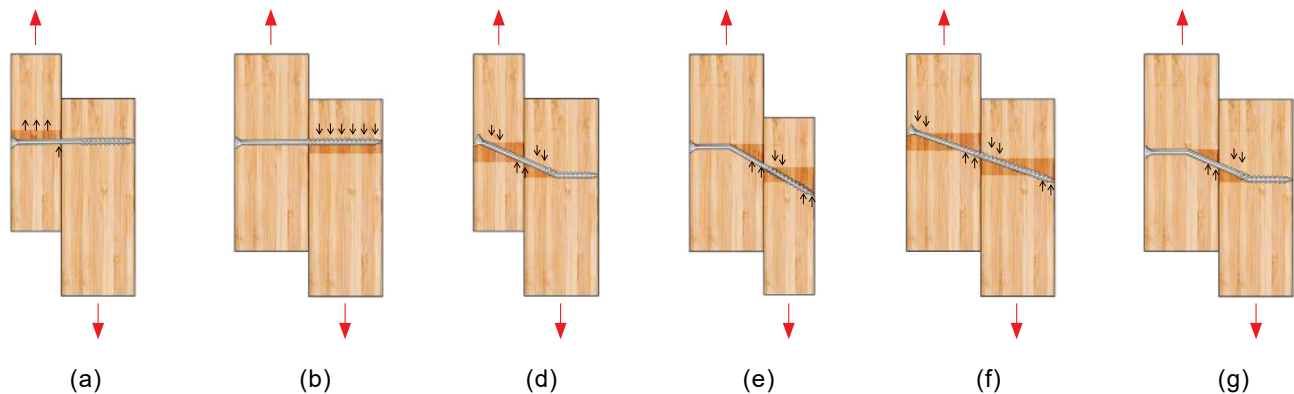

CSA O86:24 Yield Modes for Two-Member Connections

As illustrated above for two-member connections, fastener yield modes are primarily a function of the embedment failure in the wood member or yielding failure of the fastener, or a combination of both (Yield Mode (c) only applies to three-member connections and is not shown here for clarity).

Self-tapping screws have higher bending yield strength, f_y , compared to traditional lag screws. These f_y values are provided in the specified design value tables for different series of MTC Solutions fasteners. With self-tapping screws, yield modes where a plastic hinge forms in the fastener are the most desirable yielding mechanisms as they offer high ductility. As a rule of thumb, a lateral connection typically reaches Yield Mode (g) at a minimum penetration length of $8D$ based on the yield equations in CSA O86:24.

Brittle Failure Modes in Wood

For connections with multiple closely spaced large-diameter fasteners, the resistance might be limited by wood brittle failure modes due to tension and/or shear failure in parts of the wood members surrounding the fasteners before each fastener reaches its bearing capacity in the group. These failures can occur in parallel- or perpendicular-to-grain loading directions. Common brittle failure modes that need to be checked for large dowel-type fasteners include, but are not limited to:

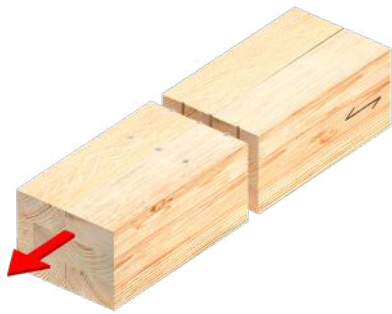

Net Tension Failure Mode

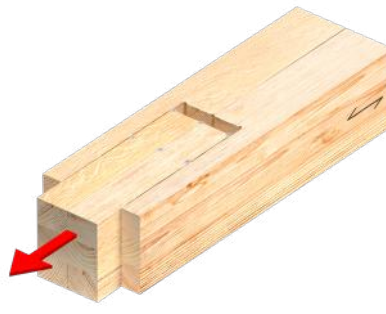

Group Tear-Out Failure Mode

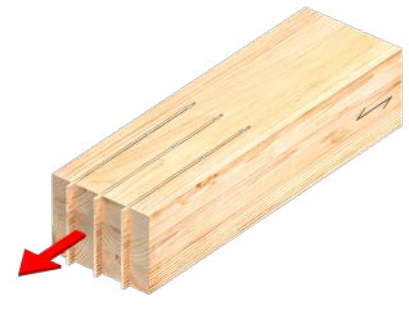

Row Shear Failure Mode

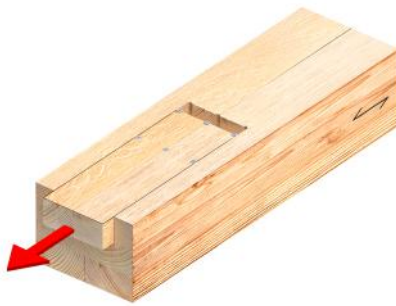

Plug Shear Failure Mode

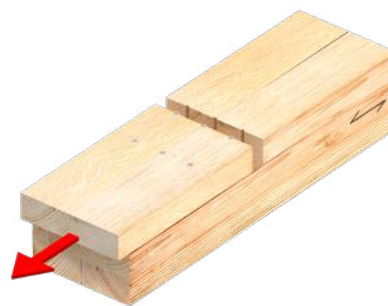

Step Shear Failure Mode

Brittle Failures in Parallel-to-Grain Loading per CSA O86:24 Clause 12.12.10.7

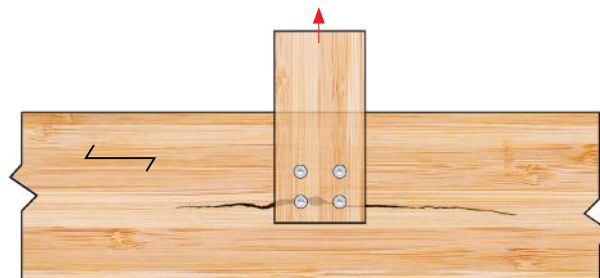

Splitting Failure in Perpendicular-to-Grain Loading

The minimum fastener spacing, edge distance, and end distance requirements specified elsewhere in this document are intended to prevent splitting of wood that can occur during installation of closely spaced fasteners. A fastener layout that conforms to the minimum spacing and end/edge distance requirements does not ensure adequate strength to preclude brittle failure modes from occurring when wood member connections are loaded. Designers must ensure that members connected with self-drilling dowels or self-tapping screws conform to the requirements outlined in CSA O86:24 (e.g., Clauses 12.4.4, 12.12.10.7, and 12.12.10.8).

Appendix B: Additional Geometry Considerations

Wood Members at an Angle

In cases where fasteners are installed in members with miter cuts, the corresponding end and edge distances are measured along and across the grain, respectively.

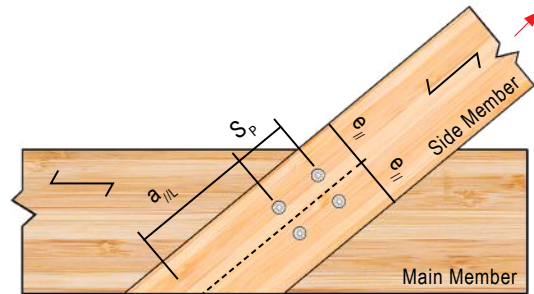

Wood Member at an Angle

Forces at an Angle to Grain

The direction of the force applied to the fastener must be considered when identifying loaded ends and edges.

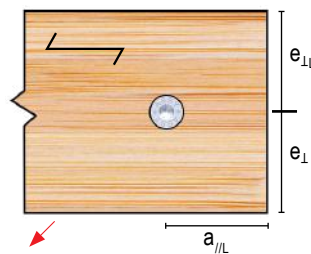

Wood Member Loaded at an Angle

End and Edge Distance Requirements for Reinforcing Screws

Reinforcing screws should be placed as close to the expected location of peak stress application as possible. Minimum end and edge distances still apply.

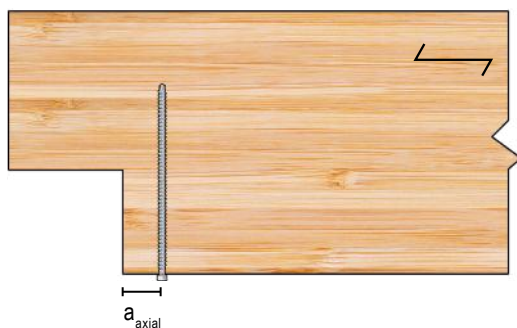

End Distance Requirements for Reinforcing Screws

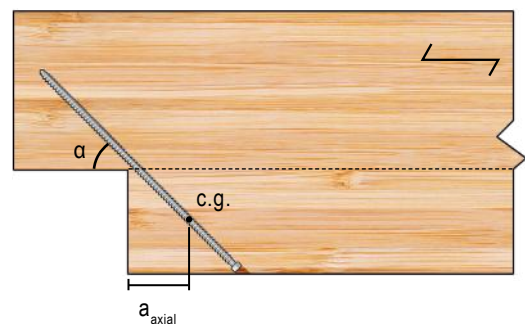

Note: c.g. is the center of gravity of the screw below the fracture point.

End Distance Requirements for Inclined Reinforcing Screws

Screws Reinforcing Connections Loaded Perpendicular to Grain

For the connection type shown in the figure below, reinforcing screws should be placed as close to the origin of stress cracking as possible. Maintaining a minimum screw spacing of $1.5D$ may help to prevent screw collision. The screw spacing follows the usual geometry requirements for axially loaded fasteners. To ensure accurate installation, a pilot hole may be required along the desired fastener path.

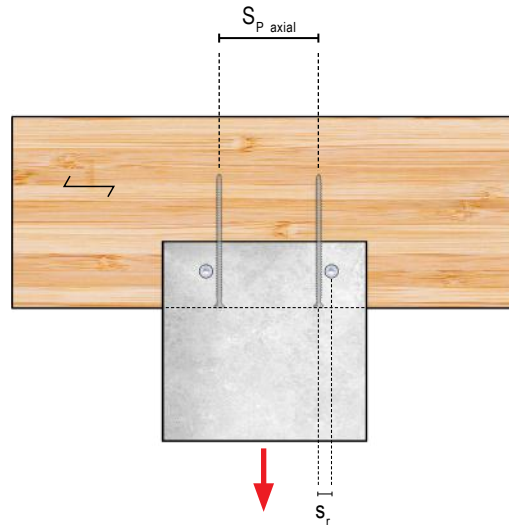

Geometry Requirements for Screws Reinforcing Bolted Connections Loaded Perpendicular to Grain

Screws Reinforcing Connections Loaded Parallel to Grain

Reinforcing screws should be placed as close to the origin of stress cracking as possible (i.e., s_r should be minimized). A minimum distance of $1.5D$ should be provided between the reinforcing screws and the other dowel-type fasteners ($s_r > 1.5D$), provided that the respective axes are oriented perpendicular to each other and that there is no screw collision. To be effective, reinforcing screws must be placed on the same side of the bolt that bears against the wood member (as shown in the figure below) to resist splitting along the grain.

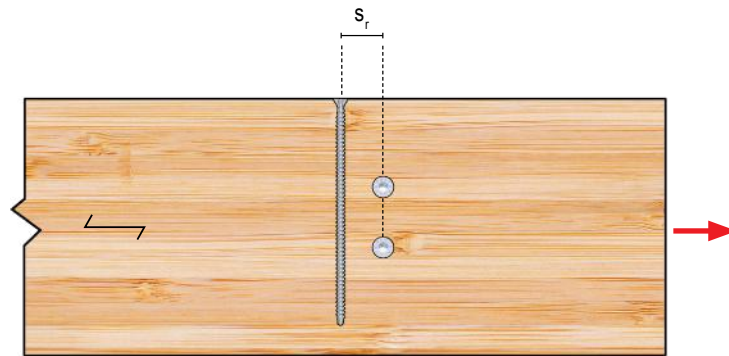

Geometry Requirements for Screws Reinforcing Bolt Connections Loaded Parallel to Grain

Geometry Requirements for Inclined Fully Threaded Screws

For inclined screw connections, the center of gravity of the threaded portion of the screw, excluding the tip and unthreaded section, in both side and main member, C_s and C_m , respectively, is used when applying end and edge distance requirements in accordance with CSA O86:24 Clause 12.12.5.

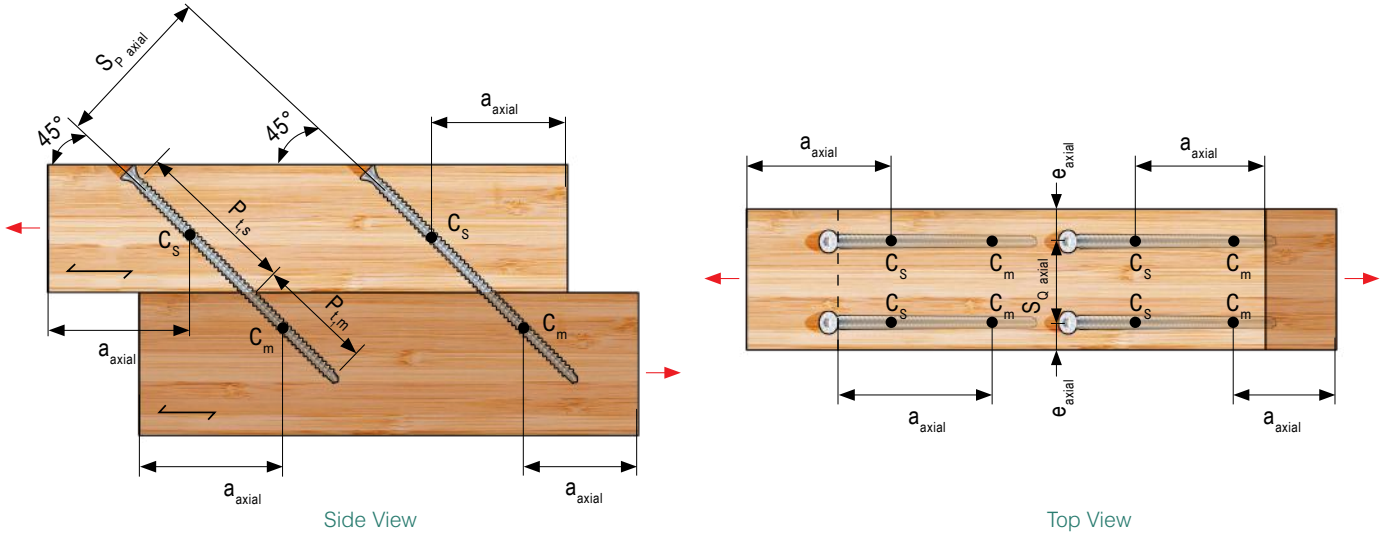

Inclined Screws in Reverse Loading

The inclined screw configuration illustrated below is not recommended when the screw is in shear-compression, as it may lead to panel separation and screw bending due to uplift forces. For reverse loading or connections subjected to loads oriented in multiple directions, screw crosses are recommended as they offer more stability.

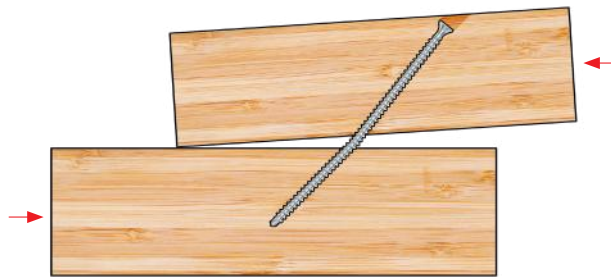

Inclined Screw in Reverse Loading

Geometry Requirements for Toe Screws

For toe screw connections, the center of gravity of the portion of the screw in each member is used when applying end and edge distance requirements. Swelling and shrinkage of wood members due to changes in moisture content should be considered for toe screw connections. Load eccentricities should be avoided to maintain connection stability. Additionally, toe screw connections should have a tight joint to develop compression, essential to effective function.

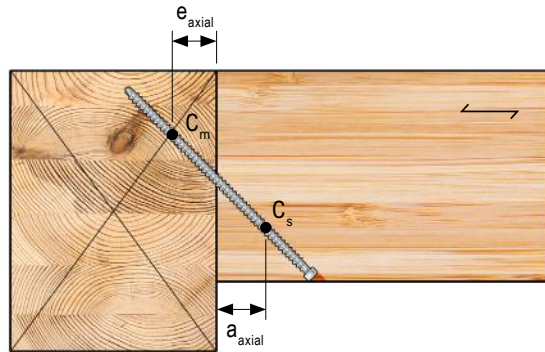

Geometry Requirements in Screw Crosses

Screws in a cross pair need to be offset from one another by at least $1.5D$ to accommodate installation tolerances and prevent collision.

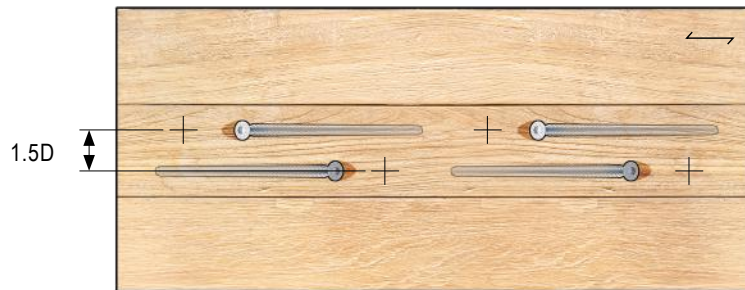

Top View

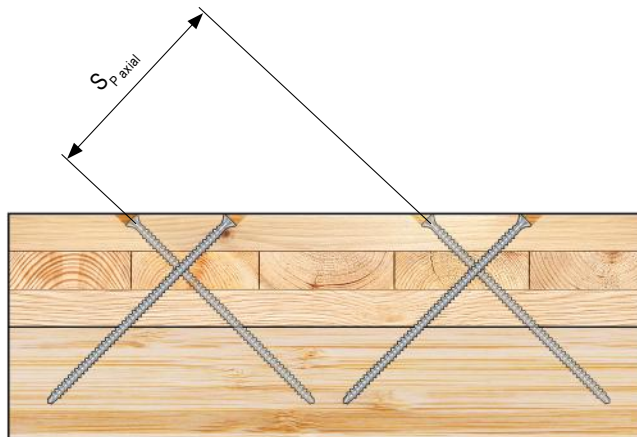

Side View

Fasteners acting as a pair should be installed at the same angle, opposite to each other, with the same thread penetration lengths in either member. Typically, the fasteners cross at either the central plane of the side member or at the shear plane between the two members. Fasteners crossing at the centroid of the side member should be preferred over those crossing at the shear plane, as the former minimizes loading eccentricities that can lead to connection instability.

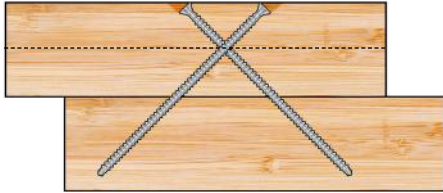

Fasteners Crossing at the Central Plane of the Side Member

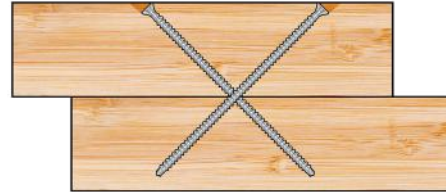

Fasteners Crossing at the Shear Plane

Brittle Failure Modes Related to Axially Loaded Screws

In two-member, steel-to-wood connections, there is a possibility of block shear failure, plug shear failure or perpendicular to the grain split failure as shown below, when the screw axis is parallel to the load direction. This failure mechanism depends on the screw spacings, effective thread penetration length, and the angles of the screw axis and loading direction with respect to the wood grain orientation. The worst-case scenario occurs at a 90° angle.

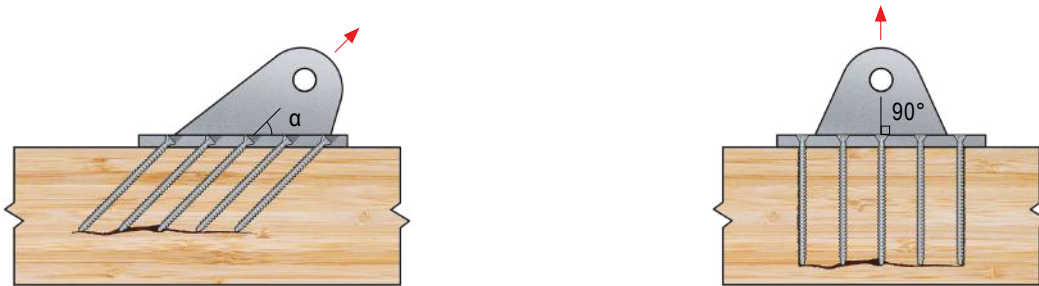

Splitting Failure Perpendicular to Grain in Inclined Steel-to-Wood Connections

Inclined Screws in Three-Member Connections

The loading configuration in the figure below (left) may cause splitting failure in wood. Therefore, such detailing should be avoided for symmetrical, three-member joints. If necessary, the screws in symmetrical joints should overlap by at least $4D$ (not including the tip).

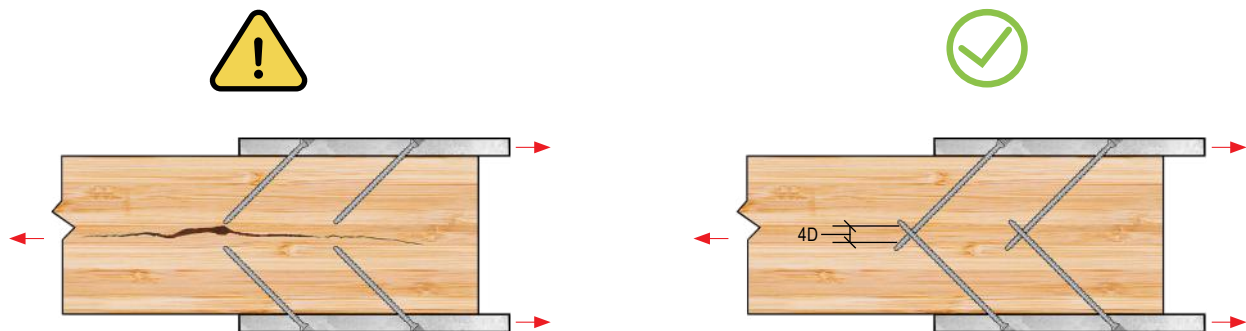

Inclined Screws in a Three-Member Connection

Appendix C: Steel Plate Detailing

Steel-to-Wood Connection Detailing

A steel-to-wood connection can be established with ASSY self-tapping fasteners using one of the following methods:

- Bear the fastener's head directly on the steel plate,
- Countersink the fastener head into the steel plate, or
- Install each fastener with a washer

ASSY Kombi and Kombi LT fasteners with hex heads are designed to provide a snug fit with their tapered shoulder in the steel side member. ASSY VG CSK and ASSY Ecofast fasteners with countersunk heads are reliable alternatives for steel-to-wood connections.

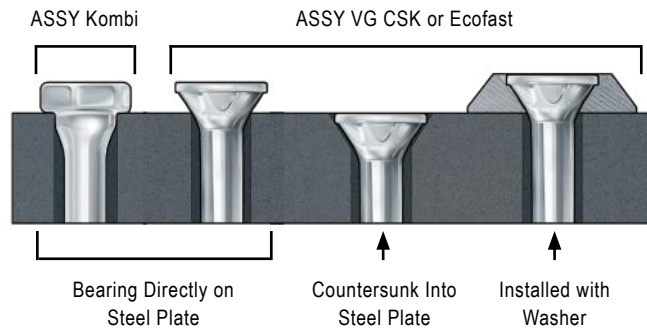

The steel side member must be predrilled prior to fastener installation. Steel plate holes are generally kept 1/16 in. [1 mm] larger than the nominal screw diameter, D. If a coating is present on the steel plate, holes must be oversized to account for the coating thickness.

Table C.1 - Countersunk Fastener Head and Shank Dimensions

Nominal Fastener Diameter [D]	Fastener Type	D _{head}	D _a	D _p	t _p	Drive Bit
		in. [mm]				
1/4 [6]	Ecofast	0.472 [12]	0.276 [7]	0.622 [15.8]	0.173 [4.4]	RW 40
5/16 [8]	Ecofast	0.591 [15]	0.354 [9]	0.748 [19]	0.197 [5]	
	VG CSK	0.591 [15]	0.354 [9]	0.748 [19]	0.197 [5]	
3/8 [10]	Ecofast	0.728 [18.5]	0.433 [11]	0.898 [22.8]	0.232 [5.9]	
	VG CSK	0.787 [20]	0.433 [11]	0.945 [24]	0.256 [6.5]	
1/2 [12]	VG CSK	0.866 [22]	0.512 [13]	1.039 [26.4]	0.264 [6.7]	

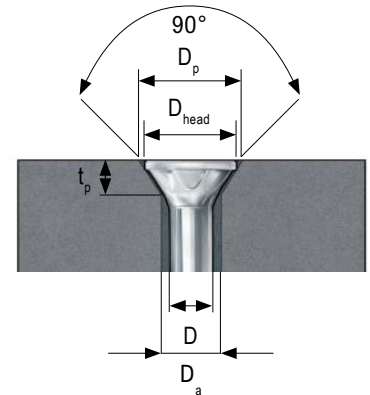

Table C.2 - Kombi Fastener Head and Shank Dimensions

Nominal Fastener Diameter [D]	Fastener Type	D _{head}	D _{shd}	D _a	Drive Bit
in. [mm]		in. [mm]			
5/16 [8]	Kombi	0.472 [12]	0.315 [8]	0.354 [9]	RW 40 or 19/32" Hex Socket
3/8 [10]	Kombi	0.591 [15]	0.394 [10]	0.433 [11]	
1/2 [12]	Kombi	0.669 [17]	0.472 [12]	0.511 [13]	

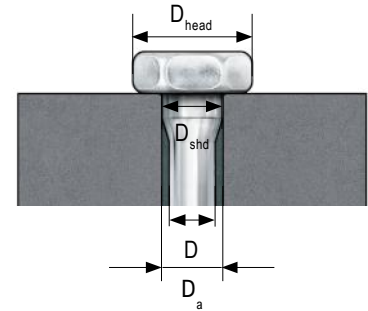
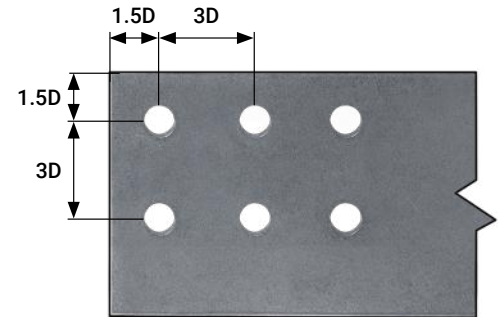

Table C.3 - Steel Plate Geometry Requirements for Fully Threaded Fasteners

Geometry Requirement	Minimum Dimension
	Any D
Distance between fasteners in a row	3D
Distance between rows of fasteners	3D
End distance	1.5D
Edge distance	1.5D



Note:

- These values are in accordance with ICC-ESR-3178 (2023) Section 4.2.2.

Minimum Steel Plate Thickness Below Fastener Head

For inclined screws in steel side members, their head should be completely countersunk within the milled hole as shown in the figure below. To completely countersink the screw head, the steel plate must be milled at an appropriate angle and to the correct head dimensions. To ensure sufficient stability of an inclined screw with a countersunk head, maintaining a minimum thickness, *s*, below the head is recommended. For fasteners utilized with wedge washers, refer to the minimum and maximum plate sizes in the Accessories chapter.

- $\alpha > 45^\circ$ $s \geq 1/8" [3 \text{ mm }]$
- $30^\circ \leq \alpha \leq 45^\circ$ $s \geq 5/64" [2 \text{ mm }]$

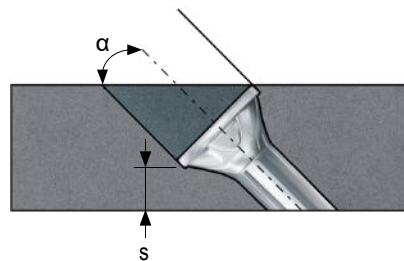

Appendix D: Service Conditions and Durable Design

When selecting fasteners and materials for timber construction, multiple factors must be carefully considered to ensure a durable connection, including not only corrosion resistance, but also susceptibility to hydrogen embrittlement (HE), and the impact of wood swelling and shrinkage. Durable design extends beyond the fasteners themselves, requiring a holistic approach that takes into account the properties of the timber. The wood must have sufficient resistance to maintain long-term durability, with dry service conditions generally being more favorable.

Wet service conditions, in particular, can significantly affect the overall resistance of the connection, necessitating the application of adjustment factors to ensure structural integrity. Additionally, moisture exposure can compromise the durability of the timber itself, underscoring the importance of selecting the appropriate treatment to protect against rotting.

Corrosion, a natural process that occurs when metallic materials interact with their environment, cannot be entirely prevented. However, careful planning, detailing, and the use of protective measures can mitigate its damaging effects. It is the responsibility of design professionals to consider all these parameters – environmental factors, service conditions, galvanic (bimetallic) corrosion, HE, and timber treatment – to ensure the long-term durability and safety of the structure. This appendix provides comprehensive guidance on addressing these challenges, with a particular focus on understanding service conditions and incorporating durable design recommendations.

Service Conditions and Other Factors Impacting Corrosion

Maintaining dry service conditions for timber connections as defined in CSA O86:24 is not only crucial for corrosion resistance but also serves to prevent decay of the wood fiber. As wood fibers absorb more moisture, they lose strength, which is why reduction factors are imposed on the strength properties and connection resistance. Understanding these service conditions is essential for ensuring both the durability of the connection and the overall structural integrity.

Dry Service Conditions

Applications falling within the dry service condition category are generally confined to indoor environments but may extend to exterior settings where connections are sheltered and unexposed to the elements. It is essential to account for the possibility of prolonged moisture presence during construction, as this might necessitate a reclassification of the service conditions or pre-service conditions, requiring a modification of the adjustment factor K_{SF} (see CSA O86:24 Table 12.1). Regular corrosion-resistant fasteners with a minimum 8 micron A3K surface coating are intended for use in dry service conditions. For structures exposed to the elements, careful consideration should be given to protection of members and connections when designed using dry service conditions.

Wet Service Conditions

This category applies to connections that do not meet dry service conditions and that do not fall within the Increased Corrosion Risk category (see Page 13). This typically applies to connections exposed to the elements such as outdoor construction projects, exterior structures permanently exposed to the elements, and sheltered structures that are still subject to precipitation or high humidity. This may also apply to connections in indoor applications such as indoor pools or greenhouses. The following summarizes circumstances in which wet service conditions may apply to a connection design:

- The moisture content (MC) of the wood exceeds 19% at the time when the connection is fabricated, i.e., the pre-service conditions. Refer to CSA O86:24 Table 12.1 for adjustment factors for connections fabricated in green wood.
- The connection is exposed to direct wetting from elements such as rain, snow, splashing, dripping, or condensation, impeding quick and effective drying.
- The equilibrium MC (EMC) of wood exceeds 15% averaged over the year or 19% at any given time (according to CSA O86:24). Designers can estimate EMC from the following graph.

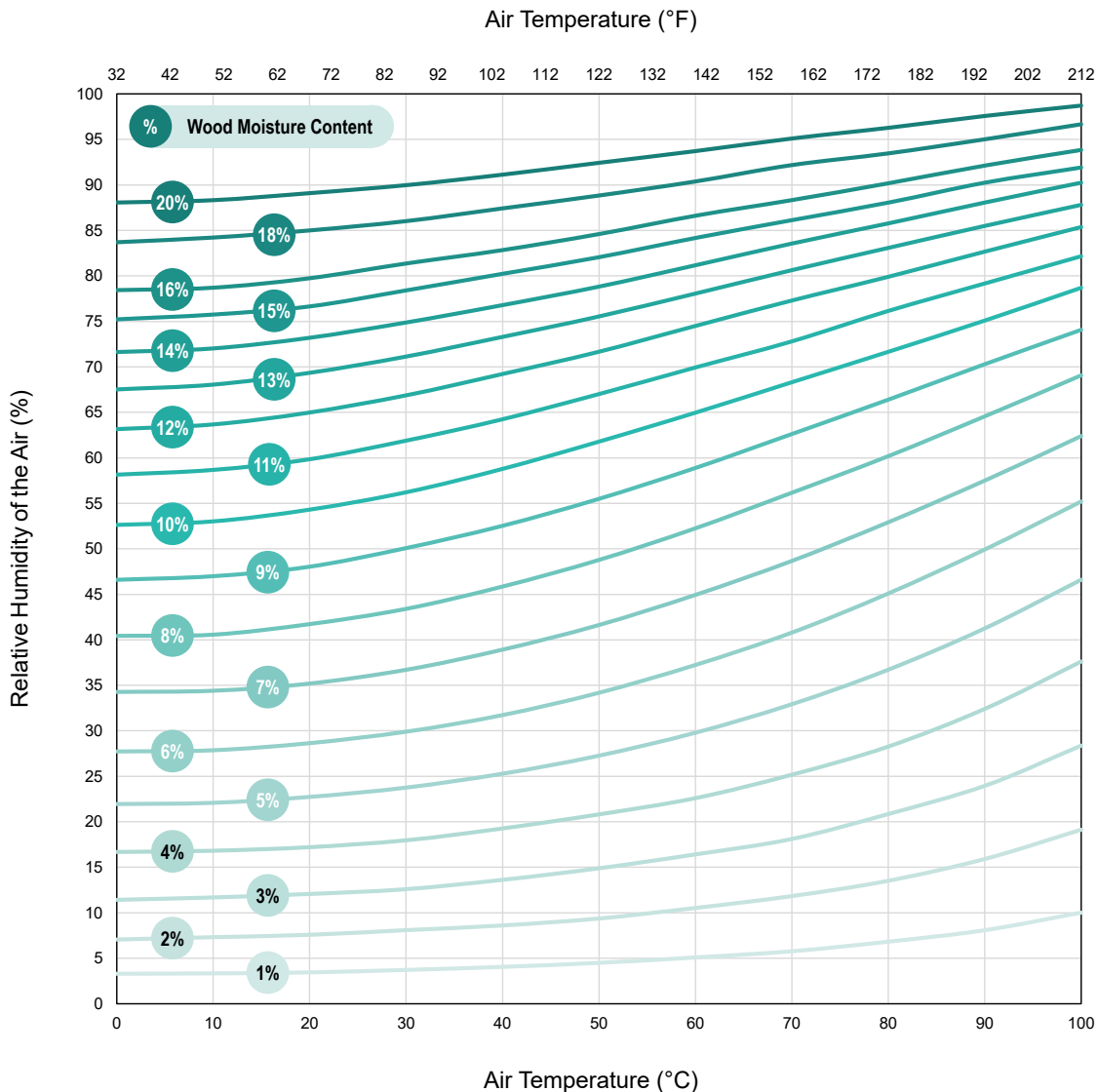

Increased Corrosion Risk Categories

Waterfront Service Conditions

Connections exposed to highly corrosive environments such as ocean salt air and salt water require extreme corrosion-resistant fasteners. According to FEMA, this can apply to structures within 3,000 ft. of a salt-water body, but this may vary dependent on local regulations. Fasteners exposed to waterfront service conditions may require additional corrosion resistance as outlined in AC 257, such as that provided by A4 stainless steel.

Exposure to Aggressive Substances

This category encompasses connections exposed to industrial emissions, agricultural chemicals, specific soil types, de-icing salts, chlorine, acid rain, and various other corrosive substances. It is recommended that a corrosion risk analysis be performed by a qualified professional and that the service life of the connection be evaluated. Fasteners exposed to aggressive substances may require additional corrosion resistance as outlined in AC 257, such as that provided by A4 stainless steel.

Chemically Treated Lumber

Wood fiber treatment may increase the risk of corrosion, especially in the presence of moisture. Lumber treated with certain preservatives, such as copper azole (CA) and alkaline copper quat (ACQ), exhibits an elevated tendency to induce corrosion in metals within high-moisture environments. This heightened corrosive effect is ascribed to copper's highly galvanic nature, making one of the metals in the couple the anode and accelerating corrosion (see the Bimetallic Contact Corrosion section for more details). Compared to CA, ACQ is more corrosive. Its organic components attract moisture, intensifying fastener corrosion. Therefore, applications involving chemically treated lumber may require fasteners with a high level of corrosion resistance.

If there is uncertainty about the specifics of treatment chemicals or the environmental conditions, MTC Solutions recommends choosing stainless steel hardware of an appropriate grade. However, it must be noted that MTC Solutions has not evaluated all chemical formulations or treatment processes. While manufacturers may provide independent test results or additional product details, MTC Solutions does not endorse or provide opinions on such third-party information.

Other Fastener Degredation Mechanisms

Bimetallic Contact Corrosion

Galvanic (bimetallic) corrosion is an electrochemical process where dissimilar metals (e.g., carbon steel and aluminum) are immersed in a conductive solution (e.g., water), leading to corrosion of the more anodic material. This electrochemical process happens without the need for an external electrical charge. Effective strategies for mitigating galvanic corrosion include preventing the accumulation of conductive solutions, such as water, and eliminating contact between dissimilar metals. If this is not possible, physical separation of the two metals using a nonconductive material is a viable alternative. In situations where dissimilar metals cannot be avoided, it is considered best practice to opt for fasteners with a lower galvanic corrosion potential such as stainless steel.

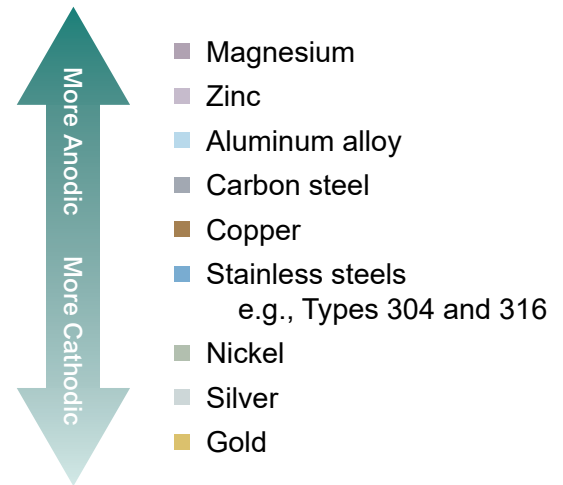

Galvanic Series of Metals and Alloys

Hydrogen Embrittlement (HE)

HE is a delayed embrittlement mechanism that can lead to the degradation and eventual failure of fasteners. It is crucial to differentiate HE from general corrosion resistance, as even fasteners considered ductile may become embrittled if made from susceptible materials or used in inappropriate applications. There are two types of HE that must be considered and mitigated when working with self-tapping screws: internal and environmental.

Internal Hydrogen Embrittlement (IHE)

Fasteners supplied by MTC Solutions meet ISO 2702 standards during the manufacturing process and have a hardness below 390 HV in order to mitigate IHE. In addition, MTC Solutions utilizes post-manufacturing inspection techniques in accordance with ISO 4042 and ISO 15330 to verify our fasteners meet the hardness requirements outlined in CSA O86:24, which further mitigates the risk of a brittle HE failure.

Environmental Hydrogen Embrittlement (EHE)

EHE occurs when there is re-introduction of hydrogen from the environment. There are two main sources of hydrogen in the environment: water and acid. It is the responsibility of the designer to mitigate EHE potential. Fasteners typically encounter water during on-site storage or due to wet service conditions, and typically encounter acid through cleaning processes. To mitigate EHE from these causes, MTC Solutions recommends the following:

- Fasteners shall be stored in a dry environment.
- Carbon steel fasteners with a maximum core hardness above 36 HRC (360 HV), such as MTC carbon steel fasteners, shall not be used in wet -service conditions in accordance with CSA O86:24.
- Fasteners shall not come into contact with acid-based cleaning solutions.

Design and Detailing Considerations for Durability

Suggested Fastener Specification Language

1. All fasteners for timber applications shall conform to CSA O86:24.
2. All case-hardened, carbon steel, self-tapping wood screws must have a core hardness ≤ 390 HV, in accordance with ISO 2702. For case-hardened, carbon steel fasteners used in wet service conditions, the core hardness must be ≤ 360 HV. Wet service applications will require additional measures to prevent corrosion.
3. All case-hardened, carbon steel, self-tapping wood screws with a core hardness between 360 HV and 390 HV must have an additional quality assurance plan in accordance with ASTM F606 Clause 7 or ISO 15330.
4. Electroplated fasteners must be manufactured per ISO 4042 or ASTM F1941 with a zinc coating thickness of at least 8 microns.
5. Follow the manufacturer's installation instructions, including recommended tools, drive-in torque limits, and predrilling requirements.
6. For dry service conditions, the timber moisture content (MC) should average 15% or lower throughout the year and must not exceed 19% at any time.
7. Fasteners must be stored in a dry environment prior to installation to prevent exposure to moisture and other corrosive elements.
8. The shop drawings and Bill of Materials for all fasteners must be reviewed and approved by the Structural EOR prior to installation.

Sheltered Connections

Timber connections that are sheltered but may be exposed to wind-driven rain or high humidity require careful detailing to prevent moisture-induced degradation. Exposed end grain should be avoided to reduce excess moisture absorption due to capillary effects. Considerations should include protective overhangs, end caps, or other flashings to minimize exposure and the use of corrosion-resistant fasteners suitable for the expected moisture levels.

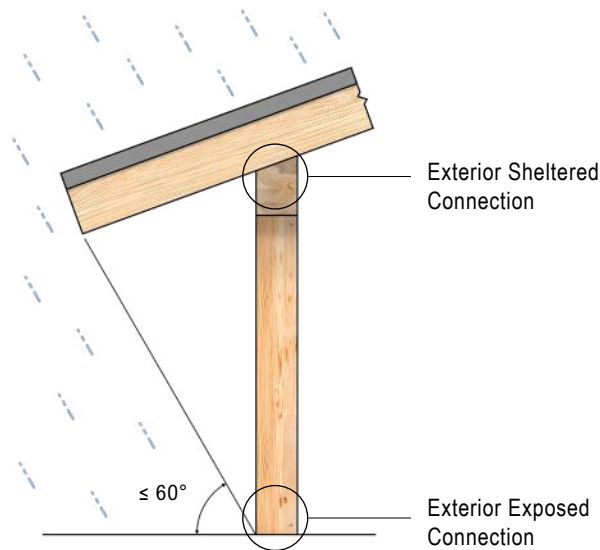

Sheltered and Exposed Connections

Moisture Management During Construction

During the construction process, shield members with covers or use strategic positioning in areas protected from direct rainfall.

Avoid water pooling by detailing elements and connections for adequate drainage to mitigate corrosion and degradation of the wood fiber. Examples of proper detailing can include sloping surfaces away from timber elements or providing drainage channels that prevent water from collecting. A Building Envelope consultant can provide further guidance.

Uneven drying, such as rapid drying of a portion of an element from direct sun exposure, can create nonuniform stress distributions in timber elements, potentially leading to excessive checking. Ensure that timber elements are allowed to dry uniformly with shading techniques or by rotating timber elements during the drying process.

Moisture-Related Movement

In applications where variations in wood MC are expected, special detailing is required to accommodate the natural shrinkage and swelling of the timber. As sawn lumber primarily undergoes dimensional change in the cross-section (aligning with the tangential and radial directions relative to grain), designers should account for the anticipated movement. Improper connection detailing that does not consider moisture-induced dimensional changes can give rise to the development of restraint forces, resulting in wood splitting or reduced connection performance. To assist with detailing for moisture-related movement, designers can refer to Chapter 13 of the USDA Wood Handbook which states the expected change in dimension (ΔD) within the MC range of 6–14% can be estimated using a dimensional change coefficient derived from the dimension at 10% MC:

$$\Delta D = D_I [C_T (M_F - M_I)] \quad (\text{eq. 2})$$

$$C_T = \frac{1}{\left(FSP \cdot \frac{100}{S_T} \right) - FSP + M_I} \quad (\text{eq. 3})$$

D_I	dimension in units of length at start of change;
C_T	dimensional change coefficient for the tangential direction;
M_F	moisture content (%) at end of change;
M_I	moisture content (%) at start of change;
FSP	fiber saturation point (assumed at 30% MC unless noted otherwise);
S_T	tangential shrinkage

Note:

- For calculations in the radial direction, C_R (dimensional change coefficient in the radial direction) and S_R (radial shrinkage) replace C_T and S_T , respectively.

Table D.1 - Dimensional Change Coefficients for Common Wood Species in Mass Timber Construction

Species	Dimensional Change Coefficient	
	C_R	C_T
Southern Pine (loblolly)	0.00165	0.00259
Douglas Fir (interior west)	0.00165	0.00263
Spruce-Pine-Fir (black spruce)	0.00141	0.00237

Note:

- Excerpted from Wood Handbook, Wood as Engineering Material (2021) Table 13-15.

Steel Side Plates

Connections with steel side plates can restrict the natural movement of wood, preventing it from expanding or contracting with changing ambient conditions. It is preferable to allow the wood to shrink or swell with minimal restraint to maintain its structural integrity. In some cases, connectors can be designed with slotted holes to accommodate moisture-related movement. Except for connections in CLT, it is recommended to limit the distance between the outermost fasteners perpendicular to the grain to no more than 125 mm (5 in). This limitation helps control restraint forces within a connection, preventing wood splitting and maintaining connection performance.



Maximum Spacing Between Outermost Rows of Fasteners

Green Wood

On occasion, fasteners are installed into green wood (with over 30% MC), which undergoes significant drying in the early stages of a building's service life. When wood is below 19% MC, any water present will be bound in the wood cell walls. Above the fiber saturation point (FSP), typically around 30% MC (depending on wood species), all the additional water will be free water within the lumen. Between 20% and 30% MC there is a transition phase, where some free water starts to accumulate. As the MC increases, any water will be absorbed by the wood cell walls as "bound water," which causes the cell walls to thicken. Once the MC exceeds the FSP, additional "free water" will be stored in the cell lumen. The changes in cell wall thickness correspond with dimensional changes, which are primarily perpendicular to the grain. It is important to detail to accommodate the shrinkage that will occur as the wood dries out.

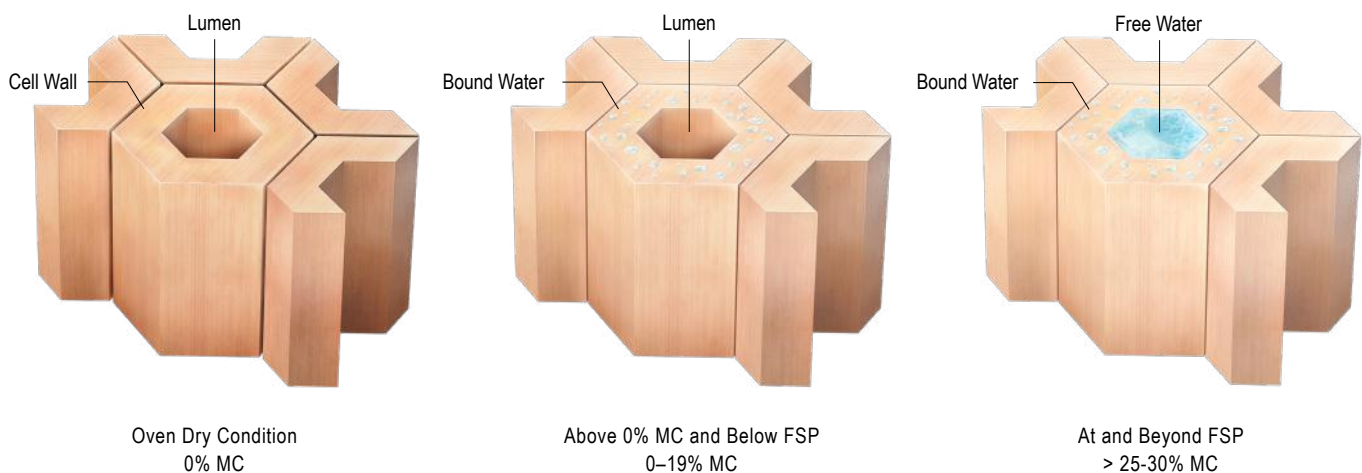

Water Movement in Wood Cells

End Grain Connections

Connections at the end grain demand careful consideration when subjected to differential drying—a common cause of checking—in heavy timber members. Most building codes include special provisions for screws in withdrawal installed at a 0° angle in the end grain, motivated by the potential development of checks and splits along the grain. In some cases, the fastener axis may run parallel to these voids, resulting in lower capacity, particularly when the fasteners are loaded in withdrawal. As an example, installing fasteners at a 30° angle to the grain enables the fasteners to pass through checks and splits.

The following recommendations for fasteners in withdrawal in end grain applications can help ensure desired connection performance:

- Install the screws at an angle relative to grain greater than approximately 30°
- Use a minimum of 4 screws in each connection
- Ensure a minimum thread penetration length of $20D$
- Apply the appropriate angle-to-grain reduction factor, J_a , and end grain factor, J_E , when calculating the design capacity



Green Wood



Dry, Checked Wood



Dry, Checked Wood
with Inclined Screws

Appendix E: Installation Guidelines

A proper installation procedure is critical for a connection to perform as intended by the design engineer. Installing high-capacity fasteners into critical connections requires the utmost level of accuracy and craftsmanship. The following sections provide information on why it is important to create and follow an installation procedure, as well as additional tips and best practices. It is important to follow the instructions outlined in these sections to prevent reduced connection capacities, undesired connection performance, and fastener-related issues such as breakage, collision, and deviation.

General Installation Instructions

I Use the Correct Bit

MTC Solutions fasteners should only be driven using RW bits, or appropriately sized Torx bits. This approach ensures good centering and positioning with optimal torque transmission.

Note:

- For information on bit selection refer to the tables on the Product Overview page for each fastener.

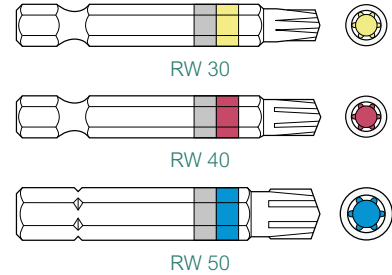

II Use the Correct Drill

Use low-RPM, high-torque drills to install MTC Solutions fasteners. Avoid excessive acceleration and deceleration during the drive-in process. The operating speed should be maintained at 300–400 RPM. Do not use impact drills. Do not over-torque fasteners. Refer to product chapters for allowable insertion torque values. Use the appropriate drill chuck size according to the fastener diameter:

E.1 - Recommended Drill Bits and Power Drill

Nominal Fastener Diameter [D]		HSS Drill Bit		Power Drill Voltage
in.	[mm]	in.	[mm]	V
1/4	[6]	5/32	[3.9]	20
5/16	[8]	3/16	[4.8]	20
3/8	[10]	1/4	[6.4]	60
1/2	[12]	17/64	[6.7]	60*
9/16	[14]	5/16	[7.9]	60*

* A double handle drill is recommended.

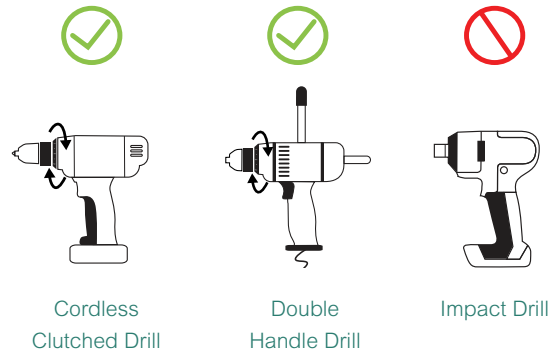

III Align Drill Bit Axis

The drill bit axis must be parallel to the fastener axis during installation to ensure proper torque transmission and to avoid stripping the housing of the bit.

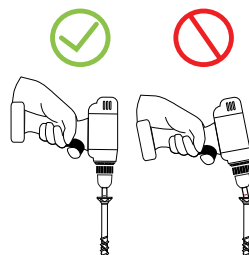

IV Decrease RPM

To avoid over-torquing the screw, especially in steel-to-wood connections, decrease the rotation speed about 1/2 in. away from the final installed position.

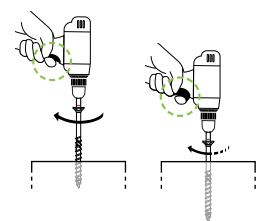

V Do Not Press on the Drill

Do not apply excessive pressure on the drill once the fastener is engaged, as even a slight amount of buckling will cause the fastener to deviate from its intended path. Only apply the required force or use the recommended holder case to eliminate cam-out effects.

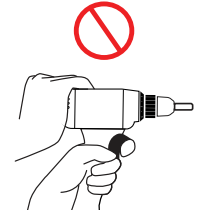

VI Prevent Fastener Deviation

Density variations in the wood, such as knots, may cause long and slender fasteners to deviate from the desired installation path. This can lead to reduced connection capacity and risk of screw collision. Predrilling or drilling pilot holes reduces the risk of fastener deviation.

VII Prevent Screw Collision

Fastener collision in the wood member can occur due to deviation from the installation path. The resulting sudden torque increase can lead to fastener breakage. Predrilling before installation reduces the risk of fastener deviation and helps avoid screw collision.

VIII Install in a One-Step Process

To avoid increased torque peaks caused by stopping and restarting the drive-in process, install the screw in one run until the head is lightly seated against the side member. If necessary, a torque wrench may be used to complete installation immediately after the fastener has been driven.

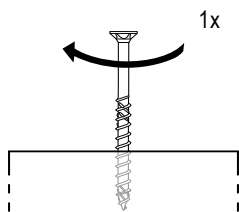

IX Installation Near Edges

In near-edge application, the fastener may be slightly inclined inward ($< 5^\circ$) to prevent the screw from curving outward and protruding out of the wood. Alternatively, predrilling can be performed to ensure a proper penetration path and reduce splitting risks.

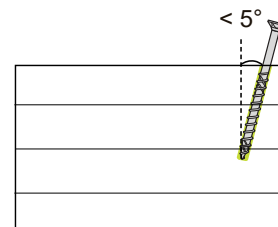

X Use Predrilling Jig

Perpendicular bearing of the screw head on a steel plate is required to allow for proper load transfer. An improper bearing can lead to unintended load interactions and breakage. Precise and accurate predrilling with accessories such as predrilling jigs avoids this risk by ensuring the proper alignment of the penetration path.

Predrilling and Pilot Holes

I Predrilling

A predrilled hole, defined as a hole with a depth equivalent to the length of the fastener, serves the purpose of reducing geometry requirements during installation. It is crucial to ensure that the diameter of the predrilled hole follows the recommended values in the table below. Utilizing predrilled holes can optimize the installation process and ensure optimal results in fastener placement in high-capacity connections.

Predrilling is recommended for installing slender fasteners into dense wood, such as SYP.

II Pilot Holes

A pilot hole, defined as a partial length hole, facilitates fastener installation by guiding the fastener during initial insertion and reducing the insertion torque. The installer should use their discretion regarding the length of the pilot hole, ensuring that the diameter does not exceed the minor diameter of the fastener. When working with steel plate connections, especially at angles, utilizing a predrilling jig for locating an accurate hole is highly recommended.

E.2 - Recommended Diameters for Predrilled and Pilot Holes

Nominal Fastener Diameter [D]	Predrilled Hole Diameter	Pilot Hole Diameter	Steel Plate Hole Diameter
in. [mm]			
1/4 [6]	5/32 [4]	≤ 5/32 [≤ 4]	9/32 [7]
5/16 [8]	3/16 [5]	≤ 3/16 [≤ 5]	3/8 [9]
3/8 [10]	1/4 [6]	≤ 1/4 [≤ 6]	7/16 [11]
1/2 [12]	17/64 [7]	≤ 17/64 [≤ 7]	17/32 [13]
9/16 [14]	5/16 [8]	≤ 5/16 [≤ 8]	N/A

Notes:

1. Full-length predrilling is intended to reduce connection geometry requirements according to self-tapping screw geometry requirements per CSA O86:24. The predrilling length should be equivalent to the fastener length.
2. Pilot holes can reduce splitting risks, and ensure a proper penetration path and faster thread engagement. A minimum pilot hole depth of 1 in. is recommended.
3. Predrilled holes exceeding the diameters listed above reduce the screw capacity.
4. These recommendations are only applicable to ASSY fasteners supplied by MTC Solutions.
5. Connection design must meet all the relevant requirements outlined in the General Notes to the Designer section.

Fastener Installation in Steel Side Plates

This section highlights the recommended installation sequence and instructions for steel-to-wood connections using lateral or inclined screws.

1. Create a list and assemble all tools required according to the type and diameter of the fasteners being installed. Installers should ensure all tools are properly calibrated.
2. Place and secure the steel side plate at the correct position on the wood main member.
3. Secure the steel plate to its specified location on the wood member using smaller-diameter locator screws, as shown in Figure a, to prevent misalignment. Design professionals should specify holes to accommodate locator screws.
4. Use of pilot holes, while optional, is recommended to ensure precise installation of screws. If desired, drill a pilot hole in every screw location with an appropriate predrilling jig and a drill bit with a proper diameter to a depth of at least 25.4 mm (1 in).
5. Clear off all sawdust inside and around the holes.
6. Start the fastener installation process from the innermost screw row to the outermost screw row, as shown in Figures b through d. In general, start with the innermost screws and move towards the outer edges, where residual stresses can be released.
7. Install the fasteners using the correct drill and bit. During the drive-in process, do not apply excessive pressure on the fasteners. Continue the installation process until the fastener head (lightly) contacts the steel plate. Stop here and remove the drill.
8. (Optional) If the use of a torque wrench is specified by the designer, individual fasteners should be torqued immediately after completion of the previous step. Switch to a torque wrench with a socket bit holder and use the correct bit to slowly drive each fastener to the specified torque. The adjusted torsional value for each fastener is listed in the Specified Resistance Value Tables.
9. Install the remaining screws consistently from one side of the connection to the other, each time stopping when the fastener head lightly contacts the steel plate.

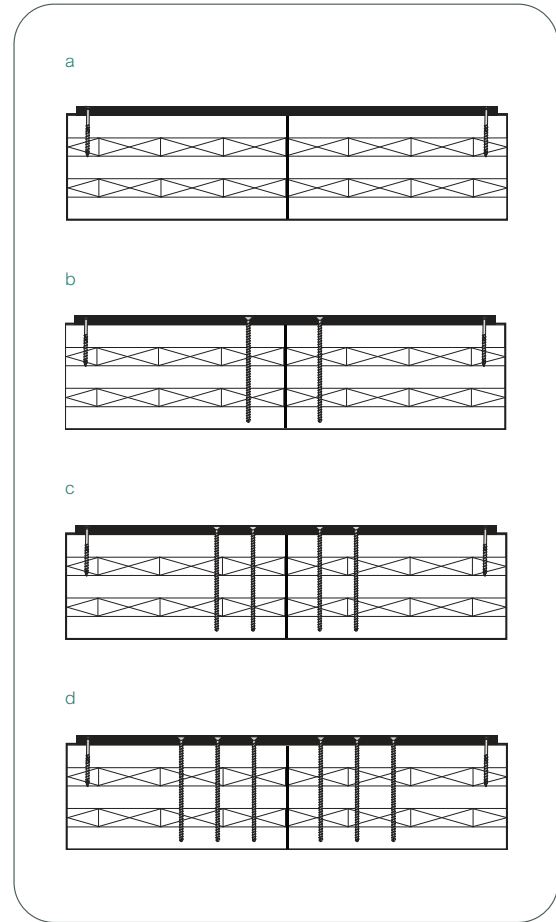

Notes to the Design Engineer

- a) Steel plate detailing should accommodate commonly available locator screws by incorporating suitable holes in the top left and bottom right, especially in end grain connections where the grain orientation can cause fastener deviation during steel plate installation.
- b) Extra holes (~10% of the total required) should be specified for large steel-to-wood tension connections to account for potential installation errors (e.g., accidental damage to screws).

MTC Solutions provides sustainable, high-quality mass timber connection solutions to a rapidly evolving and thriving industry. We drive innovation through certified research and development, while contributing to the education of young talent and experienced professionals in the technology used in sustainable design.





MYC
SOLUTIONS

info@mtcsolutions.com

1.866.899.4090

mtcsolutions.com

