

Version U.S. 3.0

Structural Screw Catalog

ASD & LRFD Design for the United States

info@mtcsolutions.com

1.866.899.4090



Disclaimer

The information in this document is provided on an “as is” basis and for general information purposes only. While MTC Solutions aims to keep the information provided in this document complete, accurate, and in line with state-of-the-art design methods, MTC Solutions, its affiliates, employees, agents, or licensors do not make any representations or warranties of any kind, including, but not limited to, express or implied warranties of fitness for a particular purpose or regarding the content or information in this document, to the full extent permitted by applicable law.

The information in this document does not constitute engineering or other professional advice, and any reliance users place on such information is therefore strictly at their own risk. Images and drawings provided within this document are for reference only and may not apply to all possible conditions. MTC Solutions shall not be liable for any loss or damage of any kind, including indirect, direct, incidental, punitive, or consequential loss or damage arising out of, or in connection with, the information, content, materials referenced, or the use of any of the systems described in this document. Users may derive other applications which are beyond MTC Solutions’ control. The inclusion of the systems or the implied use of this document for other applications is beyond the scope of MTC Solutions’ responsibility.



Structural Screw Catalog

ASD & LRFD Design for the United States



Table of Contents

GENERAL NOTES TO THE DESIGNER	10
Values Determined by Testing.....	12
GENERAL NOTES TO THE INSTALLER	13
FASTENER DURABILITY	15
Fastener Steel and Coatings	16
CONNECTION CLASSIFICATION	17
Axial Connections	17
Lateral Connections	19
FORMULA SUMMARY	21
Adjusted Withdrawal Design Value of the Fastener, W'	21
Adjusted Head Pull-Through Design Value of the Fastener, W'_H	22
Tensile Strength of the Fastener, T'_s	22
Shear Strength of the Fastener, V'	22
Adjusted Buckling Design Value of the Fastener, W'_C	23
Adjusted Lateral Design Value of the Fastener, Z'	23
Tensile Capacity of the Connection, P'_{rt}	24
Compressive Capacity of the Connection, P'_{rc}	24
Connection Capacity Calculation for Combined Loading Scenarios.....	25
Load Combination Check.....	25
MTC STRUCTURAL FASTENER SELECTION PROCESS	26
MTC STRUCTURAL FASTENER OVERVIEW	28
PARTIALLY THREADED 4.0 FASTENER SERIES	31
ASSY Ecofast 4.0.....	32
ASSY SK 4.0.....	34
ASSY Kombi 4.0	37
ASSY Kombi LT 4.0	39
ASSY FWH 4.0	40
Reference Design Values.....	41
Geometry Requirements	43
FULLY THREADED FASTENER SERIES	47
ASSY VG CSK	48
ASSY VG CYL	50
ASSY VG RH.....	52
Reference Design Values.....	54
Geometry Requirements	56
STAINLESS STEEL FASTENER SERIES	59
ASSY A2 Ecofast	60
ASSY A2 SK.....	61
Reference Design Values.....	62
Geometry Requirements	63

SELF-DRILLING DOWELS	65
Self-Drilling Dowel.....	66
Specified Strength Values.....	66
Geometry Requirements.....	67
ACCESSORIES	69
90° Cup Washer.....	69
45° Wedge Washer.....	70
Predrilling Jig.....	71
Bits.....	71
Magnetic Hex Socket.....	72
Bit Holder Socket.....	72
Reverse-Head Socket.....	72
Magnetic Bit Case Holder VG RH.....	73
Magnetic Bit Case Holder SK, VG CSK.....	73
APPENDIX	75
Appendix A: General Connection Information.....	76
Appendix B: Additional Geometry Considerations.....	79
Appendix C: Steel Plate Detailing.....	84
Appendix D: Service Conditions and Durable Design.....	86
Appendix E: Installation Guidelines.....	95

Mass Timber Hardware Specialists



At MTC Solutions, our core focus is to supply structural hardware for modern mass timber applications in commercial, industrial, and residential projects. Our pride lies in collaborating with leading industry experts to offer design solutions and tools for code-compliant, sustainable buildings, continuously pushing the boundaries of the North American construction industry.

Our in-house team of mass timber specialists support professionals in designing customized connections that cater to the specific requirements of each project, resulting in truly innovative and cost-efficient solutions. With industry-recognized expertise and tested & proven solutions, we stand at the forefront of the industry, driving progress and innovation in mass timber construction.



Expertise

We provide our customers with the knowledge and tools necessary to construct cutting-edge, code-compliant mass timber projects while pushing the boundaries of the North American construction industry.



Commitment

We are dedicated to making your project a success, offering support from design and installation assistance to fast and precise delivery of high-quality products.



Products Tailored for North America

We partner with leading research facilities across North America to ensure that our products are tested and customized to meet the unique needs of the market, including seismic considerations and solutions for large post-and-beam structures in various climates.

Find Your Connection Solution

MTC Solutions provides the right tools to design code-compliant buildings, educating the mass timber industry on connection solutions.

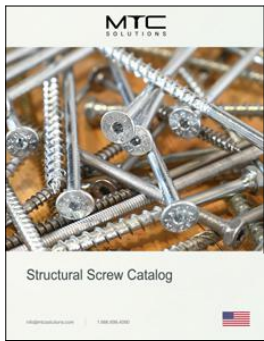

Structural Screw Catalog



Structural Screw Connection Design Guide



Structural Fasteners



Accessories

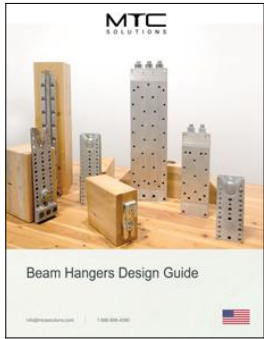

Beam Hangers Design Guide



Beam Hangers



Connector Design Guide



Connectors



Rigging Design Guide



Rigging Devices

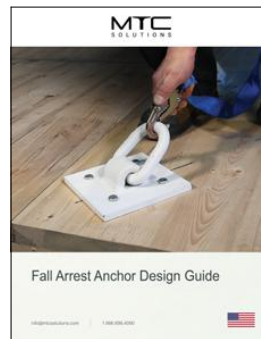

Fall Arrest Anchor Design Guide



Fall Arrest



**WHO
ARE WE?**

YOUR MASS TIMBER HARDWARE SUPPLIER

Rely on our distribution team to deliver your North American projects with speed and accuracy.

LEADING WITH INNOVATION & RESEARCH

We are leading the mass timber industry with cutting-edge connection solutions and through partnerships with renowned research facilities.

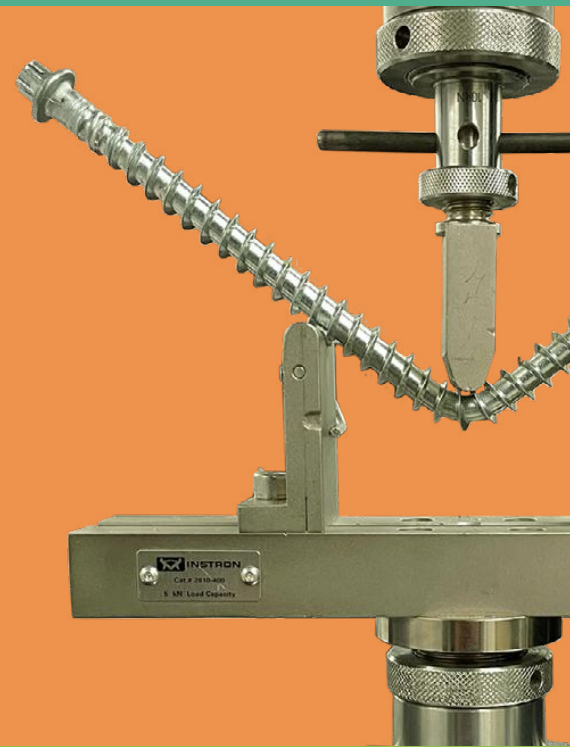

WE MAKE YOU THE EXPERT

Learn about the right solutions for your projects and mass timber connections with our technical resources & support team!

CONNECTIONS DESIGN SUPPORT

Reach out to the technical team for design support, from early design stages to ongoing iterative changes. We help find the most efficient connection solutions.

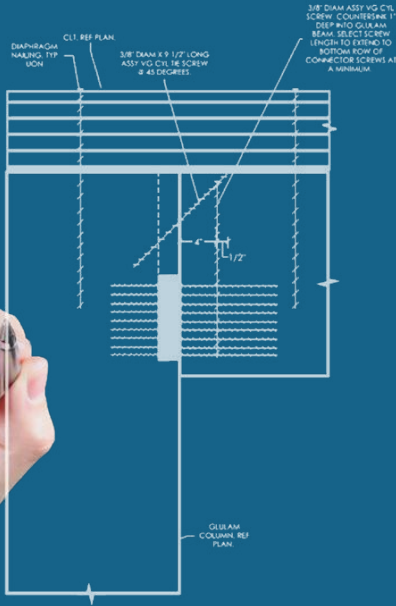

MANUFACTURERS' HELP DESK

Use our comprehensive & practical resources to find the most cost-effective solutions for your structural elements.



TESTED & PROVEN SOLUTIONS

Count on MTC Solutions' 10+ years of expertise, providing tested & proven ICC-ES-certified solutions, support, and resources.



General Notes to the Designer

- All suggestions and details provided are general guidelines and cannot be assumed to be valid for all construction requirements and specific site conditions.
- Reference design values presented herein are based on NDS 2024, ICC-ESR-3178 (2024), ICC-ESR-3719 (2024), and boundary conditions outlined in ETA-11/0190, unless otherwise noted.
- Reference design values must be adjusted in accordance with all applicable adjustment factors of NDS 2024, as outlined in Sections 11.3 and 12.5. The correct adjustment factors for Allowable Stress Design (ASD) and Load and Resistance Factor Design (LRFD) must be applied, and these two methods cannot be interchanged.
- A load-bearing connection shall consist of at least two fasteners.
- Reference design values presented in this guide assume connections will not experience sustained exposure to temperatures above 100°F. For other conditions, reference design values must be multiplied by the appropriate temperature factor, C_t , per NDS 2024 Table 11.3.4.
- The load duration factor, C_D , does not apply to connections where capacity is controlled by metal or concrete/masonry strength.
- Connections must respect the geometry requirements as specified in the respective detailing section for each series of fasteners.
- For connections with multiple closely spaced fasteners, their capacity may be limited by the capacity of the surrounding wood. Applying the minimum geometry requirements does not prevent wood failure such as row tear-out, group tear-out, block tear-out, net tension failure, or splitting perpendicular to grain caused by local stresses. These failures should be checked based on the principles of engineering mechanics in accordance with NDS 2024 Section 11.1.2. Additionally, refer to Appendix A: General Connection Information (Page 76) for further information on brittle failure modes in wood.
- The designer must ensure that all possible stress limits in the wood members, such as the shear capacity, the rolling shear capacity of the cross-laminated timber (CLT), or other material properties, are not exceeded while maintaining a continuous load path.
- In wood species sensitive to splitting, the minimum geometry requirements may need to be increased to minimize the risk of splitting.
- Different series of fasteners vary in tensile strength, T_s , shear strength, V , and bending yield strength, F_{yb} . These different fastener properties must be considered in the design, as they can influence the total lateral or axial capacity of a connection.
- For a connection with multiple fasteners, only the capacities of the fasteners of the same diameter and exhibiting the same yield mode or governed by the same failure mode may be added together to obtain the total capacity of the connection. For example, the withdrawal capacity of a fastener cannot be added to the tensile capacity of a fastener to obtain the total capacity of a connection.
- For a connection with inclined axially loaded screws, the listed reference design values are given along the line of force. The vector has already been projected from each screw's axis to the shear plane of the connection.
- Where steel side plate members are used, ASTM A36 rolled plate with $F_u \geq 58,000$ psi is required at minimum.



15. Dowel bearing strength, F_e , for ASTM A36 steel side plates is 87,000 psi per NDS 2024.
16. Dowel bearing strength, F_e , for fasteners with a shank diameter of D_s installed in wood members is calculated as follows:
 - For $D_s < 1/4$ in., $F_e = 16,600 \cdot G^{1.84}$ psi
 - For fasteners with $D_s \geq 1/4$ in. loaded parallel to grain, $F_{e\parallel} = 11,200 \cdot G$ psi
 - For fasteners with $D_s \geq 1/4$ in. loaded perpendicular to grain, $F_{e\perp} = 6,100 \cdot G^{1.45}/\sqrt{D_s}$ psi
17. Dowel bearing strength, F_e , for fasteners with a shank diameter of D_s installed in narrow edge of CLT panels is calculated as follows:
 - For $D_s < 1/4$ in., $F_e = F_e$
 - For $D_s \geq 1/4$ in., $F_e = F_{e\perp}$
18. Dowel bearing strength, F_e , for fasteners with a shank diameter of D_s installed in wood structural panels is calculated as follows:
 - For plywood and $D_s \leq 1/4$ in.,
 - $F_e = 4,650$ psi for Structural 1 and Marine ($G = 0.5$) grades
 - $F_e = 3,350$ psi for other grades ($G = 0.42$)
 - For plywood of all grades ($G = 0.5$) and $D_s > 1/4$ in., $F_e = 5,600$ psi
 - For OSB of all grades ($G = 0.5$) and $D_s \leq 1/4$ in., $F_e = 4,650$ psi
19. The minimum member thickness, t , of lumber and timber members varies with the nominal fastener diameter, D , as follows:
 - For screws with $D = 1/4$ in., $t \geq 15/16$ in.
 - For screws with $D = 5/16$ in., $t \geq 1-3/16$ in.
 - For screws with $D = 3/8$ in., $t \geq 1-9/16$ in.
 - For screws with $D = 1/2$ in., $t \geq 3-5/32$ in.
 - For screws with $D = 9/16$ in., $t \geq 3-15/16$ in.
20. The minimum member thickness, t , of structural wood panels, such as plywood or OSB, varies with the nominal fastener diameter, D , as follows:
 - For screws with $D = 1/4$ in., $t \geq 1/2$ in.
 - For screws with $D = 5/16$ in., $t \geq 5/8$ in.
 - For screws with $D = 3/8$ in., $t \geq 3/4$ in.
 - For screws with $D = 1/2$ in., $t \geq 1$ in.
 - For screws with $D = 9/16$ in., $t \geq 1-1/8$ in.
21. Pilot holes are recommended for the following conditions to reduce the risk of splitting when installing fasteners with nominal diameter of D :
 - For species prone to splitting, including various species of spruce and fir, including Douglas Fir.
 - For lumber with thickness $\leq 1-1/2$ in.
 - For laterally loaded screws installed in lumber with a thickness $\leq 7D$ ($\leq 14D$ for various species of spruce and fir, including Douglas Fir).
 - For axially loaded screws installed in lumber with a thickness $\leq 10D$ and/or a width of less than $8D$ or $2-3/8$ in., whichever is greater.
22. The minimum penetration length of a fastener (excluding the tip, equivalent to D) with a nominal diameter, D , in the main member shall be:
 - $5D$ when loaded in shear
 - $4D$ when axially loaded and installed in side grain
 - $20D$ when axially loaded in end grain
23. To ensure full connection resistance in CLT panels, it is recommended that fasteners penetrate panel plies to the largest extent possible.
24. For specific gravities assigned to different timber species, refer to NDS 2024 Table 12.3.3A.
25. Predrilling is recommended for installation of fasteners into dry ($< 10\%$ moisture content) Southern Yellow Pine (SYP) to reduce installation torque.

- 
26. A hole is considered to be predrilled if its length matches the entire length of the fastener. Refer to Appendix E: Installation Guidelines (Page 95) for more information on predrilling and pilot holes.
 27. The designer must consider corrosion resistance, service conditions, and the connection environment when specifying fasteners. See the Fastener Durability section (Page 15) and Appendix D: Service Conditions and Durable Design (Page 86) for additional information.
 28. MTC Solutions carbon steel fasteners have a core hardness of less than 390 HV, making them suitable for dry service conditions only (see NDS 2024 Clause 11.3.3). For wet service conditions, use MTC Solutions stainless steel fasteners. Refer to the Fastener Durability section (Page 15) and Appendix D: Service Conditions and Durable Design (Page 86) for additional information.
 29. During construction, mass timber elements may experience temporary surface wetting, potentially causing the timber surface moisture content (MC) to exceed 19%. In such cases, A3K electroplated carbon steel fasteners are acceptable for use, provided that the following three conditions are met. First, the surface wetting shall not exceed the moisture limits defined for dry service conditions for more than a few weeks per year. Second, the annual average MC during construction shall remain within the range of 10–16%. Third, the design must incorporate appropriate detailing to accommodate dimensional changes in the wood due to wetting and/or drying. If any of these conditions cannot be met, fasteners with enhanced corrosion resistance are recommended, and detailing must be adjusted accordingly.

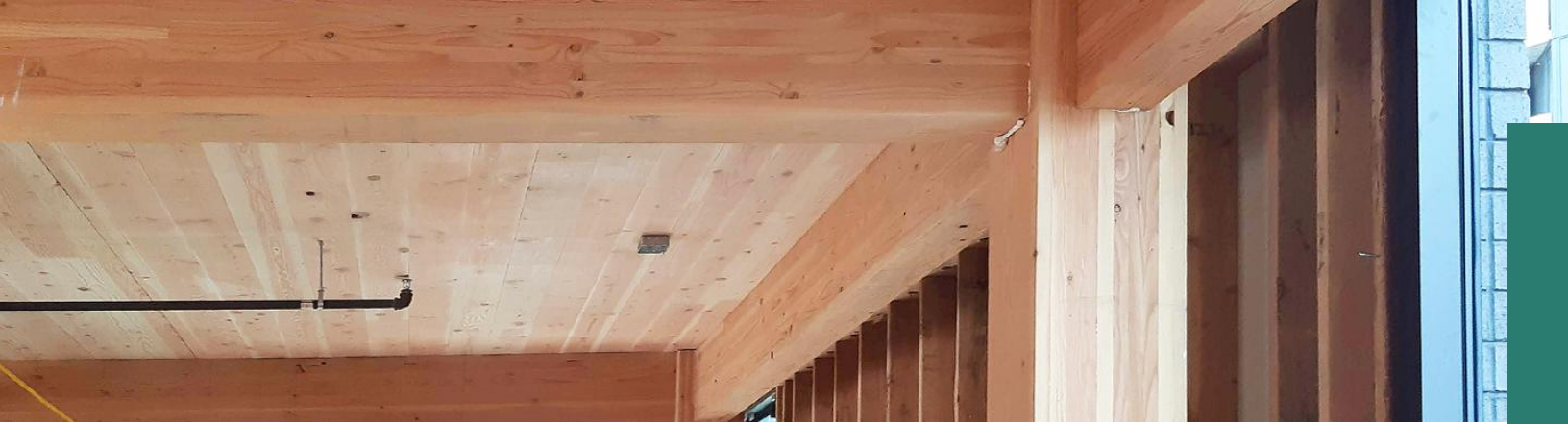

General Notes to the Installer

1. All the specified fasteners should be installed prior to loading the members.
2. Carbon steel fasteners shall only be used in dry service conditions, as exposure to wet service conditions may lead to premature failure. Refer to the Fastener Durability section (Page 15) and Appendix D: Service Conditions and Durable Design (Page 86) for additional information.
3. During construction, mass timber elements may experience temporary surface wetting, potentially causing the timber surface moisture content (MC) to exceed 19%. In such cases, A3K electroplated carbon steel fasteners are acceptable for use, provided that the following three conditions are met. First, the surface wetting shall not exceed the moisture limits defined for dry service conditions for more than a few weeks per year. Second, the annual average MC during construction shall remain within the range of 10–16%. Third, the design must incorporate appropriate detailing to accommodate dimensional changes in the wood due to wetting and/or drying. If any of these conditions cannot be met, fasteners with enhanced corrosion resistance are recommended, and detailing must be adjusted accordingly.
4. Connections designed for dry service conditions should be protected from excessive moisture during construction and in service.
5. Fully threaded fasteners shall not be used in green wood (MC > 19%) to reduce the potential for wood splitting.
6. Different types of fasteners vary in strength and corrosion resistance. Installers should avoid substituting one type of fastener for another without consulting a licensed design professional.
7. Use a drill equipped with a feather (variable-speed) trigger to ensure proper torque management and mitigate the risk of overtorquing. Although impact guns are not expressly prohibited, their use is discouraged—particularly in steel-to-wood connections—due to increased risk of overtorquing. If an impact gun is utilized, limit its use to fasteners short screws and maintain a continuous drive without pausing. For more information on drill selection, refer to Appendix E: Installation Guidelines (Page 95).
8. If splitting of a wood member or fastener breakage is observed during or prior to fastener installation, the installation process must be stopped, a licensed design professional contacted immediately, and appropriate measures taken.
9. Unless indicated by the designer, do not overdrive the fasteners, as this may reduce connection resistance.
10. To avoid increased torque peaks caused by stopping and restarting during the drive-in process, a screw should be fully driven in an uninterrupted process until the head is lightly seated against the side member. If necessary, a torque wrench may be used to complete installation immediately after the initial insertion of the screw.
11. The maximum allowable insertion torque of the fasteners must be respected. Refer to the Fastener Strength Value tables for allowable values.
12. Predrilling will help reduce the insertion torque for self-tapping screws.
13. Predrilling may also be required in cases involving unusually dry wood, dense wood, aged timber, end-grain and near-edge installation, and large-diameter fasteners. For more information on predrilling refer to Appendix E: Installation Guidelines (Page 95).

- 
14. A hole is considered to be predrilled if its length matches the entire length of the fastener. Refer to Appendix E: Installation Guidelines (Page 95) for more information on predrilling and pilot holes.
15. Predrilling is recommended for installation of fasteners into dry ($< 10\%$ MC) Southern Yellow Pine (SYP) to reduce installation torque.
16. Pilot holes may be used to facilitate the installation of long self-tapping screws or when fasteners are being installed at an angle, near an edge, or in the end grain. Pilot holes should be at least 1 in. deep to facilitate installation depending on the connection configuration. The pilot hole diameter must not exceed the minor diameter, D_m , of the fastener. For more information on pilot holes, refer to Appendix E: Installation Guidelines (Page 95).
17. Pilot holes are recommended for the following conditions to reduce the risk of splitting:
- For species prone to splitting, including various species of spruce and fir, including Douglas Fir.
 - For lumber with thickness $\leq 1\text{-}1/2$ in.
 - For laterally loaded screws installed in lumber with a thickness $\leq 7D$ ($\leq 14D$ for various species of spruce and fir, including Douglas Fir).
 - For axially loaded screws installed in lumber with a thickness $\leq 10D$ and/or a width of less than $8D$ or $2\text{-}3/8$ in., whichever is greater.

Fastener Durability

This section offers suggestions to help designers choose the most durable fasteners for various service conditions. These guidelines are not exhaustive, and site-specific conditions may warrant differing levels of protection. Additionally, these recommendations should be validated by a licensed design professional based on the anticipated exposure during the lifespan of the connection. Carbon steel screws with a core hardness above 360 HV are not advisable for use in wet service in alignment with industry best practices. MTC carbon steel fasteners have a core hardness between 360 HV and 390 HV, and therefore shall only be used in dry service conditions.

Fasteners supplied by MTC Solutions meet ISO 2702 standard during the manufacturing process and have a hardness less than 390 HV in order to mitigate Internal Hydrogen Embrittlement (IHE). In addition, MTC Solutions utilizes post-manufacturing inspection techniques in accordance with ISO 4042 and ISO 15330 to verify our fasteners meet these hardness requirements, which further mitigates the risk of a brittle HE failure.

Designers should consider service conditions and the associated demands for corrosion resistance, structural capacity, accessibility for periodic inspections, ease of fastener replacement, and cost when specifying fasteners. Improper material selection can negatively impact fastener strength and durability, leading to corrosion. For further details, refer to the additional information provided in Appendix D: Service Conditions and Durable Design (Page 86).

1.1 - Suggested Corrosion Resistance for Common Service Conditions

Service Conditions	Environment	Suggested Corrosion Resistance
Dry	Untreated Wood	Regular
	Preservative-treated Wood	Regular or High
	Fire Retardant-treated Wood	Regular or High
Wet	Untreated Wood	High
	Preservative-treated Wood	High
Increased Corrosion Risks	Marine / Salt Water Exposure	Extreme
	Exposure to Aggressive Chemicals	Extreme

Notes:

1. The corrosion resistance of the fastener must account for the interactions between moisture and specific treatment chemicals.
2. See the Fastener Steel and Coatings section on the following page for information on the corresponding types of fasteners available at MTC Solutions.

Fastener Steel and Coatings

MTC Solutions offers fasteners in three different types of steel and coating to accommodate different corrosion resistance requirements.

Regular Corrosion-Resistant Fasteners

Carbon Steel with Blue Passivated Zinc Surface Coating—A3K

Regular corrosion-resistant fasteners are fabricated from case-hardened carbon steel with a maximum core hardness of 390 HV in accordance with industry best practices. The blue passivated zinc alloy coating (8–12 microns in thickness) on high-performance carbon steel fasteners contains zinc and nickel, delivering standard corrosion protection. The electroplated surface coating is categorized as A3K and utilizes CrIII passivation in accordance with DIN EN ISO 4042 (which specifies the requirements for electroplated coatings and coating systems on steel fasteners) which corresponds to ISO4042/Zn8/An/T4. These fasteners are adequate for use in low-corrosive environments, such as dry service conditions.



High Corrosion-Resistant Fasteners

A2 Stainless Steel

A2 is a European designation for chromium–nickel austenitic stainless steel (corrosion resistant) with low carbon content and a copper addition. This grade is generally equivalent to Type 304 stainless steel in North America. As stainless steel is a softer metal than carbon steel, A2 stainless steel screws exhibit lower strengths compared to carbon steel screws, which must be accounted for in design. Predrilling may also be required for longer A2 stainless steel screws. These screws are adequate for use in corrosive environments, such as those involving wet service conditions in certain types of treated lumber.

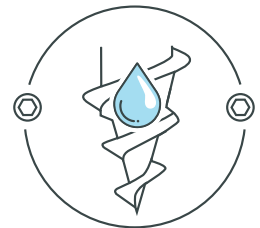

Extreme Corrosion-Resistant Fasteners

A4 Stainless Steel (Custom Order)

A4 is another European designation for chromium–nickel austenitic stainless steel (corrosion resistant) with low carbon content and a copper addition. This grade generally corresponds to Type 316 stainless steel in North America. A4 fasteners are adequate for use in more corrosive environments, such as those involving wet service conditions with the presence of salt water or other scenarios with increased corrosion risks.



MTC Solutions only supplies A4 stainless steel fasteners through custom orders. Clients are therefore advised to factor in an adequate lead time for their orders.

Connection Classification

Axial Connections

Connections with fasteners loaded axially in tension

These connections transfer axial tensile loads between side and main members with fasteners loaded axially in tension along their axis. Axial connections are typically designed for withdrawal and head pull-through in the wood members, as well as the tensile strength of the fasteners. The tensile capacity, P'_{rt} , of these connections is then taken as the minimum of:

- (a) W' adjusted withdrawal design value of the fastener in the main member (i.e., the member containing the fastener tip) **eq. 1 (Page 21)**
- (b) T'_s adjusted tensile strength of the fastener, and **eq. 3 (Page 22)**
- (c) the greater of:
 - (i) W' adjusted withdrawal design value of the fastener in the side member, and **eq. 1 (Page 21)**
 - (ii) W'_H adjusted head-pull through design value of the fastener **eq. 2 (Page 22)**

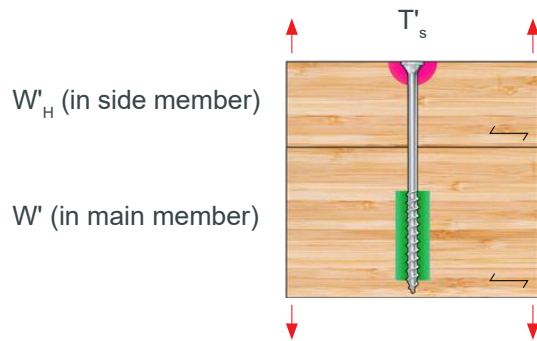

Partially Threaded Fastener in Axial Tension

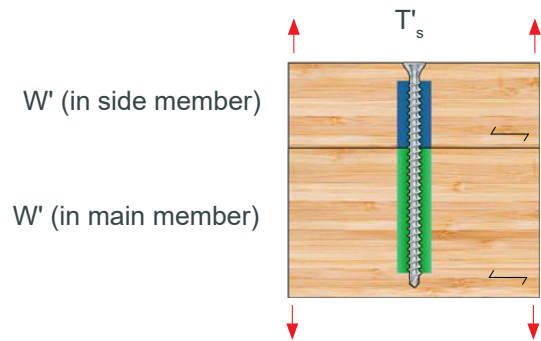

Fully Threaded Fastener in Axial Tension

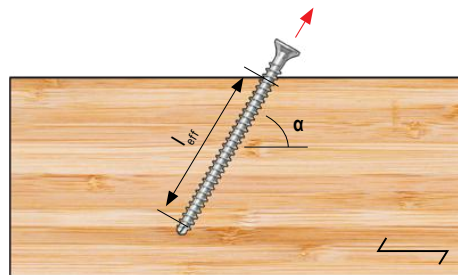

Withdrawal at an Angle of α to the Grain

Notes:

1. Where steel plate side members are used, the steel plate hole must be the correct size and the thickness of the steel plate shall be taken in consideration to ensure proper bearing of the fastener head.
2. Connections should meet requirements provided in the General Notes to the Designer section.
3. The examples represent single-fastener connections. However, in practice, all connections shall consist of at least two fasteners.
4. The tip of the fastener (equal to D in length) must be excluded from the effective length when calculating the withdrawal capacity of the fastener.

Connections with fasteners loaded axially in compression

These connections transfer axial compressive loads between side and main members with fasteners loaded axially in compression along their axis. A fastener is considered in withdrawal when it is pushed into the wood member under axial compression, just as it is when pulled out of the wood member under axial tension. When a fastener is loaded axially in compression, its compressive capacity, P'_{rc} , is calculated as the minimum of:

- (a) W' adjusted withdrawal design value of the fastener, and **eq. 1 (Page 21)**
- (b) W'_c adjusted buckling design value of the fastener **eq. 5 (Page 23)**

For bearing reinforcement, the buckling resistance of screws is alternatively permitted to be determined by testing, which often yields higher design values than calculated results. Buckling design values for fully threaded fasteners are provided in Table 3.3 (Page 54).



Lateral Connections

Lateral connections with fasteners loaded in shear

These connections transfer lateral loads between side and main members with fasteners loaded in shear perpendicular to their axis. Lateral connections may offer ductile behavior if designed properly. Refer to Appendix A: General Connection Information (Page 76) for further information. The adjusted lateral capacity of the connection, Z'_r , is governed by the provisions in NDS 2024 Section 12.3, and is calculated as the minimum of:

- (a) Z' adjusted lateral design value of the fastener, **eq. 6 (Page 23)**
- (b) V' adjusted shear strength of the fastener, and **eq. 4 (Page 22)**
- (c) Z'_r adjusted design value of the wood member for brittle failure modes **NDS 2024 Section 11.1.2**



Lateral Connection with a Fastener Loaded in Shear

Lateral connections with axially loaded inclined fasteners in tension

These connections transfer lateral loads between side and main members with fasteners loaded axially in tension at an angle to the wood fiber grain, α . Fasteners can be inclined at an angle relative to the shear plane, β , that ranges from 30° to 60° . Typically, fasteners are angled at 45° for these connections. Fasteners should be inclined to ensure the fasteners are loaded in tension only, and the connection should not be subjected to reverse loading. These connections with inclined fasteners are typically stiffer than connections with fasteners loaded in shear.

The adjusted lateral capacity of the connection, Z'_r , is calculated as the minimum of:

- (a) $P'_{rt} \cdot \cos\beta$ product of the adjusted tensile capacity of the connection and $\cos\beta$, and **eq. 7 (Page 24)**
- (b) Z'_r adjusted design value of the wood member for brittle failure modes **NDS 2024 section 11.1.2**

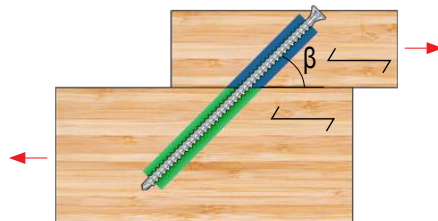

Lateral Connection with an Axially Loaded Inclined Screw

Lateral connections with axially loaded inclined fasteners in cross pairs

These connections transfer lateral loads between side and main members with pairs of fasteners installed at equal angles to the wood fiber grain in a cross configuration. Fasteners can be inclined at an angle relative to the shear plane, β , that ranges from 30° to 60° . Typically, fasteners are angled at 45° for these connections. This configuration is useful for bidirectional reverse loading. To be considered a cross pair, the fasteners should be installed at matching angles relative to the shear plane and have equal penetration. The point of intersection between the screw planes should occur within the length of the fastener. The fasteners ideally should cross at either the centroid of the side member or, alternatively, at the shear plane. The adjusted lateral capacity of the connection, Z' , requires evaluating the:

- (a) V' adjusted shear strength of the fastener **eq. 4 (Page 22)**
- (b) P'_{rt} adjusted tensile capacity of the connection **eq. 7 (Page 24)**
- (c) P'_{rc} adjusted compressive capacity of the connection **eq. 8 (Page 24)**

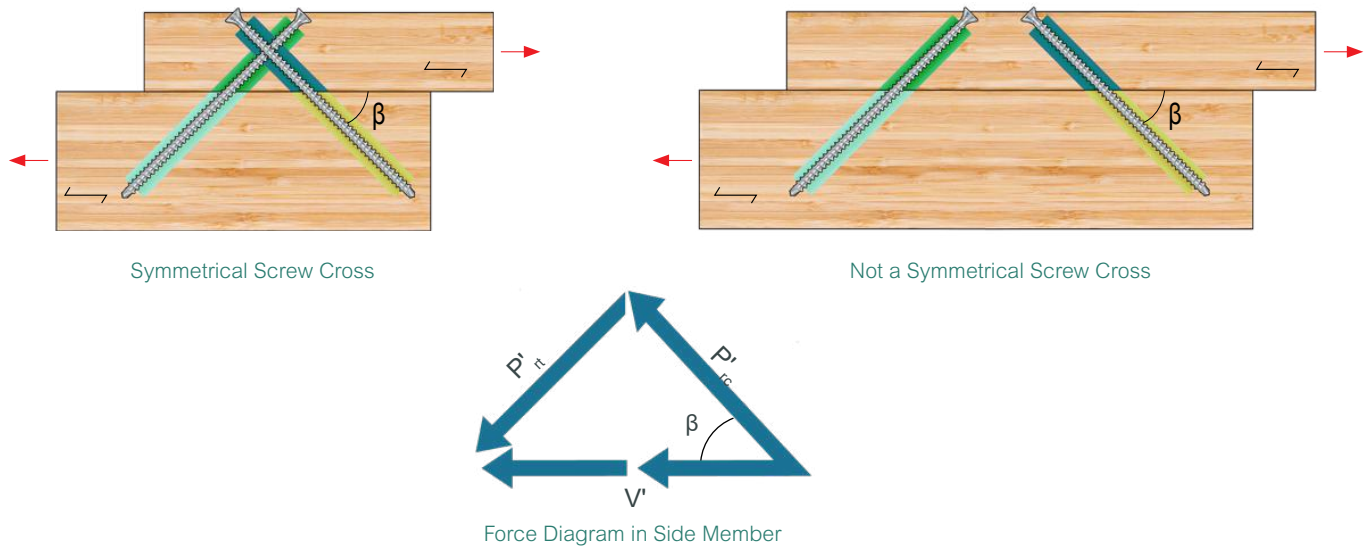

The connection capacity should not be determined by summing the factored tension and compression resistance, P'_{rt} and P'_{rc} , respectively, but rather it should be limited to the minimum of:

- (a) $2 \cdot P'_{rt} \cdot \cos\beta$ twice the product of the adjusted tensile capacity of the connection and $\cos\beta$, **eq. 7 (Page 24)**
- (b) $2 \cdot P'_{rc} \cdot \cos\beta$ twice the adjusted compressive capacity of the connection and $\cos\beta$, and **eq. 8 (Page 24)**
- (c) $2 \cdot V' / \sin\beta$ twice the adjusted shear strength of the fastener divided by $\sin\beta$ **eq. 4 (Page 22)**

Connections under combined lateral and withdrawal loading

For connections with fasteners perpendicular to the shear plane subjected to a combination of lateral and withdrawal loading, the provisions of NDS 2024 Section 12.4.1 shall be satisfied.

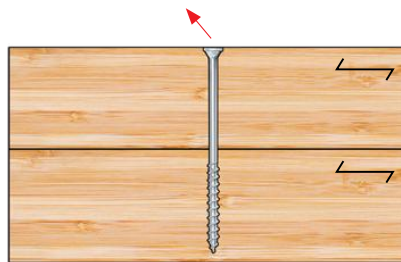

Connection Subjected to Combined Loading

Formula Summary

Adjusted Withdrawal Design Value of the Fastener, W'

Withdrawal strength is proportional to the thread penetration into the wood member. The adjusted withdrawal resistance of a single fastener in a connection is calculated as:

$$W' = W_{90} \cdot l_{eff} \cdot R_{\alpha} \cdot K_{\beta_v} \cdot C' \quad (\text{eq. 1})$$

W_{90} reference perpendicular-to-grain withdrawal design value, provided in Tables 2.1, 3.1, 4.1 and 5.1

l_{eff} effective thread penetration length in the wood member where withdrawal is being calculated (note that the length of the fastener tip ($L_{Tip} = D$) should not be included)

R_{α} angle-to-grain reduction factor in withdrawal application, see Table 1.1

α angle between the fastener axis and the wood fiber grain orientation

K_{β_v} reduction factor for laminated veneer products, see Table 1.2

β_v angle between the screw axis and the wide face of the laminated veneer product

C' applicable adjustment factors according to NDS 2024 Section 11.3 for the connection:

- for ASD : C_D, C_M, C_t, C_{eg}
- for LRFD : $C_M, C_t, C_{eg}, K_F, \Phi, \lambda$

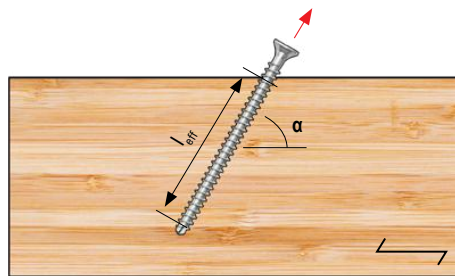

Withdrawal at an Angle of α to the Grain

1.2 - Angle-to-Grain Reduction Factor, R_{α} , for Withdrawal at an Angle of α

α	90°	85°	80°	75°	70°	65°	60°	55°	50°	45°	40°	35°	30°	25°	20°	15°	14°	10°	5°	0°
R_{α} for Timber Products	1.000	1.000	0.990	0.990	0.980	0.970	0.950	0.940	0.920	0.910	0.890	0.840	0.770	0.750	0.750	0.750	0.750	0.750	0.075	0.750
R_{α} for LVL, MPP, Plywood	1.000	0.997	0.990	0.978	0.962	0.944	0.923	0.901	0.879	0.857	0.836	0.817	0.800	0.500	0.500	0.500	0.500	0.500	0.500	0.500

Notes:

1. Timber products in this table refer to members made of lumber, timber, glulam and/or CLT.
2. For $\alpha < 15^\circ$, a minimum of four screws are required for the connection.
3. For $\alpha < 30^\circ$, the connection can only be subjected to short-term loading.
4. Timber product values for $\alpha \geq 30^\circ$ are specified in ICC-ESR-3178 (2024). Remaining values were derived according to the methods described in the ETA-11/0190 for self-tapping wood screws.

1.3 - Reduction Factor for Withdrawal, K_{β_v} , in Laminated Veneer Products at an Angle of β_v to the Wide Face

β_v	90°	85°	80°	75°	70°	65°	60°	55°	50°	45°	40°	35°	30°	25°	20°	15°	10°	5°	0°
K_{β_v}	1	0.996	0.985	0.968	0.945	0.918	0.889	0.859	0.829	0.800	0.773	0.749	0.727	0.709	0.694	0.682	0.673	0.668	0.667

Notes:

1. K_{β_v} is specified in the in ETA-11/0190 (2018) as K_p .
2. Reduction factor, K_{β_v} , accounts for end grain effects in laminated veneer products. Therefore, $C_{eg} = 1$ for laminated veneer products.
3. For lumber, timber, glulam and CLT products, $K_{\beta_v} = 1$.
4. Laminated veneer products include LVL, MPP, and plywood.

Adjusted Head Pull-Through Design Value of the Fastener, W'_H

Head pull-through capacity is a function of the shape and size of the fastener head and may govern where partially threaded fasteners are used in tension. The adjusted head pull-through resistance of a single fastener in a connection is calculated as:

$$W'_H = W_H \cdot C' \quad (\text{eq. 2})$$

W_H reference head pull-through resistance design value, provided in Tables 2.2, 3.2, 4.2 and 5.2

C' applicable adjustment factors according to NDS 2024 Section 11.3 for the connection:

- for ASD: C_D, C_M, C_t
- for LRFD: $C_M, C_t, K_F, \Phi, \lambda$

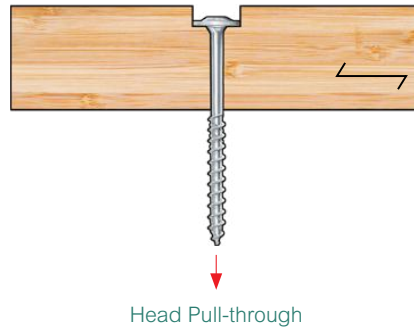

Adjusted Tensile Strength of the Fastener, T'_s

Connection strength may be governed by tension failure of the fastener under axial tension loading. The tensile strength of a single fastener is calculated as:

$$T'_s = T_s \quad (\text{eq. 3})$$

T_s fastener tensile strength value, see reference design value Tables 2.3, 3.3, 4.4, and 5.3

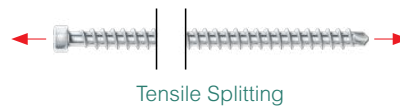

Note:

1. Tensile resistance of the screw shall not be multiplied by adjustment factors per NDS 2024 Section 11.2.3.

Adjusted Shear Strength of the Fastener, V'

Fasteners may fail in shear when subjected to lateral loading. The shear strength of a fastener is calculated as:

$$V' = V \quad (\text{eq. 4})$$

V fastener shear strength value, see reference design values in Tables 2.3, 3.3, 4.4, and 5.3



Note:

1. Shear resistance of the screw shall not be multiplied by adjustment factors per NDS 2024 Section 11.2.3.

Adjusted Buckling Design Value of the Fastener, W'_c

Under axial compression loading, when a fastener is pushed into the wood member, this is considered the same as withdrawal resistance. If the withdrawal resistance in the wood member is high under axial compressive loading, the fastener may buckle. The adjusted buckling resistance of a single fastener is calculated as:

$$W'_c = W_c \cdot C' \quad (\text{eq. 5})$$

W_c reference buckling resistance design value, provided in Table 3.3

C' applicable adjustment factors according to NDS 2024 Section 11.3 for the connection:

- for ASD: C_D, C_M, C_t, C_{eg}
- for LRFD: $C_M, C_t, C_{eg}, \lambda$



Notes:

1. Load duration factor, C_D , greater than 1.0 shall not apply for calculation of buckling resistance, W'_c , in ASD.
2. Time effect factor, λ , greater than 0.8 shall not apply for calculation of buckling resistance, W'_c , in LRFD.
3. The equation and adjustment factor presented in this section are only valid for reference buckling resistance values presented in Table 3.3 of this guide.
4. LRFD reference buckling resistance values presented in Table 2.3 already include a Φ factor of 0.65.
5. For LRFD adjustment factor, according to NDS 2024 Appendix N.3.1, the format conversion factor, K_F , shall not apply, as the LRFD reference resistances are determined in accordance with the reliability normalization factor method in ASTM D5457.

Adjusted Lateral Design Value of the Fastener, Z'

Lateral capacity is primarily a function of the embedment failure in the wood member, yielding failure of the fastener, or a combination of both. The adjusted lateral design resistance of a single-fastener connection is calculated as:

$$Z' = Z \cdot C' \quad (\text{eq. 6})$$

Z reference lateral design value, calculated using bending yield strength, F_{yb} , values provided in Tables 2.3, 3.3, 4.4, and 5.3, and yield equations provided in NDS 2024 Section 12.3.1

C' applicable adjustment factors according to NDS 2024 Section 11.3 for the connection:

- for ASD: $C_D, C_M, C_t, C_{eg}, C_g$
- for LRFD: $C_M, C_t, C_{eg}, C_g, K_F, \Phi, \lambda$

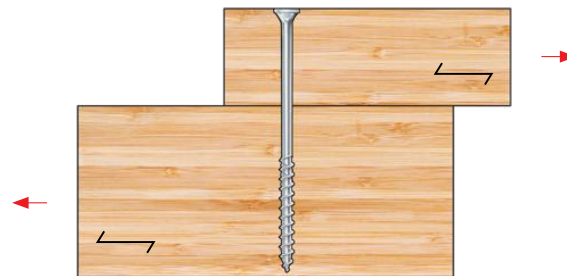

Adjusted Tensile Capacity of the Connection, P'_{rt}

The overall tensile capacity of a connection must consider the withdrawal capacity of the fastener in both the main and side members, the tensile capacity of the fastener, and the head-pull through capacity of the fastener in the side member.

$$P'_{rt} = \text{Minimum of } \begin{cases} W' (main) \\ T'_s \\ \text{Maximum of } \begin{cases} W' (side) \\ W'_H \end{cases} \end{cases} \quad (\text{eq. 7})$$

- W' adjusted withdrawal design value of the fastener
- T'_s tensile strength of the fastener
- W'_H adjusted head-pull through design value of the fastener

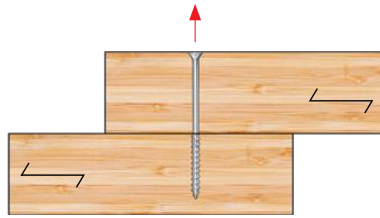

Tensile Connection

Adjusted Compressive Capacity of the Connection, P'_{rc}

The overall compressive capacity of a connection must consider the withdrawal capacity of the fastener in both the main and side members, the tensile capacity of the fastener, and the head-pull through capacity of the fastener in the side member. Note that for bearing reinforcement, there will only be a main member.

$$P'_{rc} = \text{Minimum of } \begin{cases} W' (main) \\ W' (side) \\ W'_c \end{cases} \quad (\text{eq. 8})$$

- W' adjusted withdrawal design value of the fastener
- W'_c adjusted buckling design value of the fastener

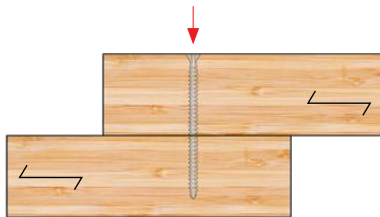

Compression Connection

Connection Capacity Calculation for Combined Loading Scenarios

For connections subjected to a combined lateral and withdrawal loading with the fastener perpendicular to the shear plane, the combined loads connection capacity, $Z'_{r\delta}$, can be calculated according to NDS 2024 Section 12.4.1 as:

$$Z'_{r\delta} = \frac{P'_r \cdot Z'_r}{P'_r \cdot \cos^2 \delta + Z'_r \sin^2 \delta} \quad (\text{eq. 9})$$

P'_r axial capacity of the connection (tension or compression)

Z'_r lateral capacity of the connection

δ angle between wood surface and direction of applied load

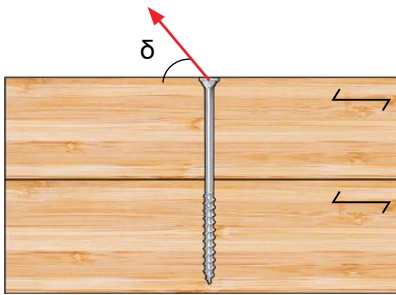

Connection Subjected to Combined Loading

Load Combination Check

A load combination check (NDS 2024 Section 12.4.2-2 Commentary) should be performed for connections subjected to combined loading :

$$\left(\frac{V}{Z'_r}\right) + \left(\frac{T}{P'_r}\right) \leq 1 \quad (\text{eq. 10})$$

V applied lateral force on the connection

T applied tensile force on the connection

Z'_r lateral capacity of the connection

P'_r axial capacity of the connection (tension or compression)

MTC Structural Fastener Selection Process

Ensuring desired connection performance depends on choosing the appropriate screws for the project. Our comprehensive guide below facilitates quick navigation of available options and offers tips to aid selection. Individual project requirements may dictate alternative fasteners. It is advisable to consult with a licensed design professional to ensure the selection of the correct fasteners for the specific application.

Step 1: Fastener Series Selection

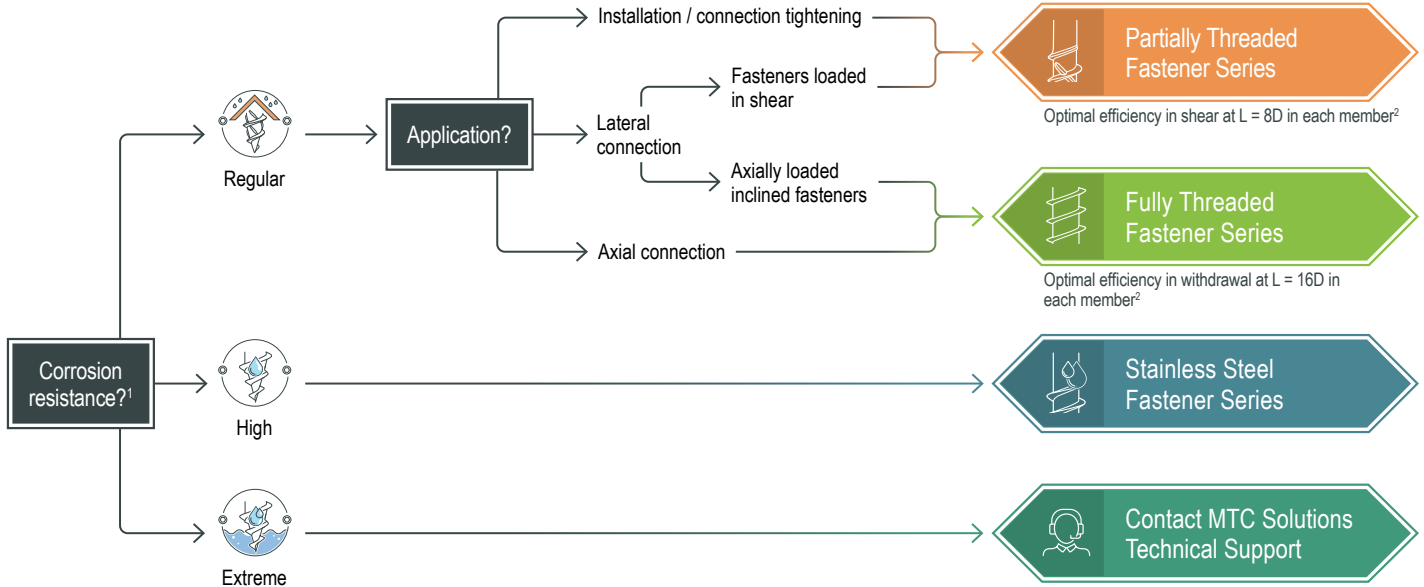

Notes: 1. See Appendix D: Service Conditions and Durable Design (Page 86) for more details on service conditions and corrosion resistance.

2. L and D are the thread penetration length and nominal diameter, respectively. This thread penetration length is only a rule of thumb.

Step 2: Fastener Model Selection¹

Architectural finish
 Best solution for this connection type
 Not ideal
 Best solution for wet service conditions

Fastener Type	Connection Type		Available Diameters					
	Wood-to-Wood	Steel-to-Wood	in. [mm]					
			1/4 [6]	5/16 [8]	3/8 [10]	1/2 [12]	9/16 [14]	
Partially Threaded Fastener Series	Ecofast			✓	✓	✓		
	SK			✓	✓	✓	✓	
	Kombi				✓	✓	✓	
	FWH				✓			
Fully Threaded Fastener Series	VG CSK				✓	✓	✓	
	VG CYL				✓	✓		
	VG RH							✓
Stainless Steel Fastener Series	A2 Ecofast			✓	✓			
	A2 SK			✓	✓			

Notes: 1. The presented selection process serves as guidelines only. The final decision must be made by a licensed design professional.

2. For fasteners loaded in withdrawal, side-member resistance must be designed based on the thread penetration length.



Bayview Elementary School

Vancouver, British Columbia

MTC Structural Fastener Overview

Partially Threaded Fastener Series

Ecofast



Countersunk Head
Carbon Steel
Page 32



SK



Washer Head
Carbon Steel
Page 34



Kombi



Hexagonal Head
Carbon Steel
Page 37



Kombi LT



Hexagonal Head
Carbon Steel
Page 39



FWH



Flat Washer Head
Carbon Steel
Page 40



Fully Threaded Fastener Series

VG CSK



Countersunk Head
Carbon Steel
Page 48



VG CYL



Cylinder Head
Carbon Steel
Page 50



VG RH



Reverse Head
Carbon Steel
Page 52



Stainless Steel Fastener Series

A2 Ecofast



Countersunk Head
Stainless Steel
Page 60



A2 SK



Washer Head
Stainless Steel
Page 61



Self-Drilling Dowel

SDD



Cylinder Head
Carbon Steel
Page 66

Accessories

90° Cup Washer



Page 69

45° Wedge Washer



Page 70

Predrilling Jig



Page 71

Bits



Page 71

Magnetic Hex Socket



Page 72

Bit Holder Socket



Page 72

Reverse Head Socket



Page 72

Magnetic Bit Case Holder VG RH

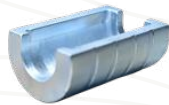

Page 73

Magnetic Bit Case Holder SK, VG CSK



Page 73



Philip J. Currie Dinosaur Museum

Wembley, Alberta

Partially Threaded 4.0 Fastener Series

MTC Solutions self-tapping Partially Threaded fasteners are designed to pull members tightly together, often utilized in situations where head pull-through capacity or lateral loading is a critical design consideration.



- 1/4 in. [6 mm]
 - 5/16 in. [8 mm]
 - 3/8 in. [10 mm]
 - 1/2 in. [12 mm]
- ℓ • 2 in. to 20-1/2 in. [50 mm to 520 mm]



Engineered Heads

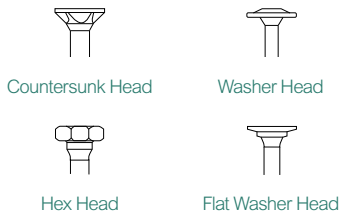

Case-Hardened Steel

A ductile core with a high-density layer on the edge, providing high bending yield strength & ductility



Coated Steel

Fasteners with a zinc and blue passivated coating for use in dry service conditions



Shank Cutter

Taps a larger hole for the unthreaded portion of the shank, reducing the insertion torque



Large Thread

Provides high withdrawal resistance



Reamer Tip

Reduces the need for predrilling and provides the quickest fastener wood bite

CERTIFICATIONS



Product Overview

ASSY Ecofast 4.0

Countersunk-Head Self-Tapping Wood Screw

The ASSY Ecofast is the classic fastener used to achieve a clean and flush architectural finish. Its reamer tip reduces wood splitting while offering quick wood fiber engagement.



Countersunk Head with Milling Pockets



Shank Cutter



Partially Threaded



Reamer Tip

Certifications	ICC-ESR-3179, CCMC 13677-R, ETA-11/0190
Connection Types	Wood to Wood, Steel to Wood
Corrosion Resistance	Regular (refer to page 16)
Core Hardness	≤ 390 HV

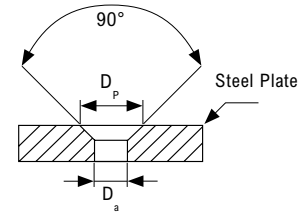
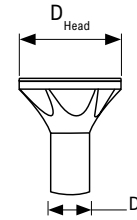
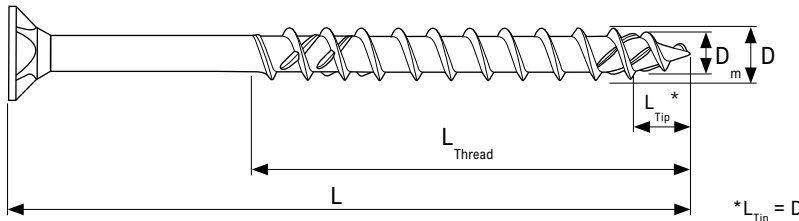

ASSY Ecofast 4.0 - 1/4 in. [6 mm] DIAMETER

Specification Item #	Packaging Qty.	D	L		L _{Thread}	D _{Head}	D _m	D _s	D _p	D _a	Driver Bit	
		in. [mm]	in. [mm]	[mm]	in. [mm]	in. [mm]						
[4] ECO0660	200	1/4 [6]	2-3/8	[60]	1-1/2	[37]	0.472 [12]	0.154 [3.9]	0.173 [4.4]	0.634 [16.1]	0.278 [7]	RW 40
[4] ECO0670	200		2-3/4	[70]	1-5/8	[42]						
[4] ECO0680	100		3-1/8	[80]	2	[50]						
[4] ECO0690	100		3-1/2	[90]	2	[50]						
[4] ECO06100	100		4	[100]	2-3/8	[60]						
[4] ECO06120	100		4-3/4	[120]	2-3/4	[70]						
[4] ECO06140	100		5-1/2	[140]	2-3/4	[70]						
[4] ECO06160	100		6-1/4	[160]	2-3/4	[70]						
[4] ECO06180	100		7-1/8	[180]	2-3/4	[70]						
[4] ECO06200	100		7-7/8	[200]	2-3/4	[70]						
[4] ECO06220	100		8-5/8	[220]	2-3/4	[70]						
[4] ECO06240	100		9-1/2	[240]	2-3/4	[70]						
[4] ECO06260	100		10-1/4	[260]	2-3/4	[70]						
[4] ECO06280	100		11	[280]	2-3/4	[70]						
[4] ECO06300	100		11-3/4	[300]	2-3/4	[70]						

ASSY Ecofast 4.0 - 5/16 in. [8 mm] DIAMETER

Specification	Packaging Qty.	D	L	L _{Thread}	D _{Head}	D _m	D _s	D _p	D _a	Driver Bit
Item #		in. [mm]	in. [mm]	in. [mm]	in. [mm]					
[4] ECO0880	75	5/16 [8]	3-1/8 [80]	2 [50]	0.583 [15]	0.209 [5.3]	0.228 [5.8]	0.736 [18.7]	0.354 [9]	RW 40
[4] ECO0890	150		3-1/2 [90]	2-3/8 [60]						
[4] ECO08100	75		4 [100]	2-3/8 [60]						
[4] ECO08120	75		4-3/4 [120]	3-1/8 [80]						
[4] ECO08140	75		5-1/2 [140]	3-1/8 [80]						
[4] ECO08160	75		6-1/4 [160]	3-1/8 [80]						
[4] ECO08180	75		7-1/8 [180]	3-1/8 [80]						
[4] ECO08200	75		7-7/8 [200]	3-1/8 [80]						
[4] ECO08220	75		8-5/8 [220]	4 [100]						
[4] ECO08240	75		9-1/2 [240]	4 [100]						
[4] ECO08260	75		10-1/4 [260]	4 [100]						
[4] ECO08280	75		11 [280]	4 [100]						
[4] ECO08300	75		11-7/8 [300]	4 [100]						
[4] ECO08320	100		12-5/8 [320]	4 [100]						
[4] ECO08340	100		13-3/8 [340]	4 [100]						
[4] ECO08360	100		14-1/4 [360]	4 [100]						
[4] ECO08380	100		15 [380]	4 [100]						
[4] ECO08400	100		15-3/4 [400]	4 [100]						

ASSY Ecofast 4.0 - 3/8 in. [10 mm] DIAMETER

Specification	Packaging Qty.	D	L	L _{Thread}	D _{Head}	D _m	D _s	D _p	D _a	Driver Bit
Item #		in. [mm]	in. [mm]	in. [mm]	in. [mm]					
[4] ECO1080	50	3/8 [10]	3-1/8 [80]	2 [50]	0.728 [18.5]	0.256 [6.5]	0.283 [7.2]	0.889 [22.6]	0.433 [11]	RW 40
[4] ECO10100	50		4 [100]	2-3/8 [60]						
[4] ECO10120	50		4-3/4 [120]	3-1/8 [80]						
[4] ECO10140	50		5-1/2 [140]	3-1/8 [80]						
[4] ECO10160	50		6-1/4 [160]	4 [100]						
[4] ECO10180	50		7-1/8 [180]	4 [100]						
[4] ECO10200	50		7-7/8 [200]	4 [100]						
[4] ECO10220	50		8-5/8 [220]	4 [100]						
[4] ECO10240	50		9-1/2 [240]	4 [100]						
[4] ECO10260	50		10-1/4 [260]	4 [100]						
[4] ECO10280	50		11 [280]	4 [100]						
[4] ECO10300	50		11-7/8 [300]	4 [100]						
[4] ECO10320	50		12-5/8 [320]	4-3/4 [120]						
[4] ECO10360	50		14-1/4 [360]	4-3/4 [120]						
[4] ECO10400	50		15-3/4 [400]	4-3/4 [120]						



ASSY SK 4.0

Washer-Head Self-Tapping Wood Screw

The ASSY SK is engineered to support a high head pull-through capacity, making it a perfect fit for wood-to-wood applications. Its large head provides a high resistance to head pull-through.



Washer Head



Shank Cutter



Partially Threaded



Reamer Tip

Certifications	ICC-ESR-3179, CCMC 13677-R, ETA-11/0190
Connection Types	Wood to Wood, Steel to Wood
Corrosion Resistance	Regular (refer to page 16)
Core Hardness	≤ 390 HV

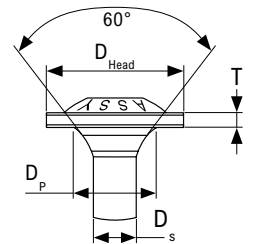
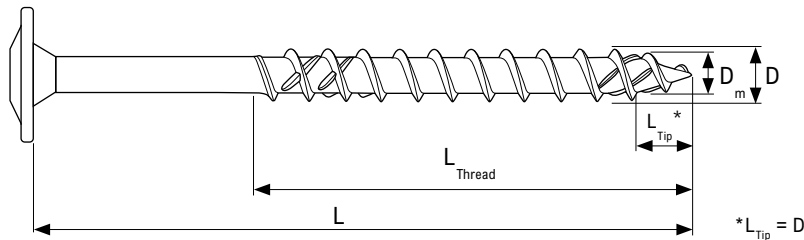

ASSY SK 4.0 - 1/4 in. [6 mm] DIAMETER

Specification	Packaging Qty.	D	L	L _{Thread}	D _{Head}	D _m	D _s	D _p	T	Driver Bit
Item #		in. [mm]	in. [mm]	in. [mm]	in. [mm]					
[4] SK0650	100	1/4 [6]	2 [50]	1-3/4 [45]	0.551 [14]	0.154 [3.9]	0.175 [4.4]	0.315 [8]	0.047 [1.2]	RW 40
[4] SK0660	100		2-3/8 [60]	1-1/2 [37]						
[4] SK0670	100		2-3/4 [70]	1-5/8 [42]						
[4] SK0680	100		3-1/8 [80]	2 [50]						
[4] SK0690	100		3-1/2 [90]	2 [50]						
[4] SK06100	100		4 [100]	2-3/8 [60]						
[4] SK06120	100		4-3/4 [120]	2-3/4 [70]						
[4] SK06140	100		5-1/2 [140]	2-3/4 [70]						
[4] SK06160	100		6-1/4 [160]	2-3/4 [70]						
[4] SK06180	100		7-1/8 [180]	2-3/4 [70]						
[4] SK06200	100		7-7/8 [200]	2-3/4 [70]						
[4] SK06220	100		8-5/8 [220]	2-3/4 [70]						
[4] SK06240	100		9-1/2 [240]	2-3/4 [70]						
[4] SK06260	100		10-1/4 [260]	2-3/4 [70]						
[4] SK06280	100		11 [280]	2-3/4 [70]						
[4] SK06300	100		11-7/8 [300]	2-3/4 [70]						

ASSY SK 4.0 - 5/16 in. [8 mm] DIAMETER

Specification	Packaging	D	L	L _{Thread}	D _{Head}	D _m	D _s	D _p	T	Driver Bit
Item #	Qty.	in. [mm]	in. [mm]	in. [mm]	in. [mm]					Driver Bit
[4] SK0860	50	5/16 [8]	2-3/8 [60]	2 [50]	0.870 [22.1]	0.209 [5.3]	0.228 [5.8]	0.394 [10]	0.071 [1.8]	RW 40
[4] SK0880	50		3-1/8 [80]	2 [50]						
[4] SK08100	50		4 [100]	2-3/8 [60]						
[4] SK08120	50		4-3/4 [120]	3-1/8 [80]						
[4] SK08140	50		5-1/2 [140]	3-1/8 [80]						
[4] SK08160	50		6-1/4 [160]	3-1/8 [80]						
[4] SK08180	50		7-1/8 [180]	3-1/8 [80]						
[4] SK08200	50		7-7/8 [200]	3-1/8 [80]						
[4] SK08220	50		8-5/8 [220]	4 [100]						
[4] SK08240	50		9-1/2 [240]	4 [100]						
[4] SK08260	50		10-1/4 [260]	4 [100]						
[4] SK08280	50		11 [280]	4 [100]						
[4] SK08300	50		11-7/8 [300]	4 [100]						
[4] SK08320	50		12-5/8 [320]	4 [100]						
[4] SK08340	50		13-3/8 [340]	4 [100]						
[4] SK08360	50		14-1/4 [360]	4 [100]						
[4] SK08380	50		15 [380]	4 [100]						
[4] SK08400	50		15-3/4 [400]	4 [100]						
[4] SK08420	50		16-1/2 [420]	4 [100]						
[4] SK08440	50		17-1/4 [440]	4 [100]						
[4] SK08480	25	19 [480]	4 [100]							
[4] SK08500	25	19-5/8 [500]	4 [100]							

ASSY SK 4.0 - 3/8 in. [10 mm] DIAMETER

Specification	Packaging	D	L	L _{Thread}	D _{Head}	D _m	D _s	D _p	T	Driver Bit
Item #	Qty.	in. [mm]	in. [mm]	in. [mm]	in. [mm]					Driver Bit
[4] SK10100	50	3/8 [10]	4 [100]	2-3/8 [60]	0.992 [25.2]	0.256 [6.5]	0.283 [7.2]	0.531 [13.5]	0.087 [2.2]	RW 50
[4] SK10120	50		4-3/4 [120]	3-1/8 [80]						
[4] SK10140	50		5-1/2 [140]	3-1/8 [80]						
[4] SK10160	50		6-1/4 [160]	4 [100]						
[4] SK10180	50		7-1/8 [180]	4 [100]						
[4] SK10200	50		7-7/8 [200]	4 [100]						
[4] SK10220	50		8-5/8 [220]	4 [100]						
[4] SK10240	50		9-1/2 [240]	4 [100]						
[4] SK10260	50		10-1/4 [260]	4 [100]						
[4] SK10280	50		11 [280]	4 [100]						
[4] SK10300	50		11-7/8 [300]	4 [100]						
[4] SK10320	50		12-5/8 [320]	4-3/4 [120]						
[4] SK10340	50		13-3/8 [340]	4-3/4 [120]						
[4] SK10360	50		14-1/4 [360]	4-3/4 [120]						
[4] SK10380	50		15 [380]	4-3/4 [120]						
[4] SK10400	50		15-3/4 [400]	4-3/4 [120]						
[4] SK10460	25		18-1/8 [460]	4-3/4 [120]						

ASSY SK 4.0 - 1/2 in. [12 mm] DIAMETER

Specification	Packaging Qty.	D	L	L _{Thread}	D _{Head}	D _m	D _s	D _p	T	Drive Bit
Item #		in. [mm]	in. [mm]	in. [mm]	in. [mm]					
[4] SK12200	25	1/2 [12]	7-7/8 [200]	4 [100]	1.157 [29.4]	0.283 [7.2]	0.323 [8.2]	0.552 [14]	0.102 [2.6]	RW 50
[4] SK12240	25		9-1/2 [240]	4-3/4 [120]						
[4] SK12260	25		10-1/4 [260]	4-3/4 [120]						
[4] SK12300	25		11-7/8 [300]	4-3/4 [120]						
[4] SK12400	25		15-3/4 [400]	5-3/4 [145]						
[4] SK12480	25		19 [480]	5-3/4 [145]						
[4] SK12520	25		20-1/2 [520]	5-3/4 [145]						

ASSY Kombi 4.0

Hex-Head Self-Tapping Wood Screw

The ASSY Kombi is specifically designed for high-performance steel-to-wood connections. Its reinforced and tapered shoulder has the same diameter as its thread, ensuring a tight fit in predrilled steel plate holes while reducing slip.



Hex Head



Shank Cutter



Partially Threaded



Reamer Tip

Certifications	ICC-ESR-3179, CCMC 13677-R, ETA-11/0190
Connection Types	Steel to Wood
Corrosion Resistance	Regular (refer to page 16)
Core Hardness	≤ 390 HV

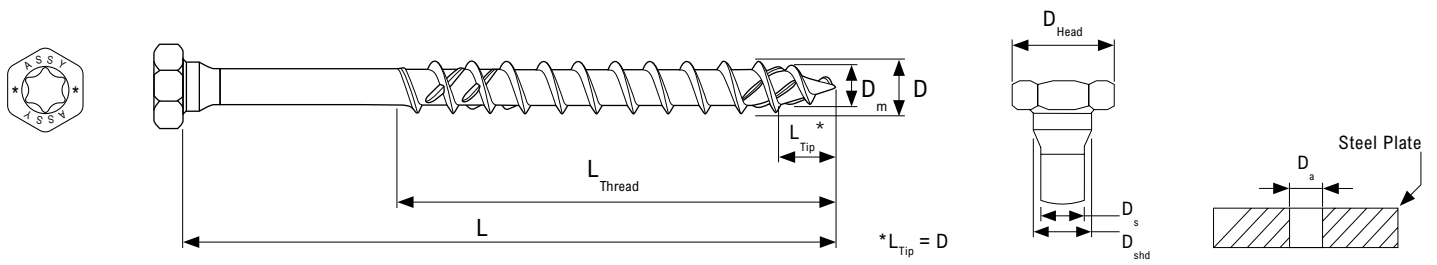

ASSY Kombi 4.0 - 5/16 in. [8 mm] DIAMETER

Specification	Packaging Qty.	D	L	L _{Thread}	D _{Head}	D _m	D _s	D _a	D _{shd}	Driver Bit
Item #		in. [mm]	in. [mm]	in. [mm]	in. [mm]					
[4] KPT0860	75	5/16 [8]	2-3/8 [60]	1-1/2 [40]	0.472 [12]	0.209 [5.3]	0.228 [5.8]	0.354 [9]	0.315 [8]	RW 40 or 1/2 Hex Socket
[4] KPT0880	75		3-1/8 [80]	2 [50]						
[4] KPT08100	75		4 [100]	2-3/8 [60]						
[4] KPT08120	75		4-3/4 [120]	3-1/8 [80]						
[4] KPT08140	75		5-1/2 [140]	3-1/8 [80]						
[4] KPT08160	75		6-1/4 [160]	3-1/8 [80]						
[4] KPT08180	75		7-1/8 [180]	3-1/8 [80]						
[4] KPT08200	75		7-7/8 [200]	3-1/8 [80]						
[4] KPT08240	75		9-1/2 [240]	4 [100]						
[4] KPT08300	75		11-7/8 [300]	4 [100]						

ASSY Kombi 4.0 - 3/8 in. [10 mm] DIAMETER

Specification	Packaging Qty.	D	L	L _{Thread}	D _{Head}	D _m	D _s	D _a	D _{shd}	Driver Bit
Item #		in. [mm]	in. [mm]	in. [mm]	in. [mm]					
[4] KPT1080	50	3/8 [10]	3-1/8 [80]	2 [50]	0.591 [15]	0.256 [6.5]	0.283 [7.2]	0.433 [11]	0.394 [10]	RW 40 or 19/32 Hex Socket
[4] KPT10100	50		4 [100]	2-3/8 [60]						
[4] KPT10120	50		4-3/4 [120]	3-1/8 [80]						
[4] KPT10140	50		5-1/2 [140]	3-1/8 [80]						
[4] KPT10160	50		6-1/4 [160]	4 [100]						
[4] KPT10180	50		7-1/8 [180]	4 [100]						
[4] KPT10200	50		7-7/8 [200]	4 [100]						
[4] KPT10300	50		11-7/8 [300]	4 [100]						

ASSY Kombi 4.0 - 1/2 in. [12 mm] DIAMETER

Specification	Packaging Qty.	D	L	L _{Thread}	D _{Head}	D _m	D _s	D _a	D _{shd}	Driver Bit
Item #		in. [mm]	in. [mm]	in. [mm]	in. [mm]					
[4] KPT12100	50	1/2 [12]	4 [100]	2-3/8 [60]	0.669 [17]	0.283 [7.2]	0.323 [8.2]	0.511 [13]	0.472 [12]	RW 40 or 11/16 Socket
[4] KPT12140	50		5-1/2 [140]	3-1/8 [80]						
[4] KPT12180	50		7-1/8 [180]	4 [100]						
[4] KPT12200	50		7-7/8 [200]	4 [100]						
[4] KPT12220	50		8-5/8 [220]	4-3/4 [120]						
[4] KPT12300	50		11-7/8 [300]	4-3/4 [120]						

ASSY Kombi LT 4.0

Hex-Head Self-Tapping Wood Screw

The ASSY Kombi LT is a long-threaded version of the ASSY Kombi, specifically designed for high-performance steel-to-wood connections. Its reinforced and tapered shoulder has the same diameter as its thread, ensuring a tight fit in predrilled steel plate holes while reducing slip.



Hex Head



Fully Threaded



Counter Thread Tip

Certifications	ICC-ESR-3179, CCMC 13677-R, ETA-11/0190
Connection Types	Steel to Wood
Corrosion Resistance	Regular (refer to page 16)
Core Hardness	≤ 390 HV

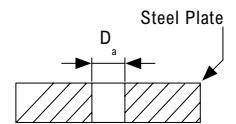
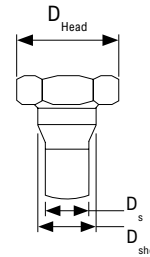
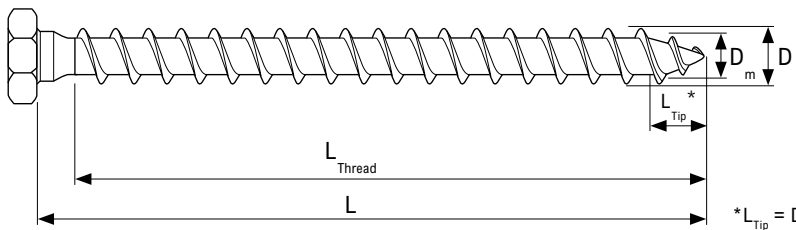

ASSY Kombi LT 4.0 - 1/2 in. [12 mm] DIAMETER

Specification	Packaging Qty.	D	L	L _{Thread}	D _{Head}	D _m	D _s	D _a	D _{shd}	Drive Bit
Item #		in. [mm]	in. [mm]	in. [mm]	in. [mm]					
[4] KLT1280	50	1/2 [12]	3-1/8 [80]	2-3/4 [70]	0.669 [17]	0.283 [7.2]	0.322 [8.2]	0.511 [13]	0.472 [12]	RW 40 or 11/16 Socket
[4] KLT12120	50		4-3/4 [120]	4 [100]						
[4] KLT12160	50		6-1/4 [160]	5-3/4 [145]						

ASSY FWH 4.0

Flat Washer-Head Self-Tapping Wood Screw

The ASSY FWH is a multi-purpose fastener that combines the pulling power of the washer-head screw with the clean flush finish of the countersunk-head screw. It is engineered to accommodate multilayer connections and roof membrane applications.

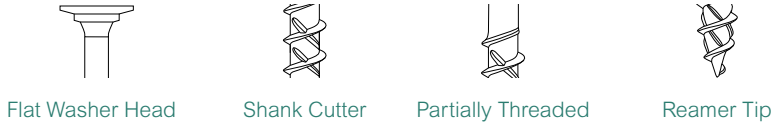

Certifications	ICC-ESR-3179, ETA-11/0190
Connection Types	Wood to Wood
Corrosion Resistance	Regular (refer to page 16)
Core Hardness	≤ 390 HV

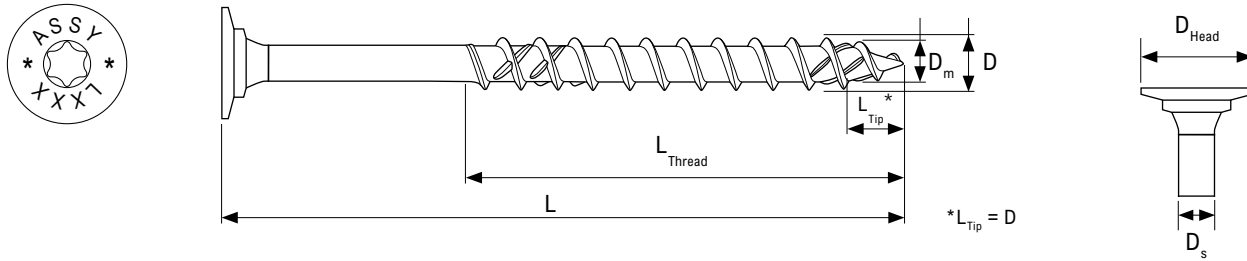

ASSY FWH 4.0 - 5/16 in. [8 mm] DIAMETER

Specification	Packaging	D	L	L _{Thread}	D _{Head}	D _m	D _s	Drive Bit
Item #	Qty.	in. [mm]	in. [mm]	in. [mm]	in. [mm]			
[4] FWH08080	50	5/16 [8]	3-1/8 [80]	2 [50]	0.724 [18.4]	0.209 [5.3]	0.228 [5.8]	RW 40
[4] FWH08100	50		4 [100]	2-3/8 [60]				
[4] FWH08160	50		6-1/4 [160]	3-1/8 [80]				
[4] FWH08200	50		7-7/8 [200]	3-1/8 [80]				
[4] FWH08240	50		9-1/2 [240]	4 [100]				
[4] FWH08300	50		11-7/8 [300]	4 [100]				
[4] FWH08360	50		14-1/4 [360]	4 [100]				
[4] FWH08400	50		15-3/4 [400]	4 [100]				

Reference Design Values

2.1 - Reference Withdrawal Design Values, W_{90} , for Partially Threaded Fastener 4.0 Series

Diameter [in.]	W_{90} [lb./in.]				
	Specific Gravity [G]				
	Lumber & Glulam				PSL
	G = 0.35	G = 0.42	G = 0.49	G = 0.55	ESG ≥ 0.50
1/4	137	169	202	230	156
5/16	176	212	248	279	179
3/8	190	237	280	317	211
1/2	211	254	297	334	223

Notes:

- Reference design values for 1/2 in. screws presented in this table are based on testing performed in accordance with AC 233. Remaining reference design values are based on ICC-ESR-3179 (2024).
- Tabulated reference withdrawal design values, W_{90} , apply to screws installed perpendicular to the grain of the wood member. For screws installed at an angle to the wood grain, W_{90} shall be reduced by the appropriate angle-to-grain reduction factor, R_a , to obtain the applicable angle-to-grain withdrawal design value [see eq. 1].
- G refers to the specific gravity assigned to the wood species. ESG must be the equivalent specific gravity given in the ICC-ESR evaluation report of PSL.
- Connection design must meet all relevant requirements of the General Notes to the Designer section.

2.2 - Reference Head Pull-Through Design Values, W_H , for Partially Threaded Fastener 4.0 Series

Diameter [in.]	Fastener Type	W_H [lb.]				
		Specific Gravity [G]				
		Lumber & Glulam				PSL
		G = 0.35	G = 0.42	G = 0.49	G = 0.55	ESG ≥ 0.50
1/4	Ecofast 4.0	133	163	194	221	262
	SK 4.0	244	299	356	407	440
5/16	Ecofast 4.0	187	232	277	318	327
	SK 4.0	410	510	604	685	732
	Kombi 4.0	146	188	233	275	326
	FWH 4.0	—	406	480	—	—
3/8	Ecofast 4.0	246	319	385	445	509
	SK 4.0	513	593	660	710	797
	Kombi 4.0	225	278	327	369	420
1/2	SK 3.0	517	627	738	834	939
	Kombi 3.0	257	305	351	390	474

Notes:

- Reference design values for 1/2 in. screws presented in this table are based on testing performed in accordance with AC 233. Remaining reference design values are based on ICC-ESR-3179 (2024).
- Design values are applicable to connections with a wood side member thickness of at least 1-3/8 in.
- Connection design must meet all relevant requirements of the Notes to the Designer section.
- G refers to the specific gravity assigned to the wood species. ESG must be the equivalent specific gravity given in the ICC-ESR evaluation report of PSL.
- Tabulated head pull-through design values, W_H , are applicable to screws installed perpendicular to the faces of the wood members and must be multiplied by all adjustment factors included in NDS 2024 for dowel-type fasteners to determine allowable loads for use with ASD and/or design loads for use with LRFD [see eq. 2].

2.3 - Fastener Strength Values for Partially Threaded Fastener 4.0 Series

Diameter [in.]	Bending Yield Strength, F_{yb} [psi]	Tensile Strength, T_s [lb.]		Shear Strength, V [lb.]		Allowable Insertion Torque [lb.-ft]
		ASD	LRFD	ASD	LRFD	
1/4	181,200	1,075	1,610	700	1,050	4.9
5/16	164,600	1,790	2,685	1,220	1,830	11.3
3/8	170,200	2,690	4,040	1,930	2,890	22.1
1/2	166,300	3,887	5,831	2,529	3,794	32.0

Notes:

1. Connection design must meet all relevant requirements of the General Notes to the Designer section.
2. Bending yield strength is determined in accordance with ASTM F1575 using the minor diameter of the fastener.
3. The allowable insertion torque is determined in accordance with EAD 130118-01-0603, where the ratio of torsional strength to insertion torque should be at least 1.5.
4. Specified bending yield strength, tensile strength, and shear strength values presented in this table are based on ICC-ESR-3179 (2024).

Geometry Requirements

Glulam & Timber

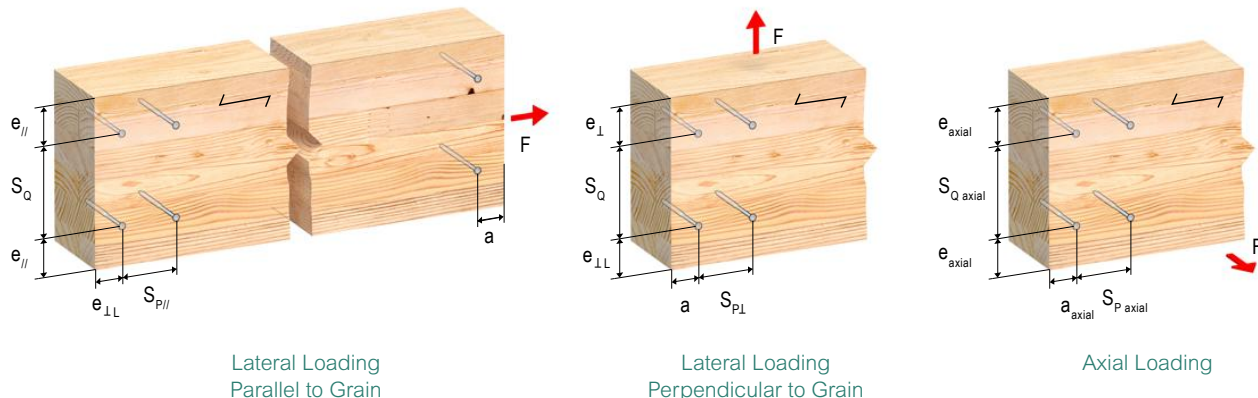

2.4 - Geometry Requirements for Partially Threaded Self-Tapping Screw 4.0 Series for Glulam and Timber

Loading Configuration			Installation Configuration Glulam & Timber		
			Self-Tapping Screws		Predrilling
			$G < 0.5$	$G \geq 0.5$	Any G
End Distance	Lateral loading parallel to grain in tension	a_L	15D*	20D	7D
	Lateral loading parallel to grain in compression	a	10D*	15D	4D
	Lateral loading perpendicular to grain	a	10D*	15D	4D
	Axial loading	a_{axial}	10D*	10D	4D
Edge Distance	Lateral loading parallel to grain	e_{\parallel}	5D	7D	3D
	Lateral loading perpendicular to grain, toward edge	$e_{\perp L}$	10D	12D	4D
	Lateral loading perpendicular to grain, away from edge	e_{\perp}	5D	7D	4D
	Axial loading	e_{axial}	4D	4D	3D
Spacing between Fasteners in a Row [parallel to grain]	Lateral loading parallel to grain	S_{\parallel}	15D*	15D	4D
	Lateral loading perpendicular to grain	S_{\perp}	10D*	10D	4D
	Axial loading	$S_{P\ axial}$	7D*	7D	4D
Spacing between Rows [perpendicular to grain]	Lateral loading parallel to grain	S_Q	5D	7D	5D
	Lateral loading; staggered rows	$S_{Q\ S}$	2.5D	3D	—
	Axial loading ($D \leq 5/16"$)	$S_{Q\ axial}$	4D	4D	4D
	Axial loading ($D > 5/16"$)	$S_{Q\ axial}$	5D	5D	4D

* For species prone to splitting, including Douglas Fir-Larch, minimum geometry requirements may need to be increased.

Notes:

- All connection design must meet all the relevant requirements outlined in the General Notes to the Designer section.
- Values for spacing between staggered rows apply where fasteners in adjacent rows are offset by half of the spacing between fasteners in a row.
- Within a row, fasteners may be staggered up to 2D to further reduce the potential for splitting.
- The geometry requirements for staggered rows are per ICC-ESR-3179 (2024). All remaining geometry requirements are per NDS 2024 Section 12.5.1.
- The minimum geometry requirements outlined in this section are meant to provide sufficient end and edge distances, as well as spacings between rows and between fasteners in a row, to reduce the potential for splitting.
- Applying the minimum requirements does not prevent wood failure, such as row tear-out, group tear-out, block tear-out, net tension failure, or splitting perpendicular to grain.

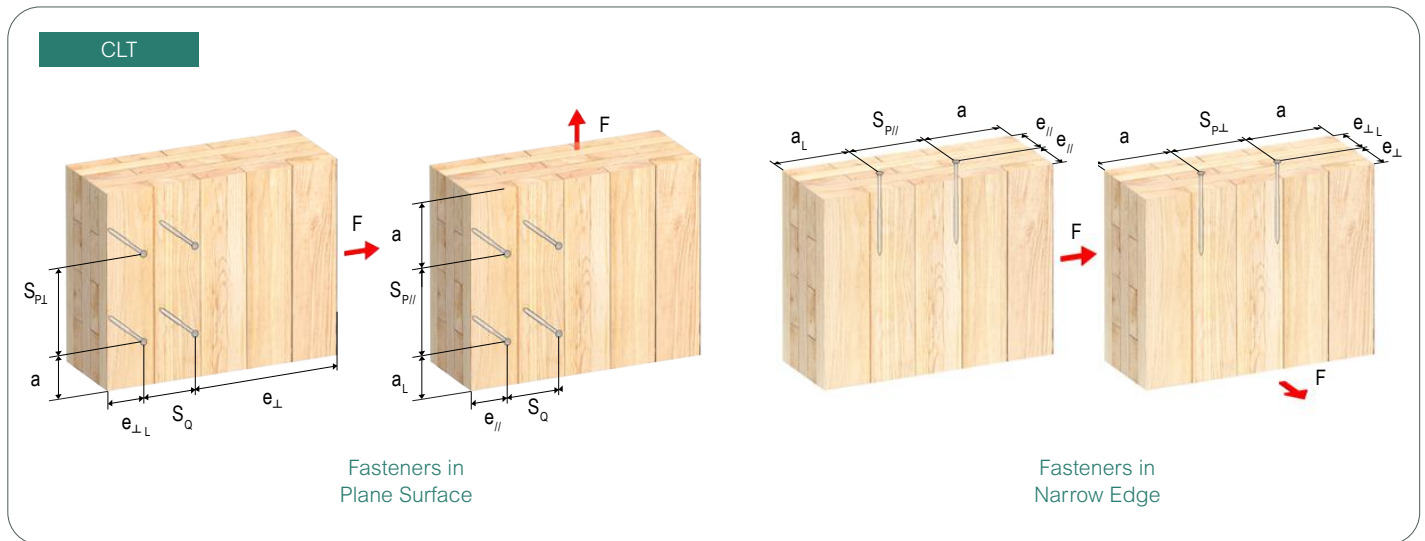

2.5 - Geometry Requirements for Partially Threaded Self-Tapping Screw 4.0 Series for CLT

Loading Configuration		Installation Configuration CLT [$G = 0.42$]	
		Self-Tapping Screws	
		Surface	Edge
End Distance	Lateral loading parallel to grain in tension	a_L	6D
	Lateral loading parallel to grain in compression	a	7D
	Lateral loading perpendicular to grain	a	6D
	Axial loading	a_{axial}	7D
Edge Distance	Lateral loading parallel to grain	e_{\parallel}	2.5D
	Lateral loading perpendicular to grain, toward edge	$e_{\perp L}$	6D
	Lateral loading perpendicular to grain, away from edge	e_{\perp}	2.5D
	Axial loading	e_{axial}	3D
Spacing Between Fasteners in a Row [parallel to grain]	Lateral loading parallel to grain	$S_{P\parallel}$	4D
	Lateral loading perpendicular to grain	$S_{P\perp}$	10D
	Axial loading	S_{Paxial}	4D
Spacing Between Rows [perpendicular to grain]	Lateral loading parallel to grain	S_Q	2.5D
	Axial loading	S_{Qaxial}	4D

Notes:

- All connection design must meet all the relevant requirements outlined in the Notes to the Designer section.
- For species prone to splitting (e.g., Douglas Fir and Hem-Fir), it is recommended that the parallel-to-grain spacing requirements be increased by 50%.
- Within a row, fasteners may be staggered up to 2D to further reduce the potential for splitting.
- The listed values are applicable when the CLT panel thickness is at least 10D.
- The minimum penetration length of the screw into the narrow face of the panel shall be 10D.
- The values provided are in accordance with ETA-11/0190.
- The minimum geometry requirements outlined in this table are meant to provide sufficient end and edge distances, as well as spacings between fasteners, to reduce the potential for splitting.
- Applying the minimum requirements does not prevent wood failure, such as row tear-out, group tear-out, block tear-out, net tension failure, or splitting perpendicular to grain.



Clayton Community Center

Surrey, British Columbia



First Tech Federal Credit Union

Hillsboro, Oregon

Fully Threaded Fastener Series

MTC Solutions self-tapping Fully Threaded fasteners are designed to hold wood members firmly in place, often utilized to take advantage of their high withdrawal capacity during axial loading.



- 1/4 in. [6 mm]
 - 5/16 in. [8 mm]
 - 3/8 in. [10 mm]
 - 1/2 in. [12 mm]
 - 9/16 in. [14 mm]
- ℓ • 3-1/8 in. to 59 in. [80 mm to 1500 mm]



Engineered Heads



Countersunk Head



Cylinder Head



Reverse Head



Case-Hardened Steel

A ductile core with a high density layer on the edge, providing high bending yield strength & ductility



Coated Steel

Fasteners with a zinc and blue passivated coating for use in dry service conditions



Large Thread

Provides high withdrawal resistance



Drilling Tip

Reduces both the need for predrilling and the typical geometry requirements

CERTIFICATIONS



ICC-ESR-3178



13677-R

ISO 50001

Energy Management System



ETA-11/0190

Product Overview

ASSY VG CSK

Countersunk-Head Self-Tapping Wood Screw

The ASSY VG CSK is a multi-purpose fastener, suitable for wood reinforcement as well as wood-to-wood and steel-to-wood connections.



Countersunk Head with Milling Pockets



Fully Threaded



Drilling Tip

Certifications	ICC-ESR-3178, CCMC 13677-R, ETA-11/0190
Connection Types	Wood to Wood, Steel to Wood, Concrete to Wood
Corrosion Resistance	Regular (refer to page 16)
Core Hardness	≤ 390 HV

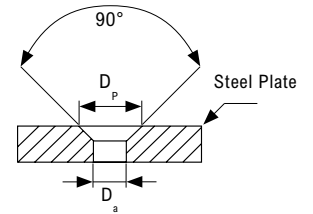
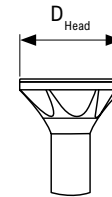
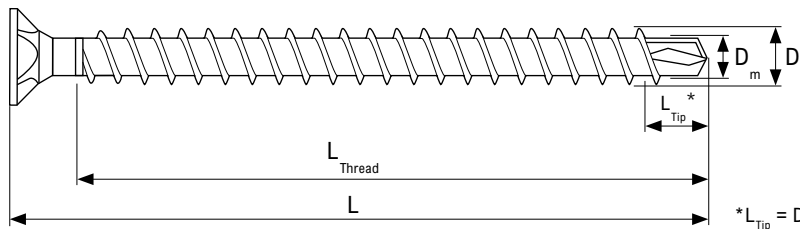
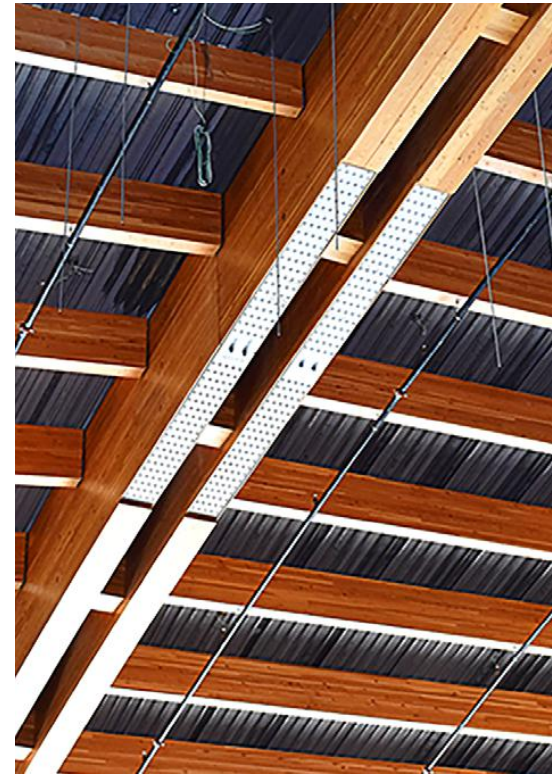

ASSY VG CSK - 5/16 in. [8 mm] DIAMETER

Specification	Packaging Qty.	D	L	L _{Threading}	D _{Head}	D _m	D _a	D _p	Driver Bit
Item #		in. [mm]	in. [mm]	in. [mm]	in. [mm]				
CSK0880	75	5/16 [8]	3-1/8 [80]	2-1/2 [61]	0.583 [15]	0.197 [5]	0.354 [9]	0.736 [18.7]	RW 40
CSK08120	75		4-3/4 [120]	4 [103]					
CSK08140	75		5-1/2 [140]	4-7/8 [123]					
CSK08160	75		6-1/4 [160]	5-5/8 [143]					
CSK08180	75		7-1/8 [180]	6-3/8 [163]					
CSK08200	75		7-7/8 [200]	7-1/4 [183]					
CSK08220	75		8-5/8 [220]	8 [203]					
CSK08240	75		9-1/2 [240]	8-3/4 [223]					
CSK08260	75		10-1/4 [260]	9-5/8 [243]					
CSK08280	75		11 [280]	10-3/8 [263]					
CSK08300	75		11-7/8 [300]	11-1/8 [283]					

ASSY VG CSK - 3/8 in. [10 mm] DIAMETER

Specification	Packaging Qty.	D	L	L _{Thread}	D _{Head}	D _m	D _a	D _p	Driver Bit
Item #		in. [mm]	in. [mm]	in. [mm]	in. [mm]				
CSK10100	50	3/8 [10]	4 [100]	3 [77]	0.774 [20]	0.244 [6.2]	0.433 [11]	0.984 [25]	RW 50
CSK10120	50		4-3/4 [120]	4-1/8 [102]					
CSK10140	50		5-1/2 [140]	4-7/8 [125]					
CSK10160	50		6-1/4 [160]	5-3/4 [145]					
CSK10180	50		7-1/8 [180]	6-1/2 [165]					
CSK10200	50		7-7/8 [200]	7-1/4 [185]					
CSK10220	50		8-5/8 [220]	8-1/8 [205]					
CSK10240	50		9-1/2 [240]	8-7/8 [225]					
CSK10260	50		10-1/4 [260]	9-5/8 [245]					
CSK10280	50		11 [280]	10-3/8 [265]					
CSK10300	50		11-7/8 [300]	11-1/4 [285]					
CSK10320	50		12-5/8 [320]	12 [305]					
CSK10340	50		13-3/8 [340]	12-3/4 [325]					
CSK10360	50		14-1/4 [360]	13-5/8 [345]					
CSK10380	50		15 [380]	14-3/8 [365]					
CSK10400	50		15-3/4 [400]	15-1/8 [385]					
CSK10430	25		16-7/8 [430]	16-3/8 [415]					
CSK10480	25		19 [480]	18-1/4 [465]					
CSK10530	25		20-7/8 [530]	20-1/8 [512]					
CSK10580	25		22-7/8 [580]	22-1/8 [562]					
CSK10650	25	25-5/8 [650]	24-7/8 [632]						
CSK10700	25	27-5/8 [700]	26-7/8 [682]						
CSK10750	25	29-1/2 [750]	28-7/8 [732]						
CSK10800	25	31-1/2 [800]	30-3/4 [782]						

ASSY VG CSK - 1/2 in. [12 mm] DIAMETER

Specification	Packaging Qty.	D	L	L _{Thread}	D _{Head}	D _m	D _a	D _p	Driver Bit
Item #		in. [mm]	in. [mm]	in. [mm]	in. [mm]				
CSK12120	50	1/2 [12]	4-3/4 [120]	4-1/8 [105]	0.868 [22]	0.280 [7.1]	0.512 [13]	1.063 [27]	RW 50
CSK12140	50		5-1/2 [140]	4-7/8 [125]					
CSK12160	50		6-1/4 [160]	5-3/4 [145]					
CSK12180	50		7-1/8 [180]	6-1/2 [165]					
CSK12200	50		7-7/8 [200]	7-1/4 [185]					
CSK12220	50		8-5/8 [220]	8-1/8 [205]					
CSK12240	50		9-1/2 [240]	8-7/8 [225]					
CSK12260	50		10-1/4 [260]	9-5/8 [245]					
CSK12280	50		11 [280]	10-3/8 [265]					
CSK12300	50		11-7/8 [300]	11-1/4 [285]					
CSK12380	50		15 [380]	14-3/8 [365]					
CSK12480	25		19 [480]	18-1/4 [465]					
CSK12600	25		23-5/8 [600]	23 [585]					



ASSY VG CYL

Cylinder-Head Self-Tapping Wood Screw

The ASSY VG CYL, with its small and easily concealed head, is ideal for wood reinforcement and concealed connections.



Cylinder Head



Fully Threaded



Drilling Tip



Certifications	ICC-ESR-3178, CCMC 13677-R, ETA-11/0190
Connection Types	Wood to Wood, Concrete to Wood
Corrosion Resistance	Regular (refer to page 16)
Core Hardness	≤ 390 HV

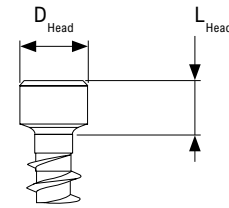
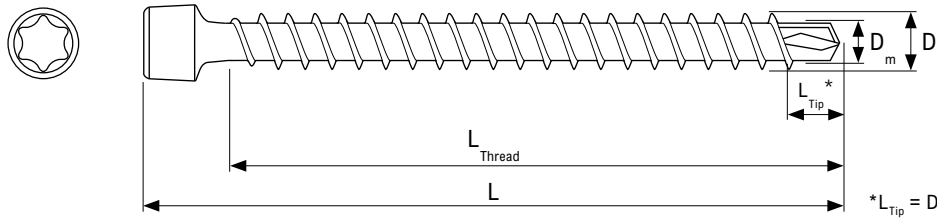

ASSY VG CYL - 5/16 in. [8 mm] DIAMETER

Specification Item #	Packaging Qty.	D	L		L _{Thread}	D _{Head}	D _m	L _{Head}	Driver Bit	
		in. [mm]	in. [mm]	[mm]	in. [mm]	in. [mm]				
CYL08120	50	5/16 [8]	4-3/4	[120]	4	0.390 [10]	0.197 [5]	0.295 [7.5]	RW 40	
CYL08140	50		5-1/2	[140]	4-7/8					[124]
CYL08160	50		6-1/4	[160]	5-5/8					[144]
CYL08180	50		7-1/8	[180]	6-1/2					[164]
CYL08200	75		7-7/8	[200]	7-1/4					[184]
CYL08220	75		8-5/8	[220]	8					[204]
CYL08240	75		9-1/2	[240]	8-7/8					[224]
CYL08260	75		10-1/4	[260]	9-5/8					[244]
CYL08280	75		11	[280]	10-3/8					[264]
CYL08300	75		11-7/8	[300]	11-1/8					[284]
CYL08330	50		13	[330]	12-3/8					[314]
CYL08360	50		14-1/4	[360]	13-1/2					[344]
CYL08380	50		15	[380]	14-3/8					[364]
CYL08430	25		17	[430]	16-1/4					[414]
CYL08480	25		19	[480]	18-1/4					[464]
CYL08530	25		20-7/8	[530]	20-1/4					[514]
CYL08580	25	22-7/8	[580]	22-1/4	[564]					

ASSY VG CYL - 3/8 in. [10 mm] DIAMETER

Specification	Packaging Qty.	D	L	L _{Thread}	D _{Head}	D _m	L _{Head}	Driver Bit
Item #		in. [mm]	in. [mm]	in. [mm]	in. [mm]			
CYL10180	50	3/8 [10]	7-1/8 [180]	6-1/2 [165]	0.528 [13.4]	0.244 [6.2]	0.315 [8]	RW 50
CYL10200	50		7-7/8 [200]	7-1/4 [185]				
CYL10220	50		8-5/8 [220]	8-1/8 [205]				
CYL10240	50		9-1/2 [240]	8-7/8 [225]				
CYL10260	50		10-1/4 [260]	9-5/8 [245]				
CYL10280	50		11 [280]	10-3/8 [265]				
CYL10300	50		11-7/8 [300]	11-1/4 [285]				
CYL10320	50		12-5/8 [320]	12 [305]				
CYL10340	50		13-3/8 [340]	12-3/4 [325]				
CYL10360	50		14-1/4 [360]	13-5/8 [345]				
CYL10380	50		15 [380]	14-3/8 [365]				
CYL10400	50		15-3/4 [400]	15-1/8 [385]				
CYL10430	25		17 [430]	16-3/8 [415]				
CYL10480	25		19 [480]	18 [456]				
CYL10530	25		20-7/8 [530]	19-7/8 [506]				
CYL10580	25		22-7/8 [580]	21-7/8 [556]				
CYL10650	25		25-5/8 [650]	24-5/8 [626]				
CYL10700	25		27-5/8 [700]	26-5/8 [676]				
CYL10750	25		29-1/2 [750]	28-5/8 [726]				
CYL10800	25		31-1/2 [800]	30-1/2 [776]				

ASSY VG RH

Reverse-Head Self-Tapping Wood Screw

The ASSY VG RH is currently the longest fully threaded fastener of its kind in the world. Performing a function similar to that of rebar in concrete, it provides a strong and reliable reinforcing solution for large mass timber projects.



Reverse Head



Fully Threaded



Drilling Tip



Certifications	ETA -11/0190
Connection Types	Large-Scale Wood Reinforcement
Corrosion Resistance	Regular (refer to page 16)
Core Hardness	≤ 390 HV

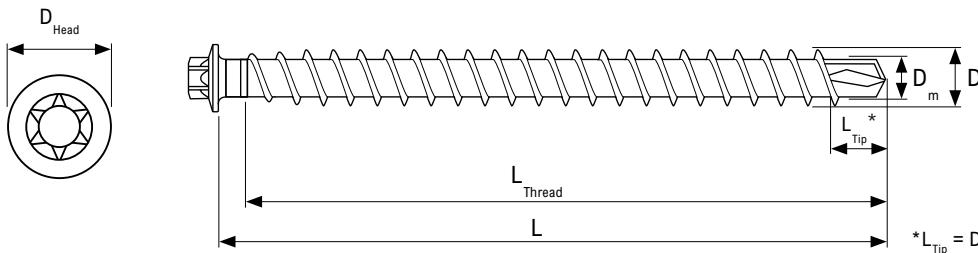

ASSY VG RH - 9/16 in. [14 mm] DIAMETER

Specification Item #	Packaging Qty.	D		L		L _{Thread}		D _{Head} / D _m		Drive Bit
		in. [mm]	in. [mm]	in. [mm]	in. [mm]	in. [mm]	in. [mm]			
RH14800	15	9/16 [14]	31-1/2	[800]	30-3/4	[780]	0.709 [18]	0.335 [8.5]	Reverse Head Socket	
RH14850	15		33-1/2	[850]	32-5/8	[830]				
RH14900	15		35-3/8	[900]	34-5/8	[880]				
RH14950	15		37-3/8	[950]	36-5/8	[930]				
RH141000	15		39-3/8	[1000]	38-5/8	[980]				
RH141050	15		41-3/8	[1050]	40-1/2	[1030]				
RH141100	15		43-1/4	[1100]	42-1/2	[1080]				
RH141200	15		47-1/4	[1200]	46-1/2	[1180]				
RH141300	15		51-1/8	[1300]	50-3/8	[1280]				
RH141400	15		55-1/8	[1400]	54-3/8	[1380]				
RH141500	15		59	[1500]	58-1/4	[1480]				

Note:

- The ASSY VG RH is installed using a reverse-head socket. Details about this socket are provided in the Accessories section.



Ritchie Market

Edmonton, Alberta

Reference Design Values

3.1 - Reference Withdrawal Design Values, W_{90} , for Fully Threaded Fastener Series

Diameter [in.]	W_{90} [lb./in.]				
	Specific Gravity [G]				
	Lumber & Glulam				PSL
	G = 0.35	G = 0.42	G = 0.49	G = 0.55	ESG ≥ 0.50
1/4	137	169	202	230	156
5/16	176	212	248	279	179
3/8	188	237	280	317	211
1/2	209	251	297	331	223
9/16	—	300	347	430	—

- Notes:
- Reference design values are based on ICC-ESR-3179 (2024).
 - Tabulated reference withdrawal design values, W_{90} , apply to screws installed perpendicular to the grain of the wood member. For screws installed at an angle to the wood grain, W_{90} shall be reduced by the appropriate angle-to-grain reduction factor, R_a , to obtain the applicable angle-to-grain withdrawal design value [see eq. 1].
 - G refers to the specific gravity assigned to the wood species. ESG must be the equivalent specific gravity given in the ICC-ESR evaluation report of PSL.
 - Connection design must meet all relevant requirements of the General Notes to the Designer section.

3.2 - Reference Head Pull-Through Design Values, W_H , for Fully Threaded Fastener Series

Diameter [in.]	Fastener Type	W_H [lb.]				
		Specific Gravity [G]				
		Lumber & Glulam				PSL
		G = 0.35	G = 0.42	G = 0.49	G = 0.55	ESG ≥ 0.50
5/16	VG CSK	216	281	350	414	398
3/8		266	334	408	474	491
1/2		266	334	408	474	491

- Notes:
- Reference design values are based on ICC-ESR-3179 (2024).
 - Design values are applicable to connections with a wood side member thickness of at least 1-3/8 in.
 - Connection design must meet all relevant requirements of the Notes to the Designer section.
 - G refers to the specific gravity assigned to the wood species. ESG must be the equivalent specific gravity given in the ICC-ESR evaluation report of PSL.
 - Tabulated head pull-through design values, W_H , are applicable to screws installed perpendicular to the faces of the wood members and must be multiplied by all adjustment factors included in NDS 2024 for dowel-type fasteners to determine allowable loads for use with ASD and/or design loads for use with LRFD [see eq. 2].

3.3 - Reference Buckling Resistance Values, W_c , for Fully Threaded Fastener Series

Diameter [in.]	W_c [lb.]	
	ASD	LRFD
5/16	1,430	4,080
3/8	2,220	6,430

- Notes:
- ASD design values were derived with a factor of safety of 5 applied to the average ultimate capacity of the screws tested for buckling in accordance with AC 233 Section 3.3.1.
 - LRFD values were derived using the 5th percentile Weibull 2-parameter analysis as per ASTM D5457, which includes a ϕ of 0.65 for screws embedded in wood.
 - Testing was conducted in glulam specimens of Douglas Fir (D. Fir), Black Spruce and Southern Yellow Pine (SYP).
 - The values in the table above are applicable for fully threaded ASSY VG screws in diameters of 5/16 in. [8 mm] and 3/8 in. [10 mm].

3.4 - Fastener Strength Values for Fully Threaded Fastener Series

Diameter [in.]	Bending Yield Strength, F_{yb} [psi]	Tensile Strength, T_s [lb.]		Shear Strength, V [lb.]		Allowable Insertion Torque [lb.-ft]
		ASD	LRFD	ASD	LRFD	
1/4	129,200	1,165	1,750	590	885	5.7
5/16	150,000	1,775	2,665	1,105	1,660	12.3
3/8	160,000	2,550	3,825	1,835	2,755	22.1
1/2	166,300	3,470	5,205	2,095	3,145	36.9
9/16	181,300	5,135	7,700	3,200	4,800	56.5

Notes:

1. Connection design must meet all relevant requirements of the General Notes to the Designer section.
2. Bending yield strength is determined in accordance with ASTM F1575 using the minor thread diameter of the fastener.
3. The allowable insertion torque is determined in accordance with EAD 130118-01-0603, where the ratio of torsional strength to insertion torque should be at least 1.5.
4. Bending yield strength, tensile strength, and shear strength values are based on ICC-ESR-3179 (2024).

Geometry Requirements

Glulam & Timber

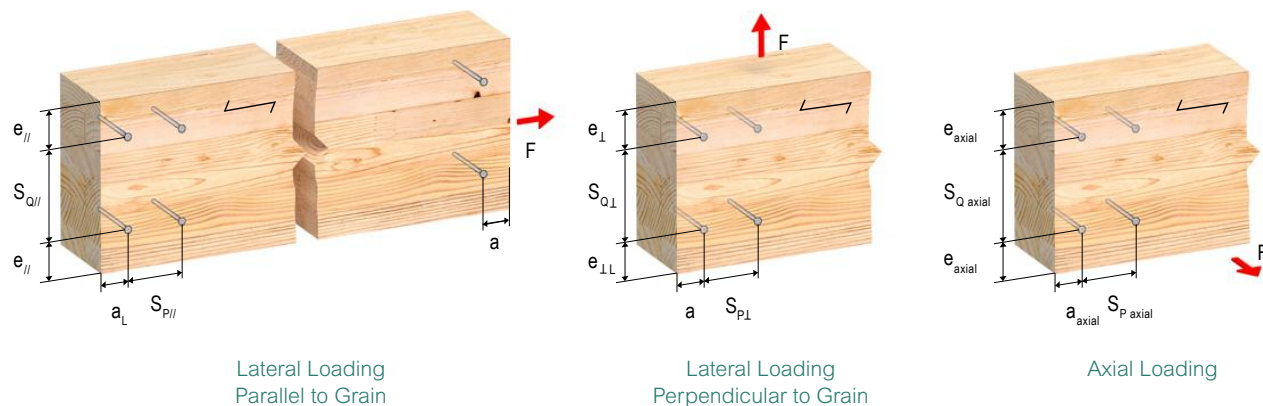

3.5 - Geometry Requirements for Fully Threaded Self-Tapping Screws for Glulam and Timber

Loading Configuration		Installation Configuration Glulam & Timber		
		Self-Tapping Screws		
		D ≤ 3/8"	D > 3/8"	
End Distance	Lateral loading parallel to grain in tension	a_L	12D	7D
	Lateral loading parallel to grain in compression	a	7D	4D
	Lateral loading perpendicular to grain	a	7D	4D
	Axial loading	a_{axial}	7D	4D
Edge Distance	Lateral loading parallel to grain	$e_{ }$	3D	3D
	Lateral loading perpendicular to grain, toward edge	$e_{\perp L}$	7D	4D
	Lateral loading perpendicular to grain, away from edge	e_{\perp}	3D	3D
	Axial loading	e_{axial}	3D	3D
Spacing Between Fasteners in a Row [parallel to grain]	Lateral loading parallel to grain	$S_{P }$	10D	5D
	Lateral loading perpendicular to grain	$S_{P\perp}$	5D	4D
	Axial loading	$S_{P axial}$	7D	5D
Spacing Between Rows [perpendicular to grain]	Lateral loading parallel to grain	$S_{Q }$	4D	5D
	Lateral loading perpendicular to grain	$S_{Q\perp}$	4D	5D
	Axial loading	$S_{Q axial}$	2.5D	5D

Notes:

- All connection design must meet all the relevant requirements outlined in the General Notes to the Designer section.
- For species prone to splitting (e.g., Douglas Fir, Hem-Fir, and Western Red Cedar), it is recommended that the parallel-to-grain spacing requirements be increased by 50%.
- Within a row, fasteners may be staggered up to 2D to further reduce the potential for splitting.
- The geometry requirements are in accordance with ICC-ESR-3178 (2023).
- The minimum geometry requirements outlined in this table are meant to provide sufficient end and edge distances, as well as spacings between rows and between fasteners in a row, to reduce the potential for splitting.
- Applying the minimum requirements does not prevent wood failure such as row tear-out, group tear-out, block tear-out, net tension failure, or splitting perpendicular to grain.

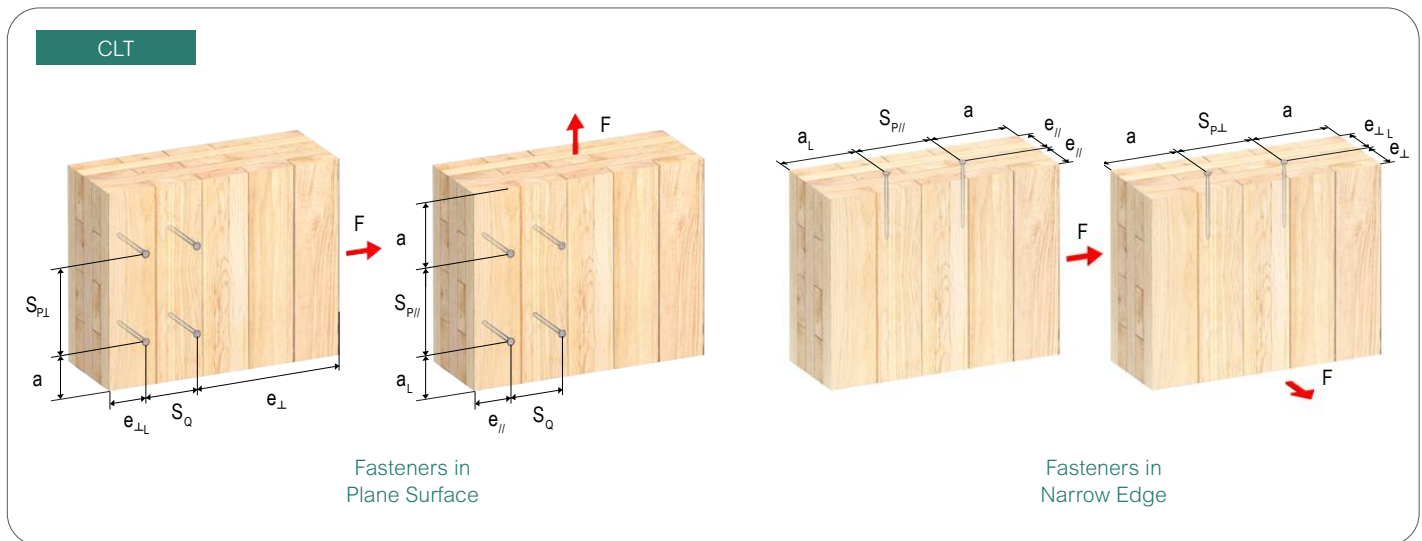

3.6 - Geometry Requirements for Fully Threaded Self-Tapping Screws for CLT

Loading Configuration		Installation Configuration		
		CLT [$G = 0.42$]		
		Self-Tapping Screws		
		Surface	Edge	
End Distance	Lateral loading parallel to grain in tension	a_L	6D	12D
	Lateral loading parallel to grain in compression	a	6D	7D
	Lateral loading perpendicular to grain	a	6D	7D
	Axial loading	a_{axial}	6D	7D
Edge Distance	Lateral loading parallel to grain	e_{\parallel}	2.5D	3D
	Lateral loading perpendicular to grain, toward edge	$e_{\perp L}$	6D	6D
	Lateral loading perpendicular to grain, away from edge	e_{\perp}	2.5D	3D
	Axial loading	e_{axial}	2.5D	3D
Spacing Between Fasteners in a Row [parallel to grain]	Lateral loading parallel to grain	$S_{P\parallel}$	4D	10D
	Lateral loading perpendicular to grain	$S_{P\perp}$	4D	10D
	Axial loading	$S_{P\ axial}$	4D	10D
Spacing Between Rows [perpendicular to grain]	Lateral loading parallel to grain	S_Q	2.5D	4D
	Axial loading	$S_{Q\ axial}$	2.5D	4D

Notes:

- All connection design must meet all the relevant requirements outlined in the General Notes to the Designer section.
- For species prone to splitting (e.g., Douglas Fir and Hem-Fir), it is recommended that the parallel-to-grain spacing requirements be increased by 50%.
- Within a row, fasteners may be staggered up to 2D to further reduce the potential for splitting.
- The listed values are applicable when the CLT panel thickness is at least 10D.
- The minimum penetration length of the screw into the narrow face of the panel shall be 10D.
- The geometry requirements are derived in accordance with ETA-11/0190.
- The minimum geometry requirements outlined in this table are meant to provide sufficient end and edge distances, as well as spacings between fasteners, to reduce the potential for splitting.
- Applying the minimum requirements does not prevent wood failure, such as row tear-out, group tear-out, block tear-out, net tension failure, or splitting perpendicular to grain.



Bow River Pedestrian Bridge

Banff, Alberta

Stainless Steel Fastener Series

MTC Solutions stainless steel self-tapping Partially Threaded fasteners are versatile screws used for connections in wet service conditions. For more information, read the Service Condition & Corrosion section.



∅ · 1/4 in. [6 mm]
· 5/16 in. [8 mm]

ℓ · 2-3/8 in. to 11-7/8 in. [60 mm to 300 mm]



Engineered Heads



Countersunk Head



Washer Head



Ring Threaded Tip

Reduces the need for predrilling and provides the quickest fastener wood bite



Stainless Steel

Stainless steel fasteners for use in wet service conditions



Large Threads

Provides high withdrawal resistance

CERTIFICATIONS



ICC
EVALUATION
SERVICE

ICC-ESR-3179

ISO 50001

Energy
Management
System



ETA-11/0190

Product Overview

ASSY A2 Ecofast

Countersunk-Head Self-Tapping Wood Screw

The ASSY A2 Ecofast stainless steel fasteners are ideal for exterior projects, delivering a clean and flush architectural finish. Applications include outdoor fencing, rails, solar panels, cladding, fascia board, strapping, and decking.



Countersunk Head with Milling Pockets



Ring Thread Tip



Suitable in Wet Service Conditions



Certifications	ICC-ESR-3179, ETA-11/0190
Connection Types	Wood to Wood, Steel to Wood
Corrosion Resistance	High (refer to page 16)

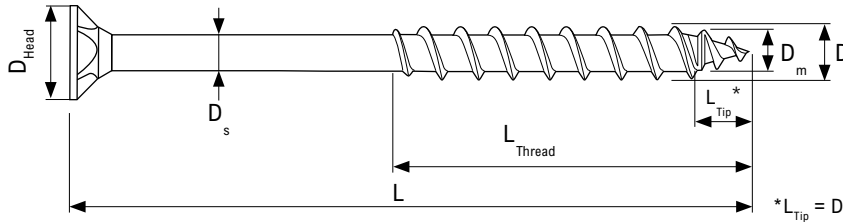

ASSY A2 Ecofast - 1/4 in. [6 mm] & 5/16 in. [8 mm] DIAMETERS

Specification Item #	Packaging Qty.	D	L	L _{Thread}	D _{Head}	D _m	D _s	Driver Bit
		in. [mm]	in. [mm]	in. [mm]	in. [mm]			
A2ECO0660	200	1/4 [6]	2-3/8 [60]	1-1/2 [37]	0.472 [12]	0.154 [3.9]	0.173 [4.4]	RW 30
A2ECO0680	100		3-1/8 [80]	2 [50]				
A2ECO06100	100		4 [100]	2-3/8 [60]				
A2ECO06120	100		4-3/4 [120]	2-3/4 [70]				
A2ECO06140	100		5-1/2 [140]	2-3/4 [70]				
A2ECO0880	75	5/16 [8]	3-1/8 [80]	2 [50]	0.591 [15]	0.197 [5]	0.234 [5.95]	RW 40
A2ECO08100	75		4 [100]	2-3/8 [60]				
A2ECO08120	75		4-3/4 [120]	3-1/8 [80]				
A2ECO08140	75		5-1/2 [140]	3-1/8 [80]				
A2ECO08160	75		6-1/4 [160]	3-1/8 [80]				
A2ECO08180	75		7-1/8 [180]	3-1/8 [80]				
A2ECO08200	75		7-7/8 [200]	3-1/8 [80]				
A2ECO08220	75		8-5/8 [220]	4 [100]				
A2ECO08240	75		9-1/2 [240]	4 [100]				
A2ECO08260	75		10-1/4 [260]	4 [100]				
A2ECO08280	75		11 [280]	4 [100]				
A2ECO08300	75	11-7/8 [300]	4 [100]					

ASSY A2 SK

Washer-Head Self-Tapping Wood Screw

The ASSY A2 SK stainless steel fasteners are ideal for exterior wood-to-wood applications requiring a high head pull-through capacity. Applications include exposed timber frame structures, carpentry, and boardwalks.



Washer Head



Ring Thread Tip



Suitable in Wet Service Conditions

Certifications	ICC-ESR-3179, ETA-11/0190
Connection Types	Wood to Wood
Corrosion Resistance	High (refer to page 16)

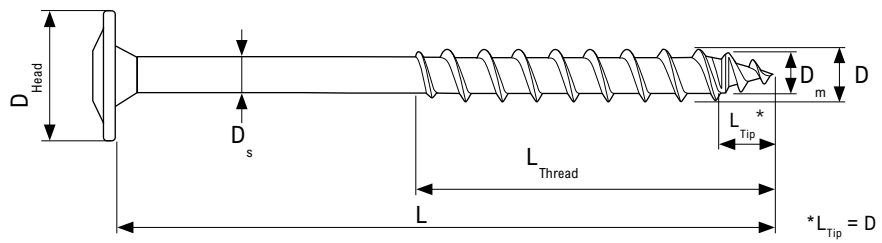
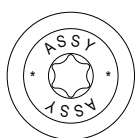

ASSY A2 SK - 1/4 in. [6 mm] & 5/16 in. [8 mm] DIAMETERS

Specification	Packaging Qty.	D	L	L _{Thread}	D _{Head}	D _m	D _s	Driver Bit
Item #		in. [mm]	in. [mm]	in. [mm]	in. [mm]			
A2SK0680	100	1/4 [6]	3-1/8 [80]	2 [50]	0.551 [14]	0.154 [3.9]	0.173 [4.4]	RW 30
A2SK06100	100		4 [100]	2-3/8 [60]				
A2SK06120	100		4-3/4 [120]	2-3/4 [70]				
A2SK06140	100		5-1/2 [140]	2-3/4 [70]				
A2SK08100	50	5/16 [8]	4 [100]	2-3/8 [60]	0.739 [18.9]	0.197 [5]	0.234 [5.95]	RW 40
A2SK08120	50		4-3/4 [120]	3-1/8 [80]				
A2SK08140	50		5-1/2 [140]	3-1/8 [80]				
A2SK08160	50		6-1/4 [160]	3-1/8 [80]				
A2SK08180	50		7-1/8 [180]	3-1/8 [80]				
A2SK08260	50		10-1/4 [260]	4 [100]				
A2SK08300	50		11-7/8 [300]	4 [100]				

Reference Design Values

4.1 - Reference Withdrawal Design Values, W_{90} , for Stainless Steel Fastener Series

Diameter [in.]	W_{90} [lb./in.]	
	Specific Gravity [G]	
	G = 0.42	G = 0.49
1/4	143	162
5/16	169	211

- Notes:
- Reference design values presented in this table are based on the ICC-ESR-3179 (2024)
 - Tabulated reference withdrawal design values, W_{90} , apply to screws installed perpendicular to the grain of the wood member. For screws installed at an angle to the wood grain, W_{90} shall be reduced by the appropriate angle-to-grain reduction factor, R_{α} , to obtain the applicable angle-to-grain withdrawal design value [see eq. 1].
 - G refers to the specific gravity assigned to the wood species.
 - Connection design must meet all relevant requirements of the General Notes to the Designer section.

4.2 - Reference Head Pull-Through Design Values, W_H , for Stainless Steel Fastener Series

Diameter [in.]	Fastener Type	W_H [lb.]				
		Specific Gravity [G]				
		Lumber & Glulam				PSL ESG \geq 0.50
		G = 0.35	G = 0.42	G = 0.49	G = 0.55	
1/4	A2 Ecofast	133	163	194	221	262
	A2 SK	244	299	356	407	440
5/16	A2 Ecofast	187	232	277	318	327
	A2 SK	—	445	524	—	—

- Notes:
- Reference design values presented in this table are based on ICC-ESR-3179 (2024).
 - Design values are applicable to connections with a wood side member thickness of at least 1-3/8 in.
 - Connection design must meet all relevant requirements of the Notes to the Designer section.
 - Tabulated head pull-through design values, W_H , are applicable to screws installed perpendicular to the faces of the wood members and must be multiplied by all adjustment factors included in NDS 2024 for dowel-type fasteners to determine allowable loads for use with ASD and/or design loads for use with LRFD [see eq. 2].

4.3 - Fastener Strength Values For Stainless Steel Fastener Series

Diameter [in.]	Bending Yield Strength, F_{yb} [psi]	Tensile Strength, T_s [lb.]		Shear Strength, V [lb.]		Allowable Insertion Torque [lb.·ft]
		ASD	LRFD	ASD	LRFD	
1/4	99,900	600	900	450	675	3.1
5/16	99,500	1,170	1,755	915	1,375	7.9

- Notes:
- Connection design must meet all relevant requirements of the General Notes to the Designer section.
 - Bending yield strength is determined in accordance with ASTM F1575 using the minor diameter of the fastener.
 - The allowable insertion torque is determined in accordance with EAD 130118-01-0603, where the ratio of torsional strength to insertion torque should be at least 1.5.
 - Specified bending yield strength, tensile resistance, and shear strength values presented in this table are based on ICC-ESR-3179 (2024).

Geometry Requirements

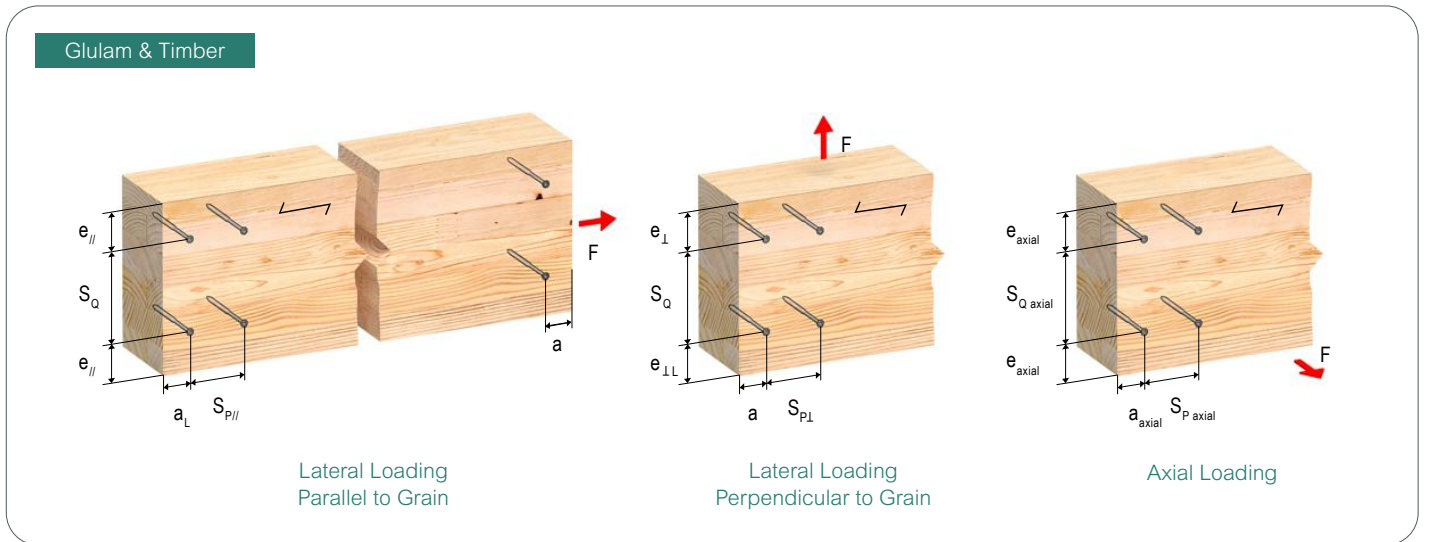

4.4 - Geometry Requirements for Stainless Steel Self-Tapping Screws for Glulam and Timber

Loading Configuration			Installation Configuration		
			Glulam & Timber		
			Self-Tapping Screws		Predrilling
			G < 0.5	G ≥ 0.5	Any G
End Distance	Lateral loading parallel to grain in tension	a_L	15D*	20D	7D
	Lateral loading parallel to grain in compression	a	10D*	15D	4D
	Lateral loading perpendicular to grain	a	10D*	15D	4D
	Axial loading	a_{axial}	10D*	10D	4D
Edge Distance	Lateral loading parallel to grain	$e_{ }$	5D	7D	3D
	Lateral loading perpendicular to grain, toward edge	$e_{\perp L}$	10D	12D	4D
	Lateral loading perpendicular to grain, away from edge	e_{\perp}	5D	7D	4D
	Axial loading	e_{axial}	4D	4D	3D
Spacing between Fasteners in a Row [parallel to grain]	Lateral loading parallel to grain	$S_{P }$	15D*	15D	4D
	Lateral loading perpendicular to grain	$S_{P\perp}$	10D*	10D	4D
	Axial loading	$S_{P_{axial}}$	7D*	7D	4D
Spacing between Rows [perpendicular to grain]	Lateral loading parallel to grain	S_Q	5D	7D	5D
	Lateral loading; staggered rows	S_{QS}	2.5D	3D	—
	Axial loading ($D \leq 5/16"$)	$S_{Q_{axial}}$	4D	4D	4D
	Axial loading ($D > 5/16"$)	$S_{Q_{axial}}$	5D	5D	4D

* For species prone to splitting, including Douglas Fir-Larch, minimum geometry requirements may need to be increased.

- Notes:
- All connection design must meet all the relevant requirements outlined in the General Notes to the Designer section.
 - Values for spacing between staggered rows apply where fasteners in adjacent rows are offset by half of the spacing between fasteners in a row.
 - Within a row, fasteners may be staggered up to 2D to further reduce the potential for splitting.
 - The geometry requirements for staggered rows are per ESR 3179. All remaining geometry requirements are per NDS 2024 Section 12.5.1.
 - The minimum geometry requirements outlined in this section are meant to provide sufficient end and edge distances, as well as spacings between rows and between fasteners in a row, to reduce the potential for splitting.
 - Applying the minimum requirements does not prevent wood failure, such as row tear-out, group tear-out, block tear-out, net tension failure, or splitting perpendicular to grain.



North Surrey Sport & Ice Complex

Surrey, British Columbia

Self-Drilling Dowels

MTC Solutions Self-Drilling Dowels are cylinder-head dowel fasteners designed for timber connections with knife plates. It can be used in various connection scenarios such as timber moment connections, custom beam hangers, and hold-down connections, where internal steel plates are used for shear load transmission.



∅ · 0.27 in. [6.9 mm]

ℓ · 2-7/8 in. to 9-1/8 in. [73 mm to 233 mm]

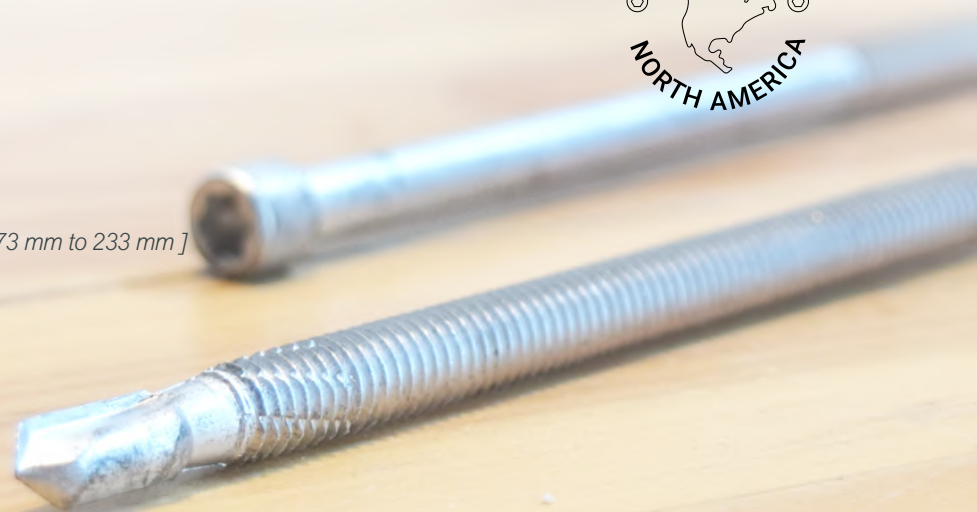

Engineered Head



Cylinder Head



Case-Hardened Steel

A ductile core with increased outer surface hardness, providing high bending yield strength & ductility



Coated Steel

Fasteners with a high-grade zinc-aluminum flake coating for use in dry service conditions



Continuous Thread

Helps prevent the dowel from slipping out of the knife plate, especially when loaded cyclically



Drilling Tip

Drilling tip reduces the need for predrilling in wood and thin metal plates. Predrilling is recommended for thicker (> 1/8 in.) knife plates and connections with multiple knife plates

Product Overview

Self-Drilling Dowel

Cylinder-Head Fastener for Internal Knife Plate Connections

The Self-Drilling Dowel (SDD) is engineered to be used in multiple connection scenarios where internal steel plates are used for load transmission. The dowel head is perfect for concealed connections, and the continuous threads keep the fastener secured in the metal plate. The SDD is suitable for use in dry service conditions only.



Cylinder Head



Continuous Thread



Drilling Tip

Connection Types	Internal Steel Plate to Wood
Corrosion Resistance	Regular (refer to page 16)

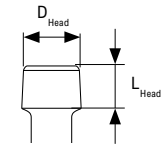
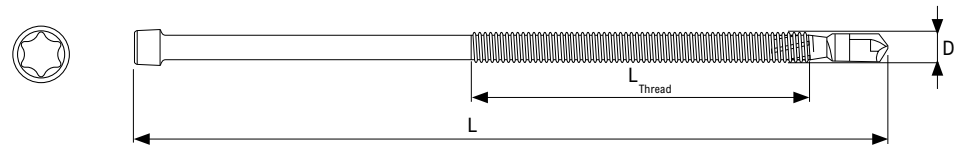

Self-Drilling Dowel - 0.27 in. [6.9 mm] DIAMETER

Specification	Packaging Qty.	D	L	L _{Thread}	D _{Head}	L _{Head}	Drive Bit
Item #		in. [mm]	in. [mm]	in. [mm]	in. [mm]	in. [mm]	
SDD0673	50	0.27 [6.9]	2-7/8 [73]	1-1/4 [31]	0.394 [10]	0.295 [7.5]	RW 40
SDD0693	50		3-5/8 [93]	1-5/8 [40]			
SDD06113	50		4-1/2 [113]	2 [50]			
SDD06133	50		5-1/4 [133]	2-3/8 [60]			
SDD06153	50		6 [153]	2-3/4 [70]			
SDD06173	50		6-3/4 [173]	3-1/8 [80]			
SDD06193	50		7-5/8 [193]	3-1/2 [90]			
SDD06213	50		8-3/8 [213]	3-7/8 [100]			
SDD06233	50		9-1/8 [233]	4-3/8 [110]			

Specified Strength Values

5.1 - Specified Strength Values for Self-Drilling Dowels

Diameter, D [in.]	Bending Yield Strength, F _{yb} [psi]	Specified Shear Resistance, V [lb.]	Allowable Insertion Torque [lb.-ft]
		LRFD	
0.27	126,200	2,590	28.6

Notes:

1. Connection design must meet all relevant requirements outlined in the General Notes to the Designer section.
2. The allowable insertion torque is determined in accordance with EAD 130118-01-0603, where the ratio of torsional strength to insertion torque should be at least 1.5.

Geometry Requirements

Glulam & Timber

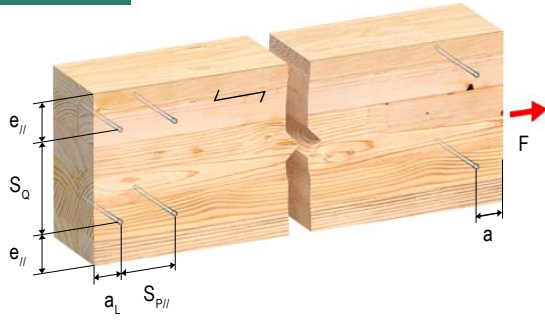

Lateral Loading
Parallel to Grain

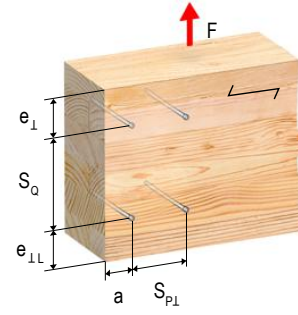

Lateral Loading
Perpendicular to Grain

CLT

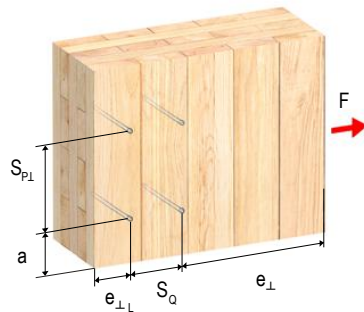

Fasteners in
Plane Surface

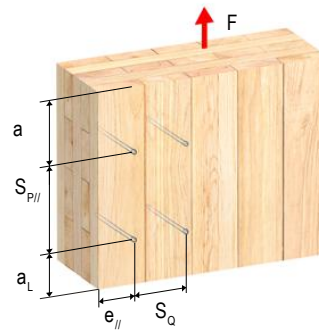

5.2 - Geometry Requirements for Self-Drilling Dowels

Loading Configuration		Installation Configuration	
		Glulam, Timber, & CLT Face [Any G]	
End Distance	Lateral loading parallel to grain in tension	a_L	7D
	Lateral loading parallel to grain in compression	a	4D
	Lateral loading perpendicular to grain	a	4D
Edge Distance	Lateral loading parallel to grain	$e_{ }$	3D
	Lateral loading perp. to grain, toward edge	$e_{\perp L}$	4D
	Lateral loading perp. to grain, away from edge	e_{\perp}	1.5D
Spacing Between Fasteners in a Row [parallel to grain]	Lateral loading parallel to grain	$S_{P }$	4D
	Lateral loading perpendicular to grain	$S_{P\perp}$	3D
Spacing Between Rows [perpendicular to grain]	Lateral loading parallel to grain	S_Q	1.5D
	Lateral loading perpendicular to grain	$S_{Q\perp}$	5D

Notes:

- All connection design must meet all the relevant requirements outlined in the General Notes to the Designer section.
- In wood species sensitive to splitting, it may be necessary to increase the minimum geometry requirements.
- The listed values are applicable when the CLT panel thickness is at least 10D.
- The listed values are per NDS 2024 Section 12.5.1.
- The minimum geometry requirements outlined in this section are meant to provide sufficient end and edge distances, as well as spacings between rows and between fasteners in a row, to reduce the potential for splitting.
- Applying the minimum requirements does not prevent wood failure such as row tear-out, group tear-out, block tear-out, net tension failure, or splitting perpendicular to grain.



Wood Innovation and Design Centre

Prince George, British Columbia

Accessories

90° Cup Washer

Cost-Reducing Solution for Steel-to-Wood Connections

The 90° Cup Washer is a machined steel part designed for use with countersunk-head screws ASSY Ecofast and ASSY VG CSK. The washer provides proper bearing for the screw head in steel-to-wood connections, eliminating the need for reaming out the steel plate.



Designed for Countersunk-Head Fasteners

Connection Types Steel to Wood



Countersunk Head

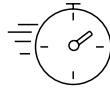

Fast Installation

1/4 in., 5/16 in., and 3/8 in. Cup Washer Dimensions

Nominal Fastener Diameter [D]	d_1	OD	h	al	d_2	d_3
in. [mm]				°	in. [mm]	
1/4 [6]	0.252 [6.4]	0.866 [22]	0.177 [4.5]	45	0.551 [14]	0.591 [15]
5/16 [8]	0.331 [8.4]	0.984 [25]	0.197 [5]	41	0.669 [17]	0.709 [18]
3/8 [10]	0.409 [10.4]	1.181 [30]	0.276 [7]	37	0.787 [20]	0.827 [21]

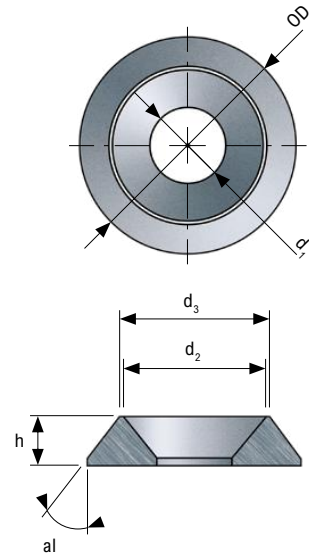

Note:

- The dimensions of the steel plate holes are provided in Appendix C: Steel Plate Detailing (Page 76).

1/2 in. Cup Washer Dimensions

Nominal Fastener Diameter [D]	d_1	OD	h	t_{wf}	d_2	h_p
in. [mm]						
1/2 [12]	0.492 [12.5]	1.654 [42]	0.197 [5]	0.157 [4]	0.906 [23]	0.118 [3]

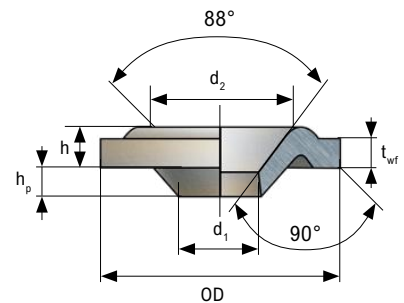

Note:

- The diameter of the steel plate holes should be equal to D_3 (refer to fastener specification pages).

45° Wedge Washer

Cost-Reducing Solution for Steel-to-Wood Connections

The 45° Wedge Washer, when paired with a predrilling jig, offers a cost-reducing solution for steel-to-wood connections using ASSY Ecofast and ASSY VG CSK screws. The wedge washer is inserted into a simple punched or machined slotted hole. Its use eliminates the need for predrilled inclined countersunk holes in steel plates and only requires standard slotted holes, resulting in cost reductions.



Designed for	Countersunk-Head Fasteners
Connection Types	Steel to Wood

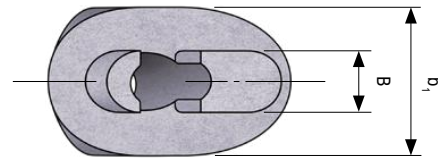
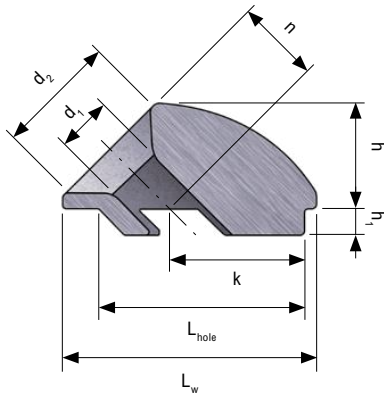
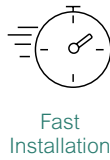

45° Washer Dimensions

Nominal Fastener Diameter [D]	d ₁	d ₂	L _w	b ₁	h	h ₁	B	L _{hole}	k	n	Steel Plate Thickness	
											Min.	Max.
in.												
[mm]												
5/16 [8]	0.335 [8.5]	0.748 [19]	1.535 [39]	0.945 [24]	0.630 [16]	0.142 [3.6]	0.390 [9.9]	1.248 [31.7]	0.827 [21]	0.500 [12.7]	0.157 [4]	0.591 [15]
3/8 [10]	0.421 [10.7]	0.945 [24]	2.047 [52]	1.142 [29]	0.843 [21.4]	0.185 [4.7]	0.425 [10.8]	1.720 [43.7]	1.130 [28.7]	0.724 [18.4]	0.197 [5]	0.787 [20]
1/2 [12]	0.500 [12.7]	1.024 [26]	2.323 [59]	1.181 [30]	0.925 [23.5]	0.22 [5.6]	0.504 [12.8]	1.957 [49.7]	1.339 [34]	0.780 [19.8]	0.236 [6]	0.984 [25]

Note:

- For coated steel plates, the hole needs to be oversized in order to account for the thickness of the coating. Test fitting of wedge washers into steel plate holes is required to ensure that the tolerances are met.

45° Washer Steel Plate Hole Dimensions

Nominal Fastener Diameter [D]	B		L _{hole}	
	Min.	Max.	Min.	Max.
in.				
[mm]				
5/16 [8]	0.394 [10]	0.433 [11]	1.260 [32]	1.299 [33]
3/8 [10]	0.441 [11]	0.472 [12]	1.732 [44]	1.772 [45]
1/2 [12]	0.512 [13]	0.551 [14]	1.969 [50]	2.008 [51]

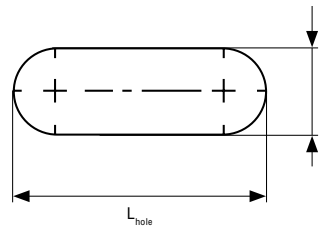

Predrilling Jig

Eases Predrilling for Inclined Fasteners

The Predrilling Jig ensures precise alignment for fasteners in steel-to-wood connections, especially where the head is countersunk into a steel plate or washer, minimizing the risk of off-center and off-axis installation. By guiding the drill bit to create accurate pilot holes, it guarantees optimal fastener seating and helps to ensure the overall strength of the connection. The inner diameters, d, accommodate standard imperial and metric drill bit diameters recommended for predrilling and are available in three sizes:

- **3/16 in.** [5 mm]
- **1/4 in.** [6 mm]
- **9/32 in.** [7 mm]

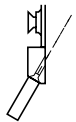

RICON XL
Compatible

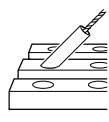

MEGANT
Compatible

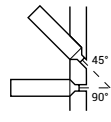

45° & 90° Steel Plate
Compatible



Bits

Patented Bits for ASSY Fasteners

The ASSY RW bit is a hardened bit designed for quick and efficient installation of ASSY fasteners. Suitable bits for each fastener are listed in its specification table.



Snug
Fit



Reduced
Wobbling



Optimum Torque
Transfer



RW 30



RW 40



RW 50

Magnetic Hex Socket

Accessory for Installing ASSY Kombi Screws

The magnetic socket can be used for faster installation of the ASSY Kombi screws. The built-in magnet makes it easy to place and hold the screw head inside the socket before installation. The magnetic socket is suitable for use with most low-RPM, high-torque drills that are used for the installation of ASSY self-tapping screws.



Hex Head

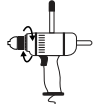

Suitable for Double Handle Drill



Optimum Torque Transfer

Bit Holder Socket

Bit Holder Socket for RW 50 Bits

The Bit Holder Socket is designed to hold the RW 50 bits on large double handle drills. The socket can be used with the magnetic bit holder case to facilitate the installation of larger-diameter screws, which requires higher torque. The Bit Holder Socket is meant to be used with the Magnetic Bit Case Holder SK, VG CSK.

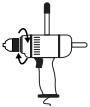

Suitable for Large Drills



RW 50 Compatible



Optimum Torque Transfer

Reverse-Head Socket

Accessory for Installing ASSY VG RH Screws

The Reverse-Head Socket is a special driver bit for ASSY VG RH screws, providing a snug fit for their head type and thus easily transferring the high torque required for installation. This socket is designed for use in conjunction with the associated Magnetic Bit Case Holder.



Reverse Head



Snug Fit



Optimum Torque Transfer

Magnetic Bit Case Holder VG RH

Eases Installation of ASSY VG RH Screws

Using the built-in magnet, the Bit Case Holder holds the screw and bit in place at the start of installation, before the threads have engaged with the wood fiber. Therefore, the Bit Case Holder can be used for a more efficient overhead installation. It is designed for use with the Reverse-Head Socket for ASSY VG RH screws, simplifying their installation.



Reverse
Head



Efficient
Overhead Installation



Magnetic

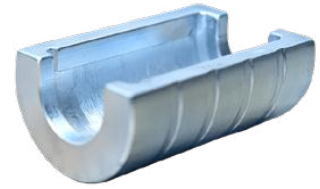

Magnetic Bit Case Holder SK, VG CSK

Eases Installation of ASSY SK and VG CSK Screws

The Magnetic Bit Case Holder is designed for use with the Bit Holder Socket for RW 50 bits for installation of ASSY SK and VG CSK screws. Using the built-in magnet, the Bit Case Holder secures the screw and the RW bit together to hold the connection in place during installation.



Countersunk
Head



Efficient
Overhead Installation



Magnetic





Kingsway Royal Alex LRT Stations

Edmonton, Alberta

Appendix

APPENDIX A: GENERAL CONNECTION INFORMATION	76
Main and Side Members	76
Fastener Angle Notation	76
Lateral Connections	77
Brittle Failure Modes in Wood	78
APPENDIX B: ADDITIONAL GEOMETRY CONSIDERATIONS	79
Wood Members at an Angle	79
Forces at an Angle to Grain	79
End and Edge Distance Requirements for Reinforcing Screws	79
Screws Reinforcing Connections Loaded Perpendicular to Grain	80
Screws Reinforcing Connections Loaded Parallel to Grain	80
Geometry Requirements for Inclined Fully Threaded Screws	81
Inclined Screws in Reverse Loading	81
Geometry Requirements for Toe Screws	82
Geometry Requirements for Screw Crosses	82
Brittle Failure Modes Related to Axially Loaded Screws	83
Inclined Screws in Three-Member Connections	83
APPENDIX C: STEEL PLATE DETAILING	84
Steel-to-Wood Connection Detailing	84
APPENDIX D: SERVICE CONDITIONS AND DURABLE DESIGN	86
Service Conditions and Other Factors Impacting Corrosion	86
Other Fastener Degredation Mechanisms	89
Design and Detailing Considerations for Durability	90
APPENDIX E: INSTALLATION GUIDELINES	95
General Installation Instructions	95
Predrilling and Pilot Holes	97
Fastener Installation in Steel Side Plates	98

Appendix A: General Connection Information

Main and Side Members

In timber design, the main member is typically the primary structural element into which the tip of the screw penetrates, while the side member is the element being attached, where the screw head is located. For partially threaded screws, selecting a length that ensures threads are only embedded in the main member helps maintain optimal connection strength and allows the connection to be properly tightened.

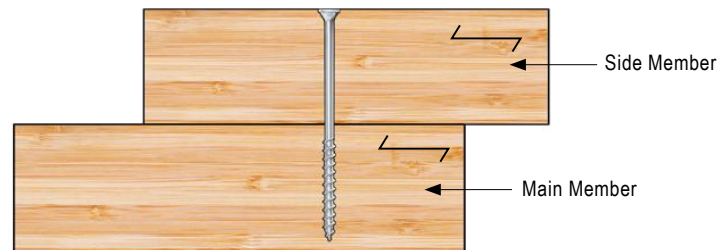

Two-Member Connection

Fastener Angle Notation

Two angle parameters for connections are defined as follows:

- α represents the relative angle between the fastener axis and the grain orientation
- β represents the smallest angle between the fastener axis and the shear plane

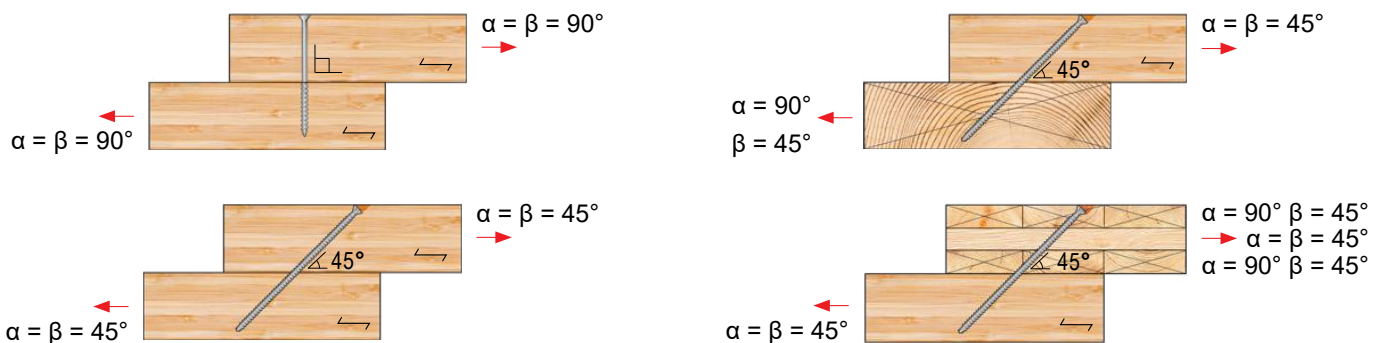

Angle Parameters for Various Configurations

Lateral Connections

Lateral connections can be designed for ductile failure modes. To ensure ductile behavior, a connection should be designed in such a way that fastener yielding is the governing failure mode. Additionally, the designer should perform appropriate checks to avoid brittle failure modes in the wood.

Fastener Yield Modes

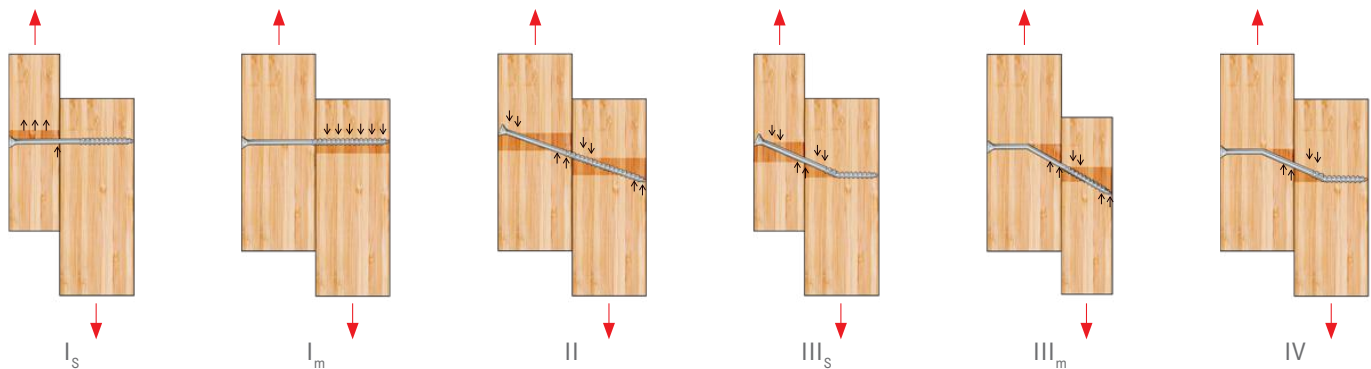

NDS Yield Modes for Two-Member Connections

As illustrated above for two-member connections, fastener yield modes are primarily a function of the embedment failure in the wood member or yielding failure of the fastener, or a combination of both.

Self-tapping screws have a higher bending yield strength, F_{yb} , compared to traditional lag screws. These F_{yb} values are provided in the reference design value tables for different series of MTC Solutions fasteners. With self-tapping screws, Yield Modes III_s and IV are the most desirable yielding mechanisms as they offer high ductility. This is especially true for CLT diaphragm design where lateral capacity is required to be governed by Mode III_s or IV according to the 2021 Special Design Provisions for Wind and Seismic (SDPWS). As a rule of thumb, a lateral connection typically reaches Yield Mode IV at a minimum penetration length of 8D based on the NDS 2024 yield equations. Increasing the penetration length beyond this point does not result in increased lateral capacity according to these equations, as the fastener will have yielded in both members.

Brittle Failure Modes in Wood

For connections with multiple closely spaced large-diameter fasteners, the resistance might be limited by wood brittle failure modes due to tension and/or shear failure in parts of the wood members surrounding the fasteners before each fastener reaches its bearing capacity in the group. These failures can occur in parallel- or perpendicular-to-grain loading directions. Common brittle failure modes that need to be checked for large dowel-type fasteners include, but are not limited to:

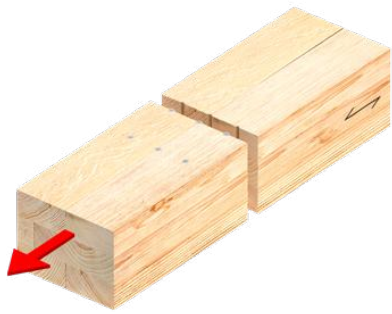

Net Tension Failure Mode

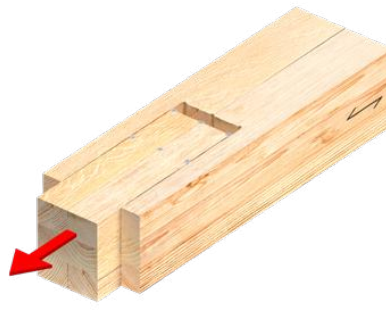

Group Tear-Out Failure Mode

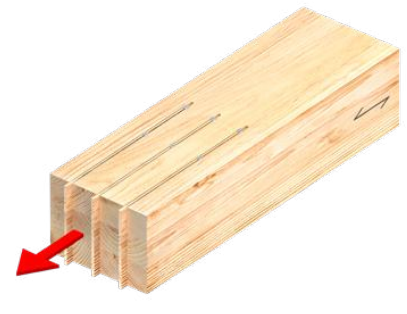

Row Shear Failure Mode

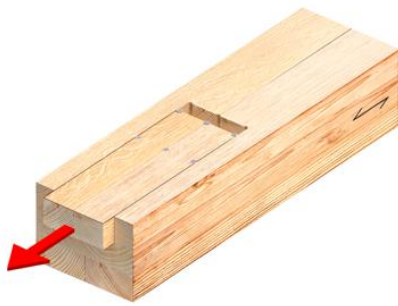

Plug Shear Failure Mode

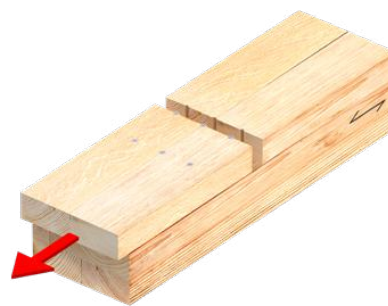

Step Shear Failure Mode

Brittle Failures in Parallel-to-Grain Loading per CSA O86:24 Clause 12.12.10.7

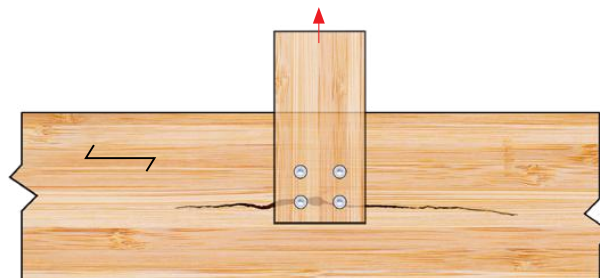

Splitting Failure in Perpendicular-to-Grain Loading

The minimum fastener spacing, edge distance, and end distance requirements specified elsewhere in this document are intended to prevent splitting of wood that can occur during installation of closely spaced fasteners. A fastener layout that conforms to the minimum spacing and end/edge distance requirements does not ensure adequate strength to preclude brittle failure modes from occurring when wood member connections are loaded. Designers must ensure that members connected with self-drilling dowels or self-tapping screws conform to the principles of engineering mechanics. Appendix E in NDS 2024 provides one method for evaluating these types of failures.

Appendix B: Additional Geometry Considerations

Wood Members at an Angle

In cases where fasteners are installed in members with miter cuts, the corresponding end and edge distances are measured along and across the grain, respectively.

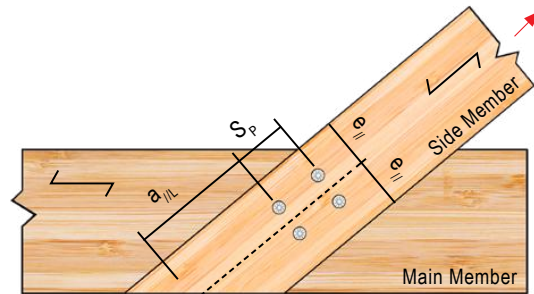

Wood Member at an Angle

Forces at an Angle to Grain

The direction of the force applied to the fastener must be considered when identifying loaded ends and edges.

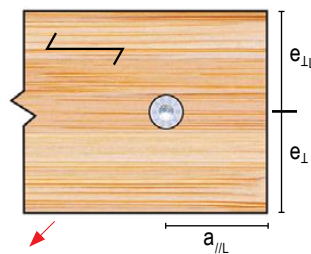

Wood Member Loaded at an Angle

End and Edge Distance Requirements for Reinforcing Screws

Reinforcing screws should be placed as close to the expected location of peak stress application as possible. Minimum end and edge distances still apply.

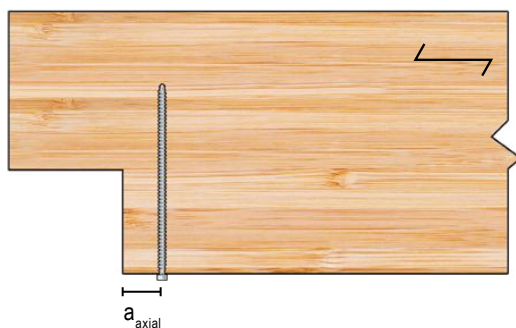

End Distance Requirements for Reinforcing Screws

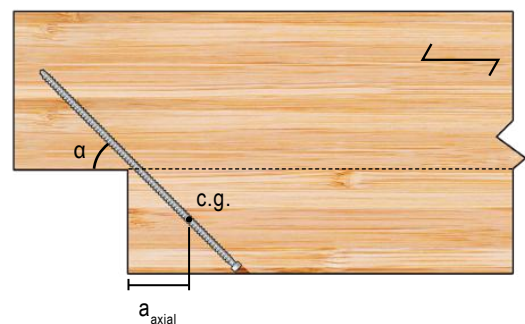

Note: c.g. is the center of gravity of the screw below the fracture point.

End Distance Requirements for Inclined Reinforcing Screws

Screws Reinforcing Connections Loaded Perpendicular to Grain

For the connection type shown in the figure below, reinforcing screws should be placed as close to the origin of stress cracking as possible. Maintaining a minimum screw spacing of $1.5D$ may help to prevent screw collision. The screw spacing follows the usual geometry requirements for axially loaded fasteners. To ensure accurate installation, a pilot hole may be required along the desired fastener path.

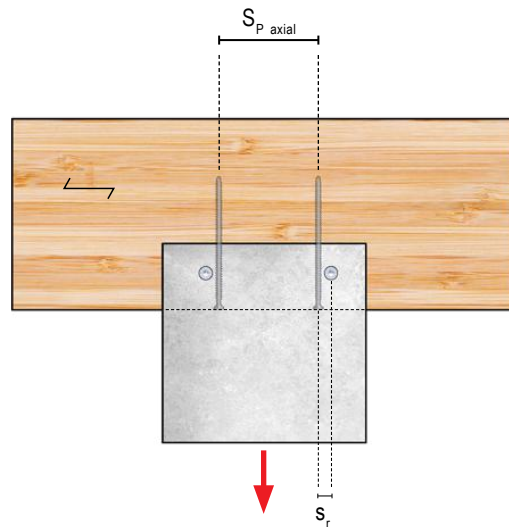

Geometry Requirements for Screws Reinforcing Bolted Connections Loaded Perpendicular to Grain

Screws Reinforcing Connections Loaded Parallel to Grain

Reinforcing screws should be placed as close to the origin of stress cracking as possible, i.e., s_r should be minimized. A minimum distance of $1.5D$ should be provided between the reinforcing screws and the other dowel-type fasteners ($s_r > 1.5D$), provided that the respective axes are oriented perpendicular to each other and that there is no screw collision. To be effective, reinforcing screws must be placed on the same side of the bolt that bears against the wood member (as shown in the figure below) to resist splitting along the grain.

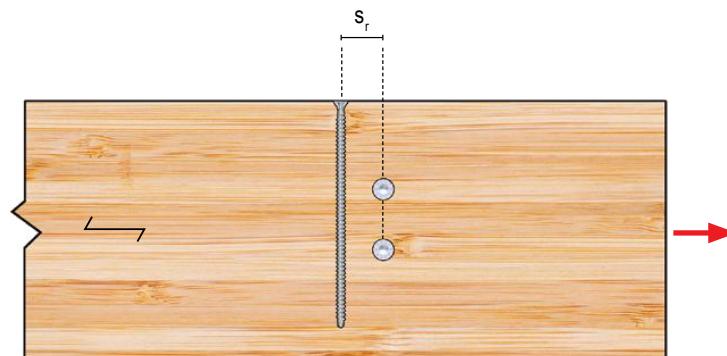

Geometry Requirements for Screws Reinforcing Bolt Connections Loaded Parallel to Grain

Geometry Requirements for Inclined Fully Threaded Screws

For inclined-screw connections, the center of gravity of the threaded portion of the screw, excluding the tip and unthreaded section in both the side and main members, C_s and C_m , respectively, is used when applying end and edge distance requirements in accordance with Tables 3.5 (Page 56) and 3.6 (Page 57).

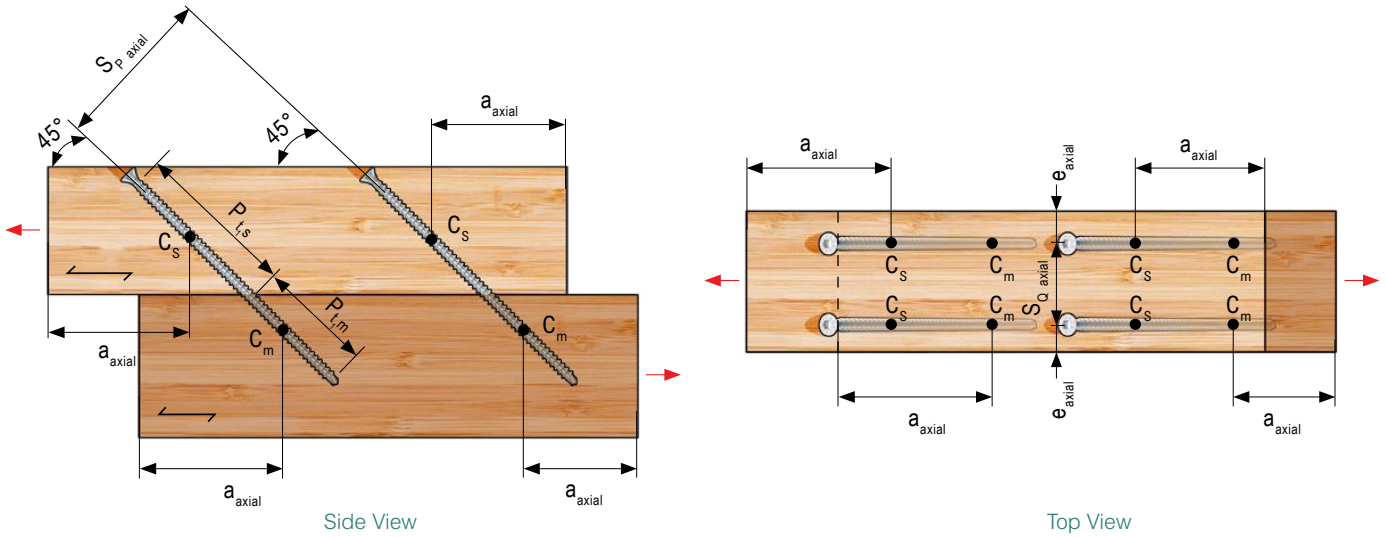

Inclined Screws in Reverse Loading

The inclined-screw configuration illustrated below is not recommended when the screw is in shear-compression, as it may lead to panel separation and screw bending due to uplift forces. For reverse loading or connections subjected to loads oriented in multiple directions, screw crosses are recommended as they offer more stability.

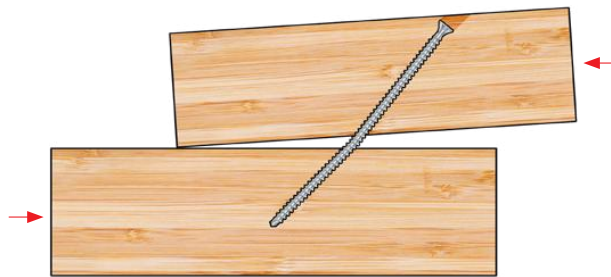

Inclined Screw in Reverse Loading

Geometry Requirements for Toe Screws

For toe screw connections, the center of gravity of the portion of the screw in each member is used when applying end and edge distance requirements. Swelling and shrinkage of wood members due to changes in moisture content should be considered for toe screw connections. Load eccentricities should be avoided to maintain connection stability. Additionally, toe screw connections should have a tight joint to develop compression, essential to effective function.

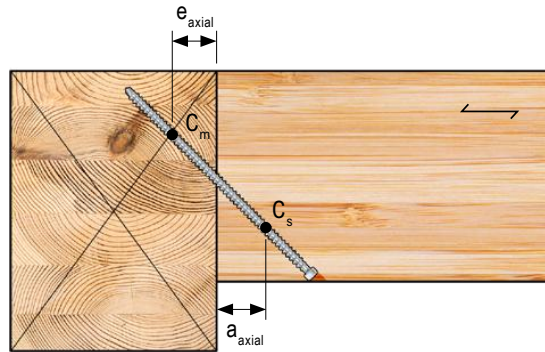

Geometry Requirements for Screw Crosses

Screws in a cross pair need to be offset from one another by at least $1.5D$ to accommodate installation tolerances and prevent collision.

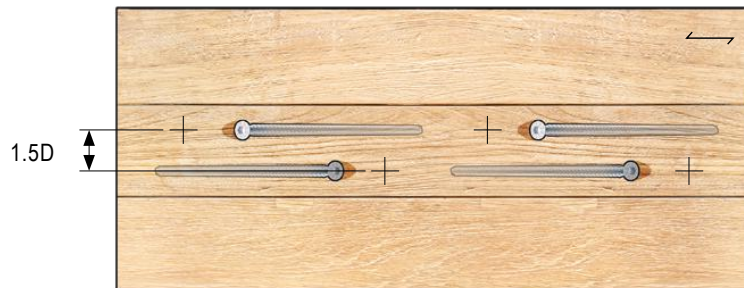

Top View

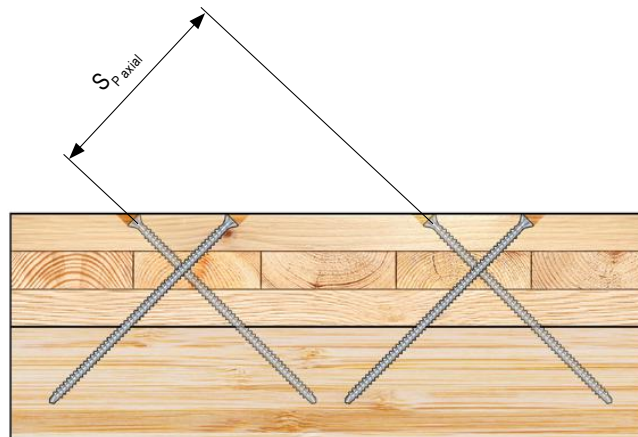

Side View

Fasteners acting as a pair should be installed at the same angle, opposite to each other, with the same thread penetration lengths in either member. Typically, the fasteners cross at either the central plane of the side member or at the shear plane between the two members. Fasteners crossing at the centroid of the side member should be preferred over those crossing at the shear plane, as the former minimizes loading eccentricities that can lead to connection instability.

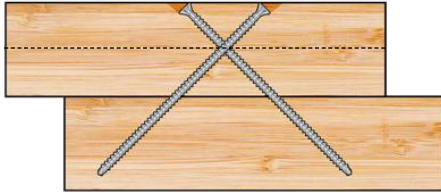

Fasteners Crossing at the Central Plane of the Side Member

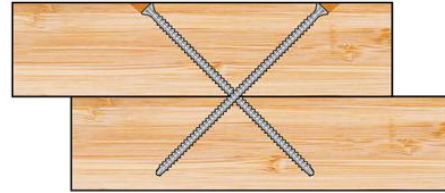

Fasteners Crossing at the Shear Plane

Brittle Failure Modes Related to Axially Loaded Screws

In two-member, steel-to-wood connections, there is a possibility of block shear failure, plug shear failure, or perpendicular-to-grain split failure as shown below, when the screw axis is parallel to the load direction. This failure mechanism depends on the screw spacings, effective thread penetration length, and the angles of the screw axis and loading direction with respect to the wood grain orientation. The worst-case scenario occurs at a 90° angle.

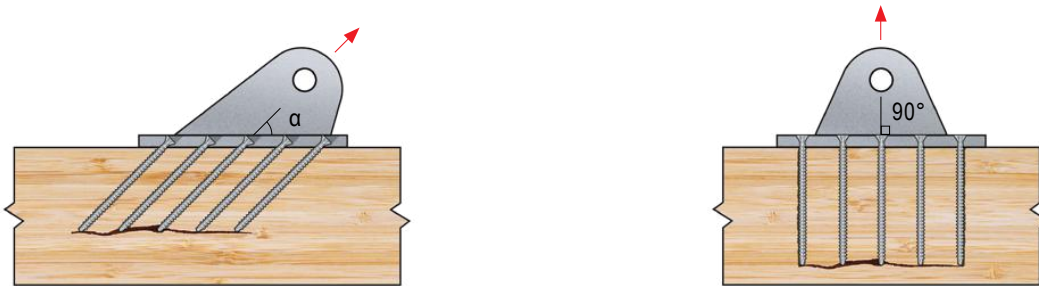

Splitting Failure Perpendicular to Grain in Steel-to-Wood Connections

Inclined Screws in Three-Member Connections

The loading configuration in the figure below (left) may cause splitting failure in wood. Therefore, such detailing should be avoided for symmetrical, three-member joints. If necessary, the screws in symmetrical joints should overlap by at least $4D$ (not including the tip).

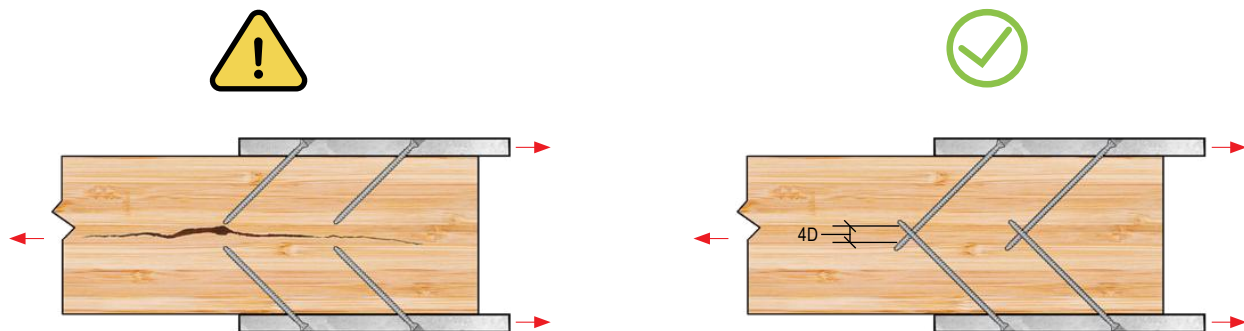

Inclined Screws in a Three-Member Connection

Appendix C: Steel Plate Detailing

Steel-to-Wood Connection Detailing

A steel-to-wood connection can be established with ASSY self-tapping fasteners using one of the following methods:

- Bear the fastener's head directly on the steel plate,
- Countersink the fastener head into the steel plate, or
- Install each fastener with a washer

ASSY Kombi and Kombi LT fasteners with hex heads are designed to provide a snug fit with their tapered shoulder in the steel side member. ASSY VG CSK and ASSY Ecofast fasteners with countersunk heads are reliable alternatives for steel-to-wood connections.

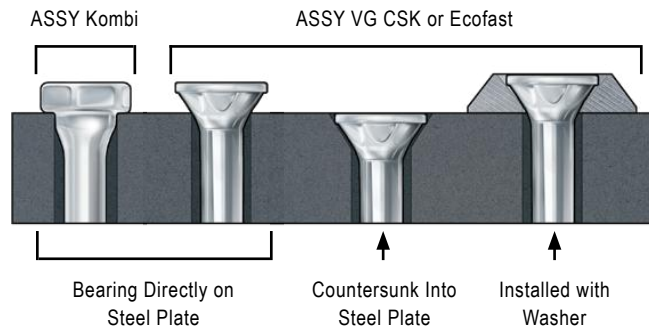

The steel side member must be predrilled prior to fastener installation. Steel plate holes are generally kept 1/16 in. [1 mm] larger than the nominal screw diameter, D. If a coating is present on the steel plate, holes must be oversized to account for the coating thickness.

Table C.1 - Countersunk Fastener Head and Shank Dimensions

Nominal Fastener Diameter [D]	Fastener Type	D _{head}	D _a	D _p	t _p	Drive Bit
		in. [mm]				
1/4 [6]	Ecofast	0.472 [12]	0.276 [7]	0.622 [15.8]	0.173 [4.4]	RW 40
5/16 [8]	Ecofast	0.591 [15]	0.354 [9]	0.748 [19]	0.197 [5]	
	VG CSK	0.591 [15]	0.354 [9]	0.748 [19]	0.197 [5]	
3/8 [10]	Ecofast	0.728 [18.5]	0.433 [11]	0.898 [22.8]	0.232 [5.9]	
	VG CSK	0.787 [20]	0.433 [11]	0.945 [24]	0.256 [6.5]	
1/2 [12]	VG CSK	0.866 [22]	0.512 [13]	1.039 [26.4]	0.264 [6.7]	

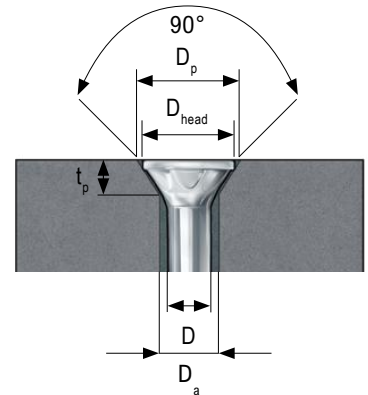

Table C.2 - Kombi Fastener Head and Shank Dimensions

Nominal Fastener Diameter [D]	Fastener Type	D _{head}	D _{shd}	D _a	Drive Bit
in. [mm]		in. [mm]			
5/16 [8]	Kombi	0.472 [12]	0.315 [8]	0.354 [9]	RW 40 or 19/32" Hex Socket
3/8 [10]	Kombi	0.591 [15]	0.394 [10]	0.433 [11]	
1/2 [12]	Kombi	0.669 [17]	0.472 [12]	0.511 [13]	

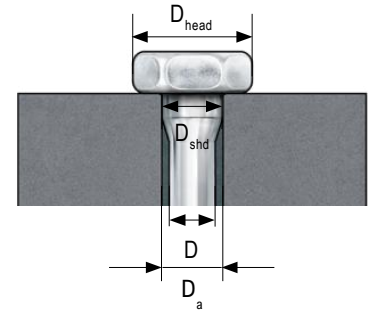
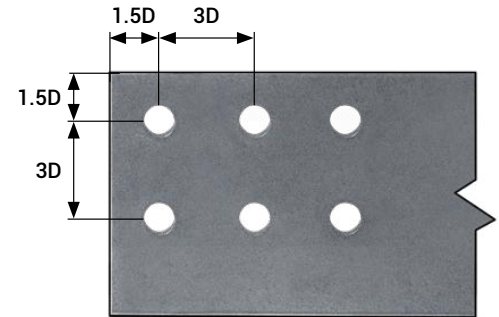

Table C.3 - Steel Plate Geometry Requirements for Fully Threaded Fasteners

Geometry Requirement	Minimum Dimension
	Any D
Distance between fasteners in a row	3D
Distance between rows of fasteners	3D
End distance	1.5D
Edge distance	1.5D



Note:

- These values are in accordance with ICC-ESR-3178 (2023) Section 4.2.2.

Minimum Steel Plate Thickness Below Fastener Head

For inclined screws in steel side members, their head should be completely countersunk within the milled hole as shown in the figure below. To completely countersink the screw head, the steel plate must be milled at an appropriate angle and to the correct head dimensions. To ensure sufficient stability of an inclined screw with a countersunk head, maintaining a minimum thickness, *s*, below the head is recommended. For fasteners utilized with wedge washers, refer to the minimum and maximum plate sizes in the Accessories chapter.

- $\alpha > 45^\circ$, then, $s \geq 1/8" [3 \text{ mm }]$
- $30^\circ \leq \alpha \leq 45^\circ$, then, $s \geq 5/64" [2 \text{ mm }]$

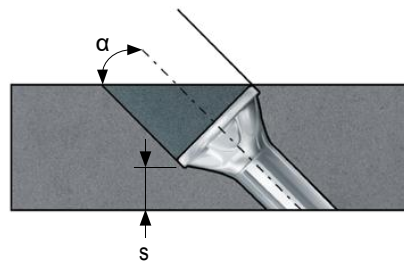

Appendix D: Service Conditions and Durable Design

When selecting fasteners and materials for timber construction, multiple factors must be carefully considered to ensure a durable connection, including not only corrosion resistance, but also susceptibility to hydrogen embrittlement (HE), and the impact of wood swelling and shrinkage. Durable design extends beyond the fasteners themselves, requiring a holistic approach that takes into account the properties of the timber. The wood must have sufficient resistance to maintain long-term durability, with dry service conditions generally being more favorable.

Wet service conditions, in particular, can significantly affect the overall resistance of the connection, necessitating the application of adjustment factors to ensure structural integrity. Additionally, moisture exposure can compromise the durability of the timber itself, underscoring the importance of selecting the appropriate treatment to protect against rotting.

Corrosion, a natural process that occurs when metallic materials interact with their environment, cannot be entirely prevented. However, careful planning, detailing, and the use of protective measures can mitigate its damaging effects. It is the responsibility of design professionals to consider all these parameters—environmental factors, service conditions, galvanic (bimetallic) corrosion, HE, and timber treatment—to ensure the long-term durability and safety of the structure. This appendix provides comprehensive guidance on addressing these challenges, with a particular focus on understanding service conditions and incorporating durable design recommendations.

Service Conditions and Other Factors Impacting Corrosion

Maintaining dry service conditions for timber connections as defined in NDS 2024 is not only crucial for corrosion resistance but also serves to prevent decay of the wood fibers. As wood fibers absorb more moisture, they lose strength, which is why reduction factors are imposed on the strength properties and connection resistance. Understanding these service conditions is essential for ensuring both the durability of the connection and the overall structural integrity.

Dry Service Conditions

Applications falling within the dry service condition category are generally confined to indoor environments but may extend to exterior settings where connections are sheltered and unexposed to the elements. It is essential to account for the possibility of prolonged moisture presence during construction, as this might necessitate a reclassification of the service conditions or pre-service conditions, requiring a modification of the adjustment factor C_m (NDS 2024 Section 11.3.3). Regular corrosion-resistant fasteners with a minimum 8 micron A3K surface coating are intended for use in dry service conditions. For structures exposed to the elements, careful consideration should be given to protection of members and connections when designed using dry service conditions.

Wet Service Conditions

This category applies to connections that do not meet dry service conditions and that do not fall within the Increased Corrosion Risk category (see Page 15). This typically applies to connections exposed to the elements such as outdoor construction projects, exterior structures permanently exposed to the elements, and sheltered structures that are still subject to precipitation or high humidity. This may also apply to connections in indoor applications such as indoor pools or greenhouses. The following summarizes circumstances in which wet service conditions may apply to a connection design:

- The moisture content (MC) of the wood exceeds 19% at the time when the connection is fabricated, i.e., the pre-service conditions. Refer to NDS 2024 Section 11.3.3 for adjustment factors for connections fabricated in green wood.
- The connection is exposed to direct wetting from elements such as rain, snow, splashing, dripping, or condensation, impeding quick and effective drying.
- The equilibrium MC (EMC) of wood exceeds 15% averaged over the year or 19% at any given time (per industry best practice). Designers can estimate EMC from the following graph.

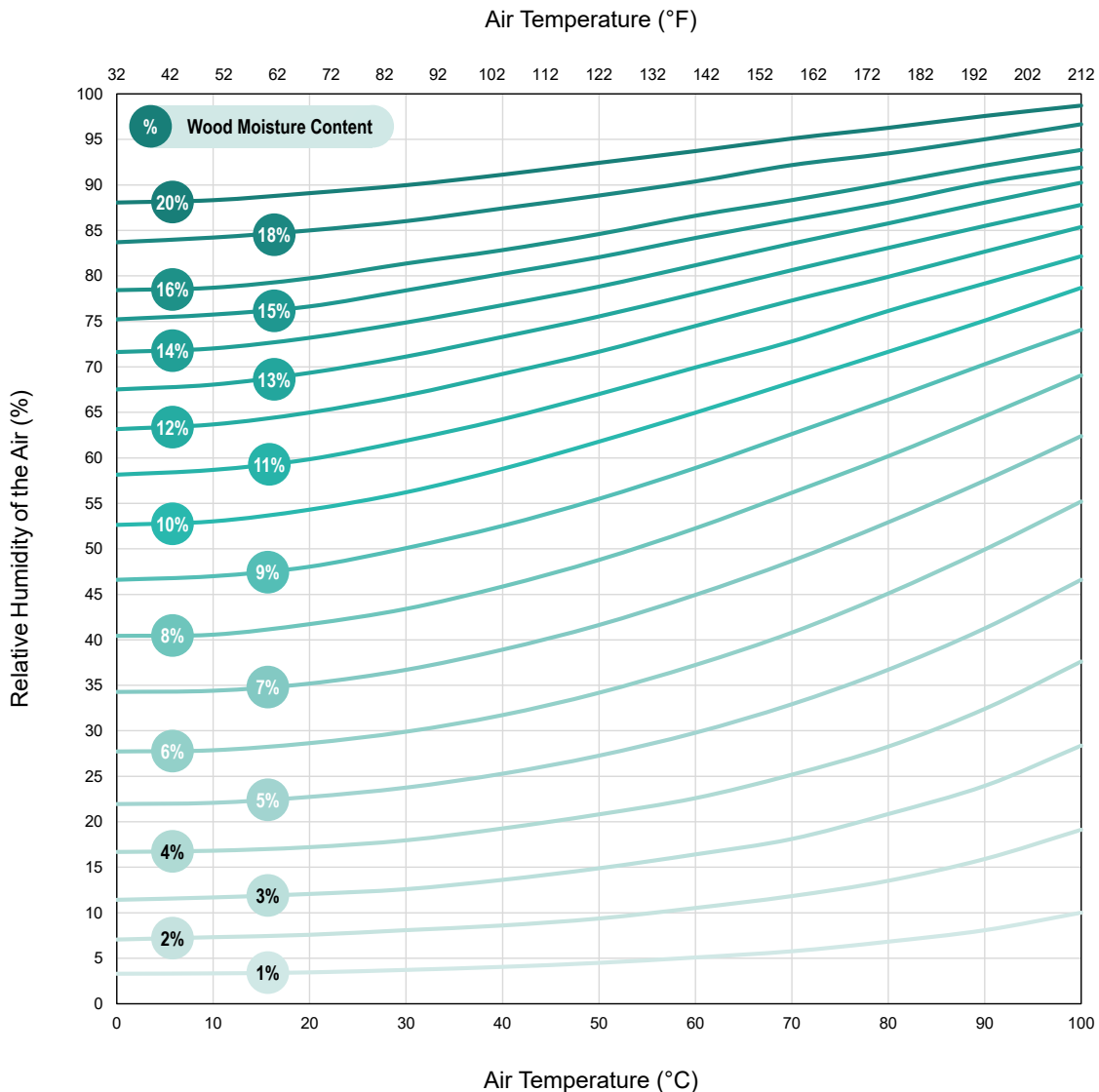

Wood EMC as Related to Environmental Conditions

Increased Corrosion Risk Categories

Waterfront Service Conditions

Connections exposed to highly corrosive environments such as ocean salt air and salt water require extreme corrosion-resistant fasteners. According to FEMA, this can apply to structures within 3,000 ft. of a salt-water body, but this may vary dependent on local regulations. Fasteners exposed to waterfront service conditions may require additional corrosion resistance as outlined in AC 257, such as that provided by A4 stainless steel.

Exposure to Aggressive Substances

This category encompasses connections exposed to industrial emissions, agricultural chemicals, specific soil types, de-icing salts, chlorine, acid rain, and various other corrosive substances. It is recommended that a corrosion risk analysis be performed by a qualified professional and that the service life of the connection be evaluated. Fasteners exposed to aggressive substances may require additional corrosion resistance as outlined in AC 257, such as that provided by A4 stainless steel.

Chemically Treated Lumber

Wood fiber treatment may increase the risk of corrosion, especially in the presence of moisture. Lumber treated with certain preservatives, such as copper azole (CA) and alkaline copper quat (ACQ), exhibits an elevated tendency to induce corrosion in metals within high-moisture environments. This heightened corrosive effect is ascribed to copper's highly galvanic nature, making one of the metals in the couple the anode and accelerating corrosion (see the Bimetallic Contact Corrosion section for more details). Compared to CA, ACQ is more corrosive. Its organic components attract moisture, intensifying fastener corrosion. Therefore, applications involving chemically treated lumber may require fasteners with a high level of corrosion resistance.

If there is uncertainty about the specifics of treatment chemicals or the environmental conditions, MTC Solutions recommends choosing stainless steel hardware of an appropriate grade. However, it must be noted that MTC Solutions has not evaluated all chemical formulations or treatment processes. While manufacturers may provide independent test results or additional product details, MTC Solutions does not endorse or provide opinions on such third-party information.

Other Fastener Degredation Mechanisms

Bimetallic Contact Corrosion

Galvanic (bimetallic) corrosion is an electrochemical process where dissimilar metals (e.g., carbon steel and aluminum) are immersed in a conductive solution (e.g., water), leading to corrosion of the more anodic material. This electrochemical process happens without the need for an external electrical charge. Effective strategies for mitigating galvanic corrosion include preventing the accumulation of conductive solutions, such as water, and eliminating contact between dissimilar metals. If this is not possible, physical separation of the two metals using a nonconductive material is a viable alternative. In situations where dissimilar metals cannot be avoided, it is considered best practice to opt for fasteners with a lower galvanic corrosion potential such as stainless steel.

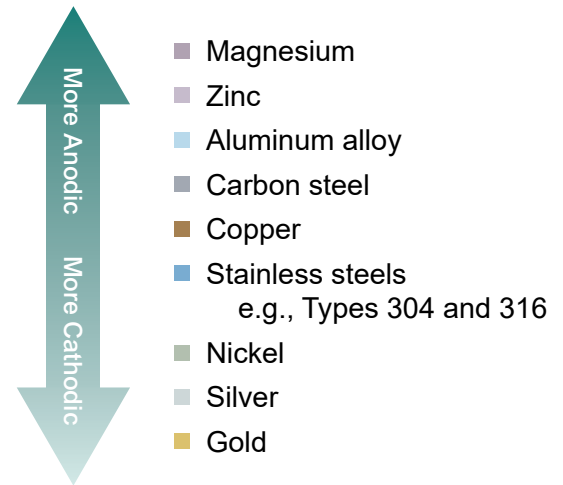

Galvanic Series of Metals and Alloys

Hydrogen Embrittlement (HE)

HE is a delayed embrittlement mechanism that can lead to the degradation and eventual failure of fasteners. It is crucial to differentiate HE from general corrosion resistance, as even fasteners considered ductile may become embrittled if made from susceptible materials or used in inappropriate applications. There are two types of HE that must be considered and mitigated when working with self-tapping screws: internal and environmental.

Internal Hydrogen Embrittlement (IHE)

Fasteners supplied by MTC Solutions meet ISO 2702 standards during the manufacturing process and have a core hardness below 390 HV in order to mitigate IHE. In addition, MTC Solutions utilizes post-manufacturing inspection techniques to verify our fasteners have a core hardness of below 390 HV in accordance with industry best practices, as well as tension testing in accordance with ISO 4042 and ISO 15330, which further mitigates the risk of a brittle HE failure.

Environmental Hydrogen Embrittlement (EHE)

EHE occurs when there is re-introduction of hydrogen from the environment. There are two main sources of hydrogen in the environment: corrosion by water and/or acid. It is the responsibility of the designer to mitigate EHE potential.

Fasteners typically encounter water during on-site storage or due to wet service conditions, and typically encounter acid through cleaning processes. To mitigate EHE from these causes, MTC Solutions recommends the following:

- Fasteners shall be stored in a dry environment.
- Carbon steel fasteners with a maximum core hardness above 36 HRC (360 HV), such as MTC carbon steel fasteners, shall not be used in wet service conditions in accordance with industry best practices.
- Fasteners shall not come into contact with acid-based cleaning solutions.

Design and Detailing Considerations for Durability

Suggested Fastener Specification Language

1. All fasteners for timber applications shall conform to NDS 2024.
2. All case-hardened, carbon steel, self-tapping wood screws must have a core hardness ≤ 390 HV, in accordance with ISO 2702. For case-hardened, carbon steel fasteners used in wet service conditions, the core hardness must be ≤ 360 HV. Wet service applications will require additional measures to prevent corrosion.
3. All case-hardened, carbon steel, self-tapping wood screws with a core hardness between 360 HV and 390 HV must have an additional quality assurance plan in accordance with ASTM F606 Clause 7 or ISO 15330.
4. Electroplated fasteners must be manufactured per ISO 4042 or ASTM F1941 with a zinc coating thickness of at least 8 microns.
5. Follow the manufacturer's installation instructions, including recommended tools, drive-in torque limits, and predrilling requirements.
6. For dry service conditions, the timber moisture content (MC) should average 15% or lower throughout the year and must not exceed 19% at any time.
7. Fasteners must be stored in a dry environment prior to installation to prevent exposure to moisture and other corrosive elements.
8. The shop drawings and Bill of Materials for all fasteners must be reviewed and approved by the Structural EOR prior to installation.

Sheltered Connections

Timber connections that are sheltered but may be exposed to wind-driven rain or high humidity require careful detailing to prevent moisture-induced degradation. Exposed end grain should be avoided to reduce excess moisture absorption due to capillary effects. Considerations should include protective overhangs, end caps, or other flashings to minimize exposure and the use of corrosion-resistant fasteners suitable for the expected moisture levels.

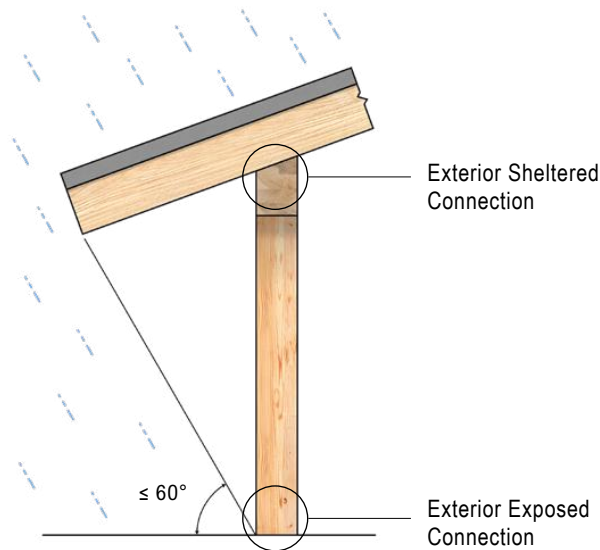

Sheltered and Exposed Connections

Moisture Management During Construction

During the construction process, shield members with covers or use strategic positioning in areas protected from direct rainfall.

Avoid water pooling by detailing elements and connections for adequate drainage to mitigate corrosion and degradation of the wood fiber. Examples of proper detailing can include sloping surfaces away from timber elements or providing drainage channels that prevent water from collecting. A Building Envelope consultant can provide further guidance. Uneven drying, such as rapid drying of a portion of an element from direct sun exposure, can create nonuniform stress distributions in timber elements, potentially leading to excessive checking. Ensure that timber elements are allowed to dry uniformly with shading techniques or by rotating timber elements during the drying process.

During construction, mass timber elements may experience temporary surface wetting, potentially causing the timber surface moisture content (MC) to exceed 19%. In such cases, A3K electroplated carbon steel fasteners are acceptable for use, provided that the following three conditions are met. First, the surface wetting shall not exceed the moisture limits defined for dry service conditions for more than a few weeks per year. Second, the annual average MC during construction shall remain within the range of 10–16%. Third, the design must incorporate appropriate detailing to accommodate dimensional changes in the wood due to wetting and/or drying. If any of these conditions cannot be met, fasteners with enhanced corrosion resistance are recommended, and detailing must be adjusted accordingly.

Moisture-Related Movement

In applications where variations in wood MC are expected, special detailing is required to accommodate the natural shrinkage and swelling of the timber. As sawn lumber primarily undergoes dimensional change in the cross-section (aligning with the tangential and radial directions relative to grain), designers should account for the anticipated movement. Improper connection detailing that does not consider moisture-induced dimensional changes can give rise to the development of restraint forces, resulting in wood splitting or reduced connection performance. To assist with detailing for moisture-related movement, designers can refer to Chapter 13 of the USDA Wood Handbook which states the expected change in dimension, ΔD , within the MC range of 6–14% can be estimated using a dimensional change coefficient derived from the dimension at 10% MC:

$$\Delta D = D_I [C_T (M_F - M_I)] \quad (\text{eq. 11})$$

$$C_T = \frac{1}{\left(FSP \cdot \frac{100}{S_T} \right) - FSP + M_I} \quad (\text{eq. 12})$$

D_I	dimension in units of length at start of change
C_T	dimensional change coefficient for the tangential direction
M_F	moisture content (%) at end of change
M_I	moisture content (%) at start of change
FSP	fiber saturation point (assumed at 30% MC unless noted otherwise)
S_T	tangential shrinkage

Note:

- For calculations in the radial direction, C_R (dimensional change coefficient in the radial direction) and S_R (radial shrinkage) replace C_T and S_T , respectively.

Table D.1 - Dimensional Change Coefficients for Common Wood Species in Mass Timber Construction

Species	Dimensional Change Coefficient	
	C_R	C_T
Southern Pine (loblolly)	0.00165	0.00259
Douglas Fir (interior west)	0.00165	0.00263
Spruce-Pine-Fir (black spruce)	0.00141	0.00237

Note:

- Excerpted from Wood Handbook, Wood as Engineering Material (2021) Table 13-15.

Steel Side Plates

Connections with steel side plates can restrict the natural movement of wood, preventing it from expanding or contracting with changing ambient conditions. It is preferable to allow the wood to shrink or swell with minimal restraint to maintain its structural integrity. In some cases, connectors can be designed with slotted holes to accommodate moisture-related movement. Except for connections in CLT, it is recommended to limit the distance between the outermost fasteners perpendicular to the grain to no more than 5 in. This limitation helps control restraint forces within a connection, preventing wood splitting and maintaining connection performance.



Maximum Spacing Between Outermost Rows of Fasteners

Green Wood

On occasion, fasteners are installed into green wood (with over 30% MC), which undergoes significant drying in the early stages of a building's service life. When wood is below 19% MC, any water present will be bound in the wood cell walls. Above the fiber saturation point (FSP), typically around 30% MC (depending on wood species), all the additional water will be free water within the lumen. Between 20% and 30% MC there is a transition phase, where some free water starts to accumulate. As the MC increases, any water will be absorbed by the wood cell walls as "bound water," which causes the cell walls to thicken. Once the MC exceeds the FSP, additional "free water" will be stored in the cell lumen. The changes in cell wall thickness correspond with dimensional changes, which are primarily perpendicular to the grain. It is important to detail to accommodate the shrinkage that will occur as the wood dries out.

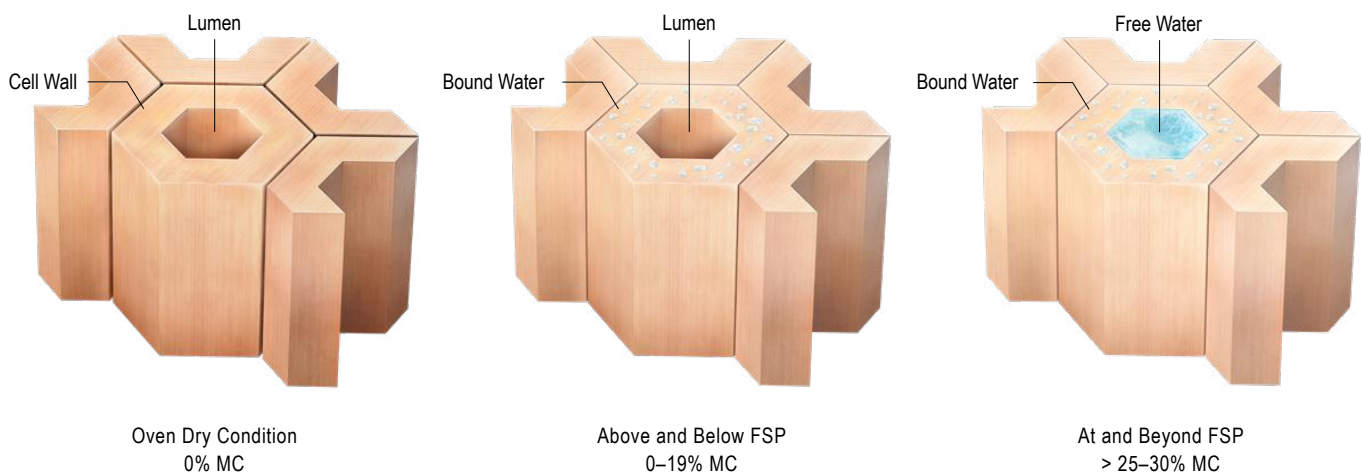

Water Movement in Wood Cells

End Grain Connections

Connections at the end grain demand careful consideration when subjected to differential drying—a common cause of checking—in heavy timber members. Most building codes include special provisions for screws in withdrawal installed at a 0° angle in the end grain, motivated by the potential development of checks and splits along the grain. In some cases, the fastener axis may run parallel to these voids, resulting in lower capacity, particularly when the fasteners are loaded in withdrawal. As an example, installing fasteners at a 30° angle to the grain enables the fasteners to pass through checks and splits.

The following recommendations for fasteners in withdrawal in end grain applications can help ensure desired connection performance:

- Install the screws at an angle relative to grain greater than approximately 30°
- Use a minimum of four screws in each connection
- Ensure a minimum thread penetration length of $20D$
- Apply the appropriate end grain factor, C_{eg} , when calculating the design capacity



Green Wood



Dry, Checked Wood



Dry, Checked Wood
with Inclined Screws

Appendix E: Installation Guidelines

A proper installation procedure is critical for a connection to perform as intended by the design engineer. Installing high-capacity fasteners into critical connections requires the utmost level of accuracy and craftsmanship. The following sections provide information on why it is important to create and follow an installation procedure, as well as additional tips and best practices. It is important to follow the instructions outlined in these sections to prevent reduced connection capacities, undesired connection performance, and fastener-related issues such as breakage, collision, and deviation.

General Installation Instructions

I Use the Correct Bit

MTC Solutions fasteners should only be driven using RW bits or appropriately sized Torx bits. This approach ensures good centering and positioning with optimal torque transmission.

Note:

- For information on bit selection refer to the tables on the Product Overview page for each fastener.

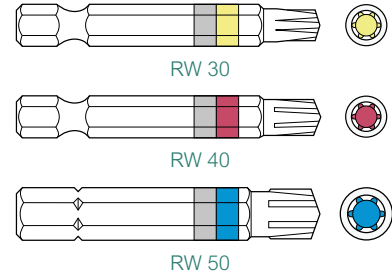

II Use the Correct Drill

Use low-RPM, high-torque drills equipped with a feather (variable speed) trigger to install MTC Solutions fasteners. Avoid excessive acceleration and deceleration during the drive-in process. Do not overtorque fasteners. Although impact guns are not expressly prohibited, their use is discouraged - particularly in steel-to-wood connections - due to an increased risk of overtorquing. If an impact drill is utilized, limit its use to short screws. Use the appropriate drill chuck size according to the fastener diameter:

E.1 - Recommended Drill Bits and Power Drill

Nominal Fastener Diameter [D]		HSS Drill Bit	Power Drill Voltage	
in.	[mm]	in.	[mm]	V
1/4	[6]	5/32	[3.9]	20
5/16	[8]	3/16	[4.8]	20
3/8	[10]	1/4	[6.4]	60
1/2	[12]	17/64	[6.7]	60*
9/16	[14]	5/16	[7.9]	60*

* A double handle drill is recommended.

Refer to product chapters for allowable insertion torque values.

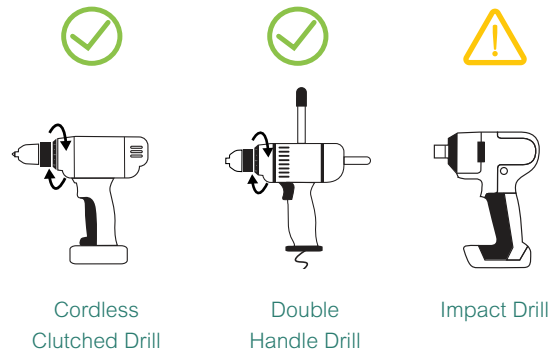

III Align Drill Bit Axis

The drill bit axis must be parallel to the fastener axis during installation to ensure proper torque transmission and to avoid stripping the housing of the bit.

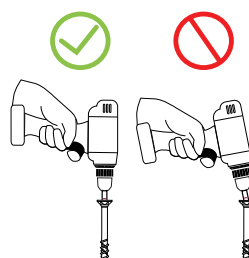

IV Decrease RPM

To avoid screw overtorquing, decrease the rotation speed about 1/2 in. away from the final seated position. This is especially important for steel-to-wood connections and when using an impact drill.

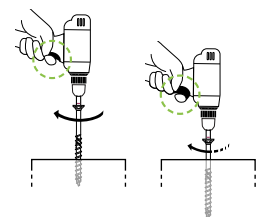

V Do Not Press on the Drill

Do not apply excessive pressure on the drill once the fastener is engaged, as even a slight amount of buckling will cause the fastener to deviate from its intended path. Only apply the required force or use the recommended holder case to eliminate cam-out effects.

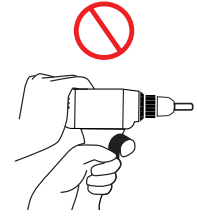

VI Prevent Fastener Deviation

Density variations in the wood, such as knots, may cause long and slender fasteners to deviate from the desired installation path. This can lead to reduced connection capacity and risk of screw collision. Predrilling or drilling pilot holes reduces the risk of fastener deviation.

VII Prevent Screw Collision

Fastener collision in the wood member can occur due to deviation from the installation path. The resulting sudden torque increase can lead to fastener breakage. Predrilling before installation reduces the risk of fastener deviation and helps avoid screw collision.

VIII Install in a One-Step Process

To avoid increased torque peaks caused by stopping and restarting the drive-in process, install the screw in one run until the head is lightly seated against the side member. If necessary, a torque wrench may be used to complete installation immediately after the fastener has been driven.

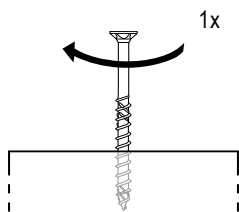

IX Installation Near Edges

In near-edge applications, the fastener may be slightly inclined inward ($< 5^\circ$) to prevent the screw from curving outward and protruding out of the wood. Alternatively, predrilling can be performed to ensure a proper penetration path and reduce splitting risks.

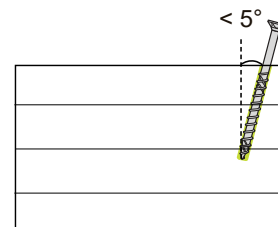

X Use Predrilling Jig

Perpendicular bearing of the screw head on a steel plate is required to allow for proper load transfer. An improper bearing can lead to unintended load interactions and breakage. Precise and accurate predrilling with accessories such as predrilling jigs avoids this risk by ensuring the proper alignment of the penetration path.

Predrilling and Pilot Holes

I Predrilling

A predrilled hole, defined as a hole with a depth equivalent to the length of the fastener, serves the purpose of reducing geometry requirements during installation. It is crucial to ensure that the diameter of the predrilled hole follows the recommended values in the table below. Utilizing predrilled holes can optimize the installation process and ensure optimal results in fastener placement in high-capacity connections.

Predrilling is recommended for installing slender fasteners into dense wood, such as SYP.

II Pilot Holes

A pilot hole, defined as a partial-length hole, facilitates fastener installation by guiding the fastener during initial insertion and reducing the insertion torque. The installer should use their discretion regarding the length of the pilot hole, ensuring that the diameter does not exceed the minor diameter of the fastener. When working with steel plate connections, especially at angles, utilizing a predrilling jig for locating an accurate hole is highly recommended.

E.2 - Recommended Diameters for Predrilled and Pilot Holes

Nominal Fastener Diameter [D]	Predrilled Hole Diameter	Pilot Hole Diameter	Steel Plate Hole Diameter
in. [mm]			
1/4 [6]	5/32 [4]	≤ 5/32 [≤ 4]	9/32 [7]
5/16 [8]	3/16 [5]	≤ 3/16 [≤ 5]	3/8 [9]
3/8 [10]	1/4 [6]	≤ 1/4 [≤ 6]	7/16 [11]
1/2 [12]	17/64 [7]	≤ 17/64 [≤ 7]	17/32 [13]
9/16 [14]	5/16 [8]	≤ 5/16 [≤ 8]	N/A

Notes:

- Full-length predrilling is intended to reduce connection geometry requirements according to ICC-ESR-3178 and 3179. The predrilling length should be equivalent to the fastener length.
- Pilot holes can reduce splitting risks, while ensuring a proper penetration path and faster thread engagement. A minimum pilot hole depth of 1 in. is recommended.
- Predrilled holes exceeding the diameters listed above reduce the screw capacity.
- These recommendations are only applicable to ASSY fasteners supplied by MTC Solutions.
- Connection design must meet all the relevant requirements outlined in the General Notes to the Designer section.

Fastener Installation in Steel Side Plates

This section highlights the recommended installation sequence and instructions for steel-to-wood connections using lateral or inclined screws.

1. Create a list and assemble all tools required according to the type and diameter of the fasteners being installed. Installers should ensure all tools are properly calibrated.
2. Place and secure the steel side plate at the correct position on the wood main member.
3. Secure the steel plate to its specified location on the wood member using smaller-diameter locator screws, as shown in Figure a, to prevent misalignment. Design professionals should specify holes to accommodate locator screws.
4. Use of pilot holes, while optional, is recommended to ensure precise installation of screws. If desired, drill a pilot hole in every screw location with an appropriate predrilling jig and a drill bit with a proper diameter to a depth of at least 1 in. [25 mm].
5. Clear off all sawdust inside and around the holes.
6. Start the fastener installation process from the innermost screw row to the outermost screw row, as shown in Figures b through d. In general, start with the innermost screws and move toward the outer edges, where residual stresses can be released.
7. Install the fasteners using the correct drill and bit. During the drive-in process, do not apply excessive pressure on the fasteners. Continue the installation process until the fastener head (lightly) contacts the steel plate. Stop here and remove the drill.
8. (Optional) If the use of a torque wrench is specified by the designer, individual fasteners should be torqued immediately after completion of the previous step. Switch to a torque wrench with a socket bit holder and use the correct bit to slowly drive each fastener to the specified torque. The adjusted torsional value for each fastener is listed in the specified resistance value tables.
9. Install the remaining screws consistently from one side of the connection to the other, each time stopping when the fastener head lightly contacts the steel plate.

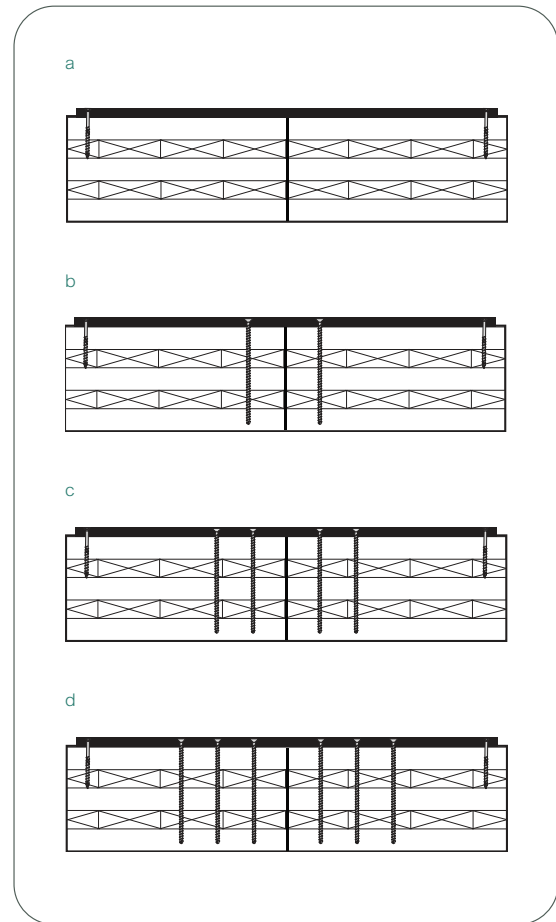

Notes to the Design Engineer

- a) Steel plate detailing should accommodate commonly available locator screws by incorporating suitable holes in the top left and bottom right, especially in end grain connections where the grain orientation can cause fastener deviation during steel plate installation.
- b) Extra holes (~10% of the total required) should be specified for large steel-to-wood tension connections to account for potential installation errors (e.g., accidental damage to screws).

MTC Solutions provides sustainable, high-quality mass timber connection solutions to a rapidly evolving and thriving industry. We drive innovation through certified research and development, while contributing to the education of young talent and experienced professionals in the technology used in sustainable design.





MYC
SOLUTIONS

info@mtcsolutions.com

1.866.899.4090

mtcsolutions.com

