



Beam Hangers Design Guide



Disclaimer

The information in this document is for general information purposes. While MTC Solutions aims to keep the information provided in this document complete, accurate and in line with state-of-the-art design methods, MTC Solutions does not make warranties of any kind.

Images and drawings provided are for reference only and cannot be applied to all conditions that may occur on site. Any reliance users' place on such information is therefore strictly at your own risk. Under no circumstances does MTC Solutions assume liability for any loss or damage including and without limitation, indirect or consequential loss or damage, or any loss or damage whatsoever arising from loss of profits arising out of, or in connection with the use of the system. Users are able to derive other loading cases which are beyond MTC Solutions' control. The inclusion of the system or the implied use of the document to other applications is beyond the scope of MTC Solutions' responsibility.

Table of Contents

GENERAL NOTES TO THE DESIGNER	10
BEAM HANGER: SELECTION TOOL	11
GIGANT BEAM HANGERS	12
GIGANT Hardware	13
GIGANT 120 x 40.....	15
GIGANT150 x 40.....	16
GIGANT 180 x 40.....	17
Installation and Tolerances	18
RICON S VS BEAM HANGERS	21
RICON S VS Hardware.....	22
RICON S VS 140 x 60.....	23
RICON S VS 200 x 60.....	24
RICON S VS 200 x 80.....	25
RICON S VS 290 x 80.....	26
RICON S VS XL 390 x 80	27
Installation and Tolerances	28
MEGANT BEAM HANGERS	33
MEGANT Hardware.....	34
MEGANT 310 x 60.....	36
MEGANT 430 x 60.....	37
MEGANT 550 x 60.....	38
MEGANT 310 x 100.....	39
MEGANT 430 x 100.....	40
MEGANT 550 x 100.....	41
MEGANT 310 x 150.....	42
MEGANT 430 x 150.....	43
MEGANT 550 x 150.....	44
MEGANT 730 x 150.....	45
Installation and Tolerances.....	46
APPENDIX	53
Appendix A: Fire Design	54
Appendix B: Uplift Resistance Design.....	56
Appendix C: RICON S VS Reinforcement.....	57
Appendix D: Skewed & Sloped Configurations	62
Appendix E: Detailing Section	64

Mass Timber Hardware Specialist



At MTC Solutions, our core focus is to supply structural hardware for modern mass timber applications in commercial, industrial, and residential projects. We are proud to partner with leading industry experts, providing solutions and tools to design code-compliant buildings that are pushing the boundaries of the North American construction industry.

Our in-house team of mass timber specialists support professionals in designing connections that are tailored to the specific needs of each project, resulting in truly innovative and cost-efficient solutions. We are recognized as experts, moving the industry forward with tested and proven solutions.



Expertise

We provide the knowledge and tools to help our customers build cutting-edge and code-compliant mass timber projects while pushing the boundaries of the North American construction industry.



Commitment

We are dedicated to making your project a success, from design and installation support to delivering high quality products with speed and accuracy.



North American Tailored Products

We partner with leading research facilities across North America to ensure our products are tested and customized to fit the unique needs of the market, from seismic considerations to solutions for large post and beam structures in various climates.

Find Your Connection Solution

MTC Solutions provide the right tools to design code-compliant buildings, educating the mass timber industry on connection solutions.



Structural Screw Catalog



Structural Screw Connection Design Guide



Structural Fasteners



Accessories



Beam Hangers Design Guide



Beam Hangers



Connectors Design Guide



Connectors



Rigging Design Guide



Rigging Devices



Fall Arrest Anchor Design Guide



Fall Arrest



**WHO
ARE WE?**

YOUR MASS TIMBER HARDWARE SUPPLIER

Rely on our distribution team to deliver your North American projects with speed and accuracy.

LEADING WITH INNOVATION & RESEARCH

We are leading the mass timber industry with cutting edge connection solutions and partnering with renowned research facilities.

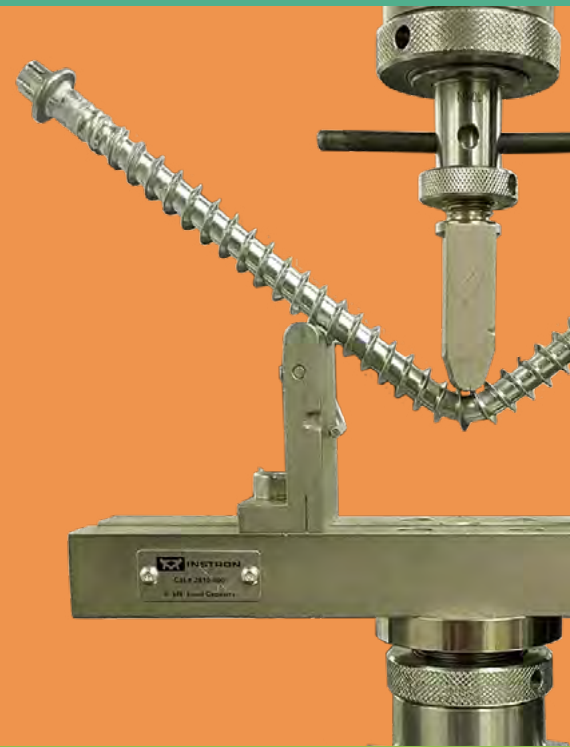

WE MAKE YOU THE EXPERT

Learn about the right solutions for your projects and Mass Timber connections with our technical resources & support team!

CONNECTIONS DESIGN SUPPORT

Reach out to the technical team for design support, from early design stages to ongoing iterative changes. We help find the most efficient connection solutions.



MANUFACTURERS' HELP DESK

Use our comprehensive & practical resources to find the most cost-effective solutions for your structural elements.



TESTED & PROVEN SOLUTIONS

Count on MTC Solutions' 10+ years of expertise, providing tested & proven ICC approved solutions, support, and resources.





Kingsway Royal Alex LRT Stations

Edmonton, Alberta

How to Use This Guide

Icon Explanation

This design guide features icons to assist the designer in selecting a suitable beam hanger system. The icons serve as a visual aid and highlight key features and attributes of each beam hanger system, allowing designers to quickly compare options and make informed decisions.

Compatible Materials

Icons that highlight structural materials that are compatible with the application of the beam hanger system.



Beam hanger system installable in wood

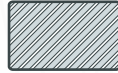

Beam hanger system installable in steel



Beam hanger system installable in concrete

Installation Possibilities

Icons that highlight assembly options for the beam hanger system. The systems can be installed from different directions relative to the main member. Each installation possibility shown is conceptual and does not take into consideration project specific constraints.

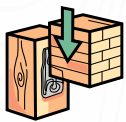

Drop-in installation from top

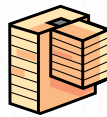

Connector fully concealable & housed into the wood member



Connector pre-installable into the members in a shop environment before delivery on site.

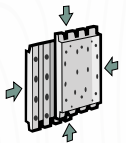

Connector installable from all directions (top, bottom, and sides)

Testing & Certification

Icons that highlight code approvals awarded to the beam hanger system and testing that the beam hanger system has undergone. Our pre-engineered beam hanger systems are extensively tested in different configurations, under various conditions.



Fire Resistance Rating achievable up to 3 hours of exposure as per TR-10

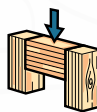

Allowable loads for the connector are derived in accordance with testing similar to ASTM D 7147

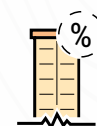

Inter-story drift tests performed

ISO 50001

Energy Management System

Facility producing the fasteners used to install the beam hanger system is certified to ISO 50001 standard



Evaluation Service Report (ESR) awarded to the beam hanger system by the International Codes Council (ICC)



The beam hanger system has been awarded a European Technical Approval (ETA)

General Notes to the Designer

1. Allowable loads for GIGANT and MEGANT connectors are derived in accordance with ASTM D 7147-11 and allowable loads for RICON S VS connectors are based on ICC-ESR 4300-2023. Values provided in the design tables are per Allowable Stress Design (ASD) and need to be adjusted in accordance with all applicable parameters listed in the NDS-2018.
2. Allowable loads provided are the maximum resistance permitted for each connector.
3. Minimum beam sizes suggested in this guide do not consider the shear capacity of the wood members. Allowable loads may exceed the resistance of the engineered wood product. The Design Engineer is responsible for continuous load path in all members.
4. Allowable loads provided are only valid for the listed associated GIGANT CSK screws for GIGANT connectors, and the listed associated ASSY screws for RICON S VS and MEGANT connectors.
5. Connectors in combination with carbon steel fasteners are to be used in dry service conditions only, i.e. $C_M = 1.0$.
6. Tabulated allowable loads include the load duration factor C_D and cannot be further adjusted for shorter load durations.
7. Tabulated allowable loads apply to connections that are exposed to sustained temperatures below 100°F. When connectors are installed in wood members that will experience sustained exposure to temperatures exceeding 100°F, the allowable loads must be adjusted by the temperature factor C_t , as described in the NDS-2018.
8. Connectors are to be centered with the resultant vertical force, with the plates installed symmetrically about the vertical axis. Horizontal eccentricities shall be avoided.
9. Connectors, if subjected to rotational forces, must be designed accordingly and appropriate additional measures must be defined by the Design Engineer.
10. Appropriate lateral supports should be provided for supported members (secondary member) to prevent torsional twisting.
11. If splitting of a wood member or fastener damage is observed prior to or during installation of the fasteners, the installation process must be stopped, and a design professional must be contacted immediately with the appropriate measures taken to rectify the issue.
12. Pilot holes may be used to facilitate the installation of the fasteners to provide greater precision. Pilot hole diameters shall not exceed the minor diameter (D_m) of the fastener.
13. Pre-drilling must be employed when installing connectors into PSL to avoid the risk of splitting.
14. Installation must respect all minimum beam size requirements including fastener geometry requirements and fire resistance rating requirements.
15. Reinforcement must be provided to beams where the minimum connection geometry requirements are not met.
16. For specific gravities (G) assigned to different timber species, refer to table 12.3.3A of NDS-2018.
17. The sample beam depths listed in this design guide are for reference purposes only. Note that tolerances for finished glulam dimensions provided within the ANSI 117 manufacturing standard may not provide the adequate squareness and depth required to ensure seamless field installation. A 1/4" (6mm) undersize in depth and 1/8" (3 mm) in width may be required. Verify all finished glulam dimensions with the timber provider.

Beam Hanger: Selection Tool

The following pre-selection table helps the designer in choosing the correct Beam Hanger System. The table lists the allowable loads for each system based on the minimum beam width and minimum beam depth.

More details on a specific Beam Hanger System can be found in the pages referenced in the table. Additional requirements such as geometry and special connections must also be taken into consideration, where applicable.

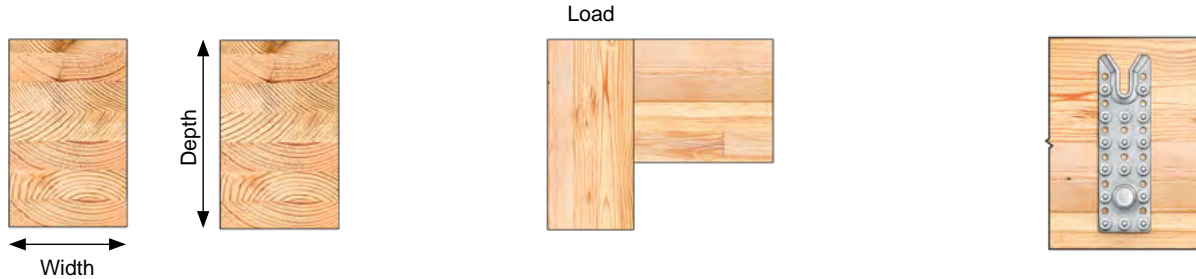

Minimum Beam Width		Minimum Beam Depth		Allowable Load		Connector	
in.	[mm]	in.	[mm]	kip		Model	Page
2-3/8"	60	11-1/8"	282	1.2	<div style="width: 10%;"></div>	Gigant 120x40	15
		11-1/4"	285	1.9	<div style="width: 15%;"></div>	Gigant 150x40	16
		11-5/16"	287	2.5	<div style="width: 20%;"></div>	Gigant 180x40	17
4"	100	11-5/16"	287	3.8	<div style="width: 25%;"></div>	Ricon S VS 140x60	23
		11-1/2"	292	4.8	<div style="width: 30%;"></div>	Ricon S VS 200x60	24
		15-3/4"	400	8.2	<div style="width: 50%;"></div>	Megant 310x60	36
		20-1/2"	520	12.8	<div style="width: 70%;"></div>	Megant 430x60	37
		25-1/4"	640	12.8	<div style="width: 70%;"></div>	Megant 550x60	38
4-3/4"	120	13-1/8"	335	6.9	<div style="width: 40%;"></div>	Ricon S VS 200x80	25
		16-3/16"	410	8.9	<div style="width: 55%;"></div>	Ricon S VS 290x80	26
		18-1/2"	470	15.0	<div style="width: 80%;"></div>	Ricon S VS XL 390x80	27
5-5/8"	140	15-3/4"	400	10.5	<div style="width: 50%;"></div>	Megant 310x100	39
		20-7/8"	530	17.5	<div style="width: 70%;"></div>	Megant 430x100	40
		25-5/8"	650	19.5	<div style="width: 75%;"></div>	Megant 550x100	41
7-1/2"	190	15-3/4"	400	13.6	<div style="width: 50%;"></div>	Megant 310x150	42
		20-1/2"	520	22.7	<div style="width: 75%;"></div>	Megant 430x150	43
		25-1/4"	640	31.7	<div style="width: 90%;"></div>	Megant 550x150	44
		33-1/8"	840	32.6	<div style="width: 95%;"></div>	Megant 730x150	45

Notes:

- Allowable loads listed here are only valid for Allowable Stress Design in the USA. This table is a pre-selection tool, please refer to each respective connector section and the NDS-2018 for design guidelines.
- Allowable loads listed here are only valid for use in $G \geq 0.50$ in standard term loading ($C_D = 1.0$), please refer to each respective connector section for additional values.
- Represents single connector allowable load.
 - Represents double connectors allowable load. Minimum beam width for double connector is larger than listed value, refer to respective connector section for minimum beam size.



Carbon 12

Portland, Oregon

GIGANT

Pre-Engineered Post to Beam Connector

The GIGANT are pre-engineered post to beam connectors. Manufactured from mild steel, they consist of two identical parts and are suitable for use in timber framing, log home building, mass, and heavy timber construction. Simple to install with structural screws perpendicular to their plate, they can be installed fully concealed or visible.



Pre-Installable

Pre-installable in controlled shop environment for a faster on-site installation



Drop-in Installation

A fast, streamlined & repeatable installation process that significantly enhances efficiency



Fully Concealable

Easy to conceal connections that enhance architectural wood features



Light Frame

Best used in timber framing & log home building

CERTIFICATIONS

ISO 50001

Energy
Management
System



ETA-10/0189 2019

GIGANT Hardware

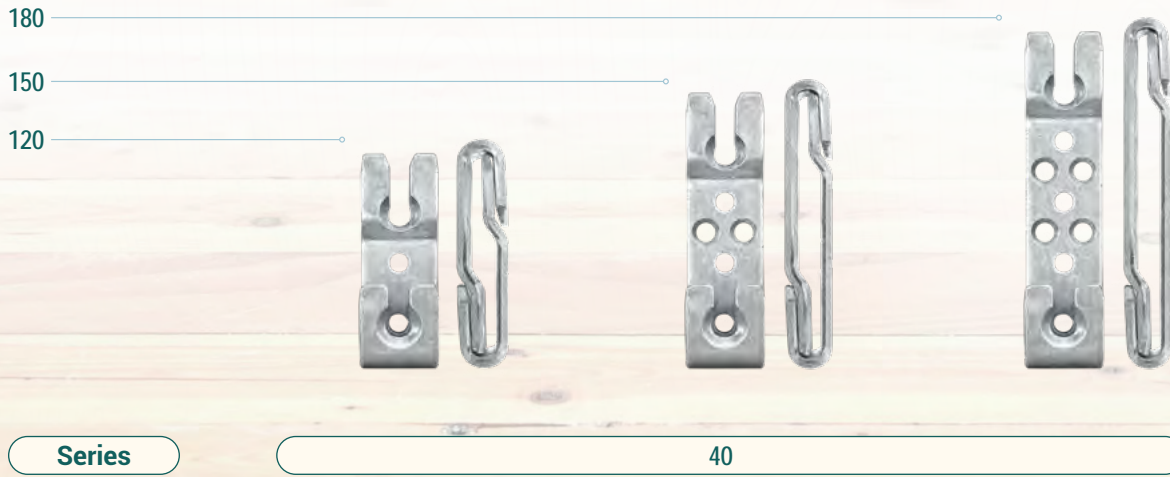

Note:

1. Product kit includes two identical connector plates.

Fastener - GIGANT CSK

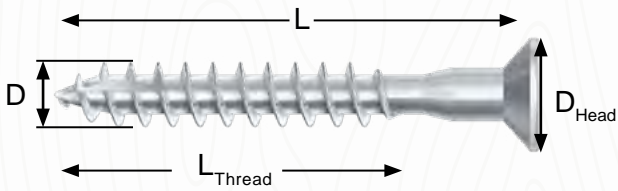

Item #	Type	D		L		L _{Thread}		D _{Head}		Bit
		in.	[mm]	in.	[mm]	in.	[mm]	in.	[mm]	
170110080000100	Gigant CSK Screws	3/8"	[10]	3-1/8"	[80]	2-1/4"	[54]	0.71	[18]	T40
170110120000100				4-3/4"	[120]	3-3/8"	[84]	0.71	[18]	

GIGANT 120 x 40

Connector Parameters and Dimensions

Compatible Materials



Installation Possibilities

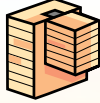

Testing & Certification



ETA-10/0189 2019

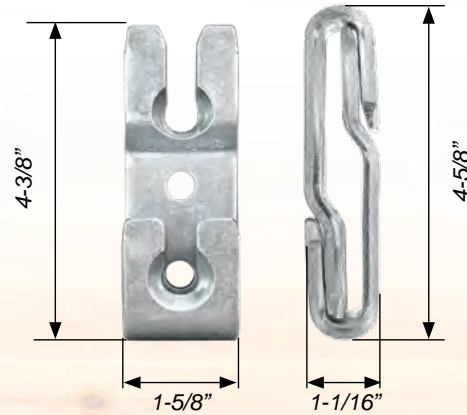

Table 1.1 Allowable Loads for GIGANT 120 x 40

Item	Min. Beam Section	Specific Gravity [G]	Fasteners				Allowable Down Load [lb]
			Primary Member		Secondary Member		
			Type	Qty.	Type	Qty.	
GIGANT 120x40	2-3/8" x 11-1/8"	0.42 [SPF]	GIGANT CSK 3/8" x 3-1/8"	3	GIGANT CSK 3/8" x 4-3/4"	3	1,090
		≥ 0.50					1,230

Notes:

1. Connection design must meet all relevant requirements of the General Notes to the Designer section.
2. Screw installation must follow the patterns presented in the Installation and Tolerances section.

Table 1.2 Minimum and Maximum Distances (a_{main} , a_{sec})

Beam Depth	a_{max}
11-1/8"	1-7/8"
12"	2-5/32"
13-1/2"	2-19/32"
15"	3-1/32"
16-1/2"	3-1/2"
18"	3-15/16"
19-1/2"	4-13/32"
21"	4-27/32"

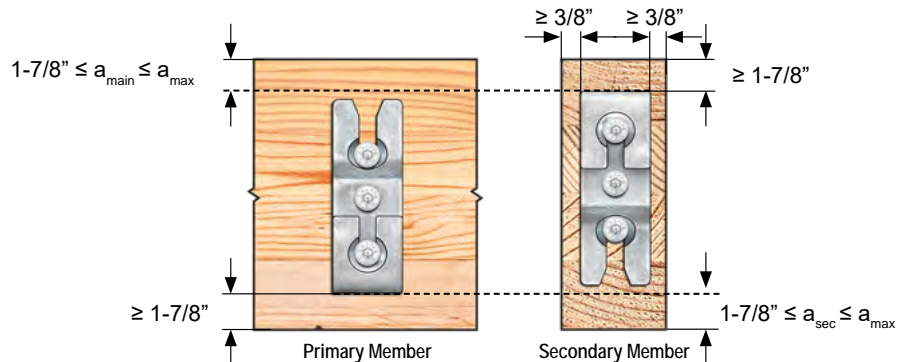

1. Maximum distances do not apply to primary post/column members (a_{main}), where the wood grain direction is parallel to the line of the force.
2. The Design Engineer may interpolate or extrapolate maximum values for a_{main} and a_{sec} for beam sizes not listed in the table.

GIGANT 150 x 40

Connector Parameters and Dimensions

Compatible Materials



Installation Possibilities

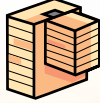

Testing & Certification



ETA-10/0189 2019

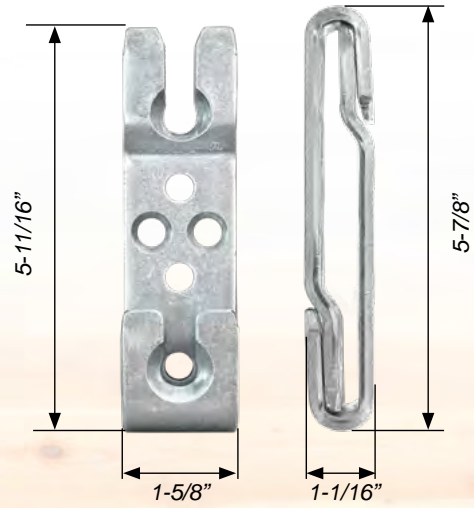

Table 1.3 Allowable Loads for GIGANT 150 x 40

Item	Min. Beam Section	Specific Gravity [G]	Fasteners				Allowable Down Load [lb]
			Primary Member		Secondary Member		
			Type	Qty.	Type	Qty.	
GIGANT 150x40	2-3/8" x 11-1/4"	0.42 [SPF]	GIGANT CSK 3/8" x 3-1/8"	4	GIGANT CSK 3/8" x 4-3/4"	4	1,640
		≥ 0.50					1,910

Notes:

1. Connection design must meet all relevant requirements of the General Notes to the Designer section.
2. Screw installation must follow the patterns presented in the Installation and Tolerances section.

Table 1.4 Minimum and Maximum Distances (a_{main} , a_{sec})

Beam Depth	a_{max}
11-1/4"	1-7/8"
12"	2-5/32"
13-1/2"	2-19/32"
15"	3-1/32"
16-1/2"	3-1/2"
18"	3-15/16"
19-1/2"	4-13/32"
21"	4-27/32"

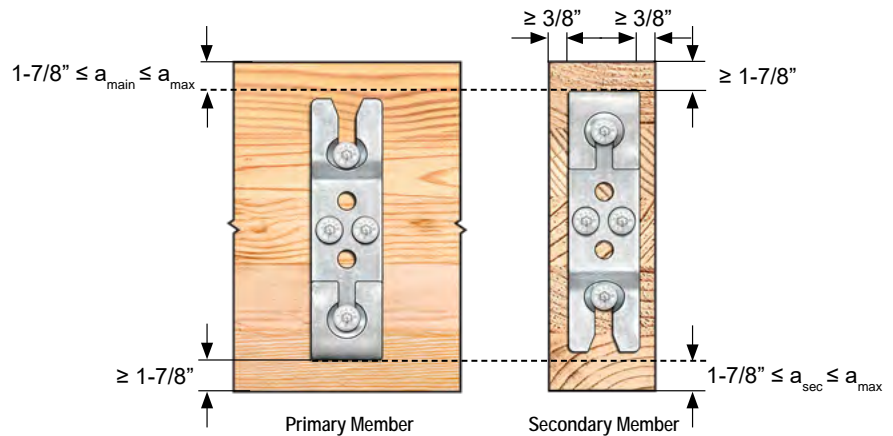

1. Maximum distances do not apply to primary post/column members (a_{main}), where the wood grain direction is parallel to the line of the force.
2. The Design Engineer may interpolate or extrapolate maximum values for a_{main} and a_{sec} for beam sizes not listed in the table.

GIGANT 180 x 40

Connector Parameters and Dimensions

Compatible Materials



Installation Possibilities

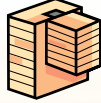

Testing & Certification



ETA-10/0189 2019

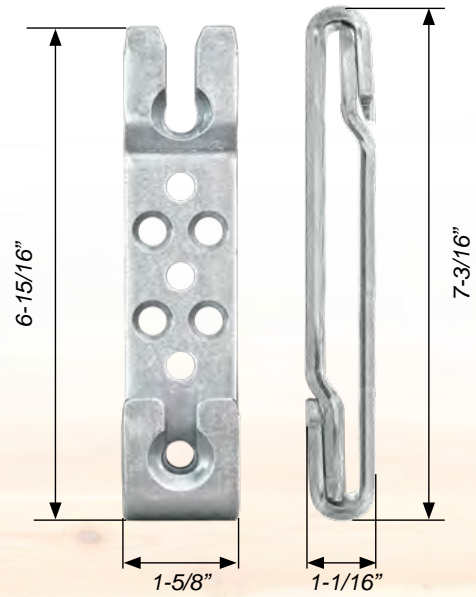

Table 1.5 Allowable Loads for GIGANT 180 x 40

Item	Min. Beam Section	Specific Gravity [G]	Fasteners				Allowable Down Loads [lb]
			Primary Member		Secondary Member		
			Type	Qty.	Type	Qty.	
GIGANT 180x40	2-3/8" x 11-5/16"	0.42 [SPF]	GIGANT CSK 3/8" x 3-1/8"	6	GIGANT CSK 3/8" x 4-3/4"	6	2,180
		≥ 0.50					2,460

Notes:

1. Connection design must meet all relevant requirements of the General Notes to the Designer section.
2. Screw installation must follow the patterns presented in the Installation and Tolerances section.

Table 1.6 Minimum and Maximum Distances (a_{main} , a_{sec})

Beam Depth	a_{max}
11-5/16"	1-7/8"
12"	2-5/32"
13-1/2"	2-19/32"
15"	3-1/32"
16-1/2"	3-1/2"
18"	3-15/16"
19-1/2"	4-13/32"
21"	4-27/32"

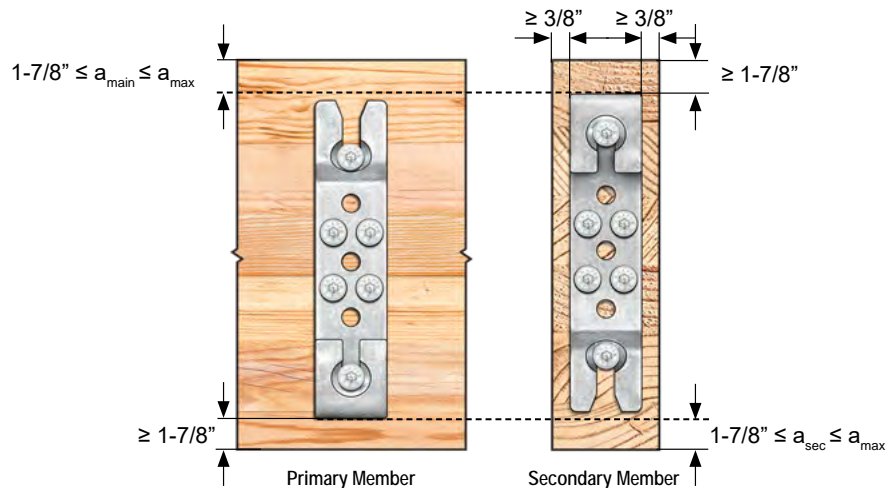

1. Maximum distances do not apply to primary post/column members (a_{main}), where the wood grain direction is parallel to the line of the force.
2. The Design Engineer may interpolate or extrapolate maximum values for a_{main} and a_{sec} for beam sizes not listed in the table.

Installation and Tolerances - Requirements

Routing in Primary Member Only

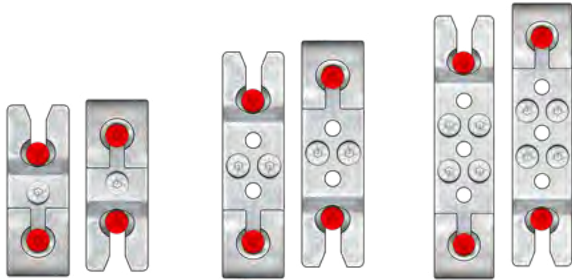

GIGANT
120 x 40

GIGANT
150x40

GIGANT
180x40

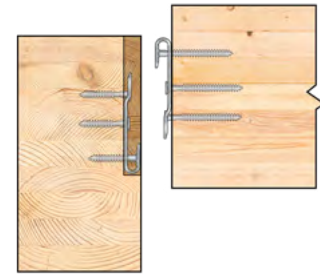

GIGANT Concealed in
the Primary Member

Notes:

1. The red markings indicate the positioning screws which should be aligned with the pre-drilled positioning holes on the wood members which are also indicated in red in the following figures.
2. All concealed installations are suggested to be field verified.

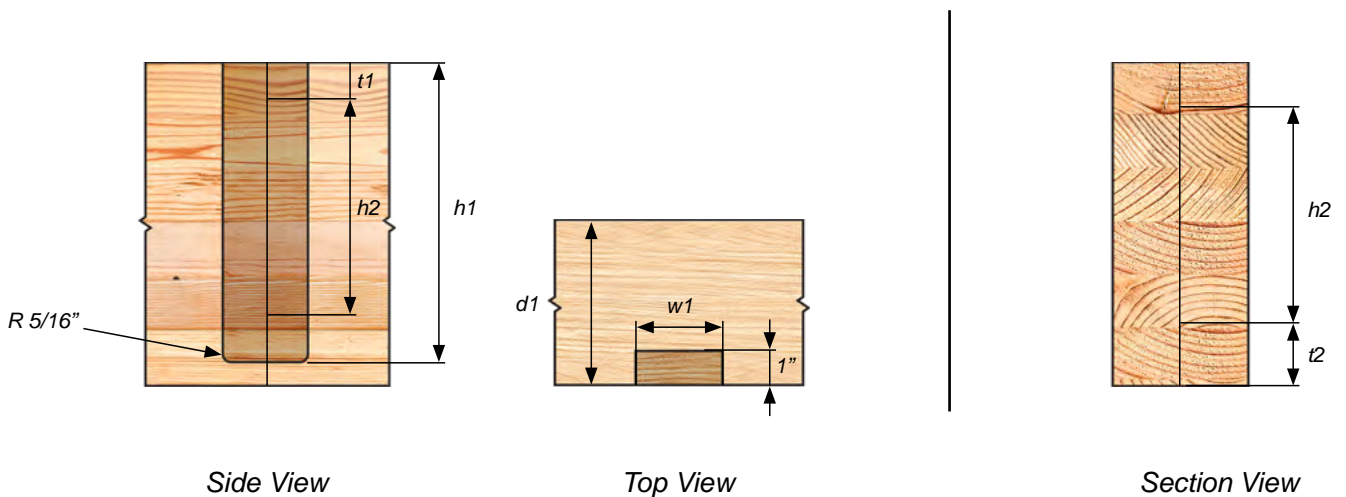

Side View

Top View

Section View

Primary Member

Secondary Member

Table 1.7 - Routing in Primary Member - Requirements

Connector	h1	h2	t1	t2	min. d1	min. w1
	in.					
GIGANT 120 x 40	$a_{main} + 4.638$	2.146	$a_{main} + 1.457$	$a_{sec} + 1.457$	4.567	1.685
GIGANT 150 x 40	$a_{main} + 5.937$	3.524	$a_{main} + 1.496$	$a_{sec} + 1.496$	4.567	1.685
GIGANT 180 x 40	$a_{main} + 7.197$	4.783	$a_{main} + 1.516$	$a_{sec} + 1.516$	4.567	1.685

Notes:

1. a_{main} refers to the top edge distance in the Primary Member where reinforcement is not required.
2. a_{sec} refers to the bottom edge distance in the Secondary Member where reinforcement is not required.
3. Tabulated values for h1 and w1 have been oversized by 1/32".
4. Tabulated d1 values include an additional 3/8" between tip of the screw and beam edge to avoid screw blow out.
5. Refer to the Geometry Requirement tables for each respective Beam Hanger System.

Routing in Secondary Member Only

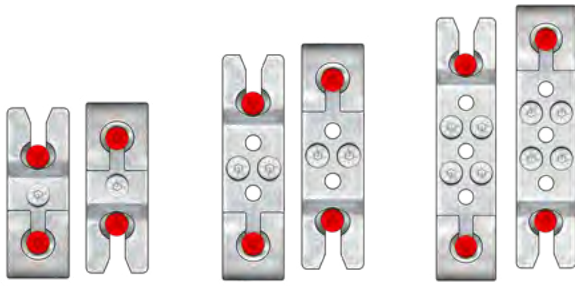

GIGANT
120 x 40

GIGANT
150x40

GIGANT
180x40

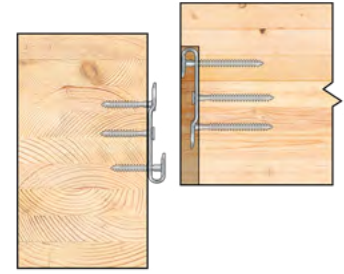

GIGANT Concealed in
the Secondary Member

Notes:

1. The red markings indicate the positioning screws which should be aligned with the pre-drilled positioning holes on the wood members which are also indicated in red in the following figures.
2. All concealed installations are suggested to be field verified.

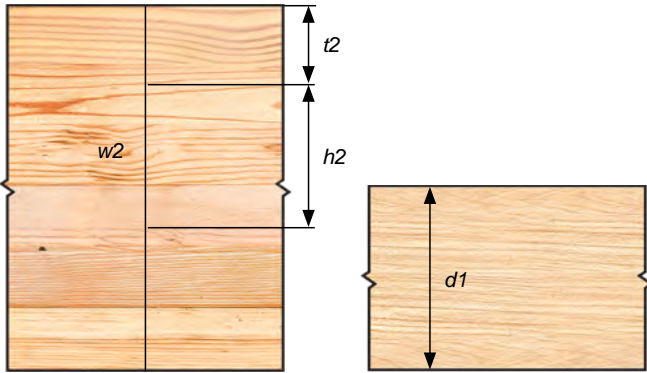

Side View

Top View

Primary Member

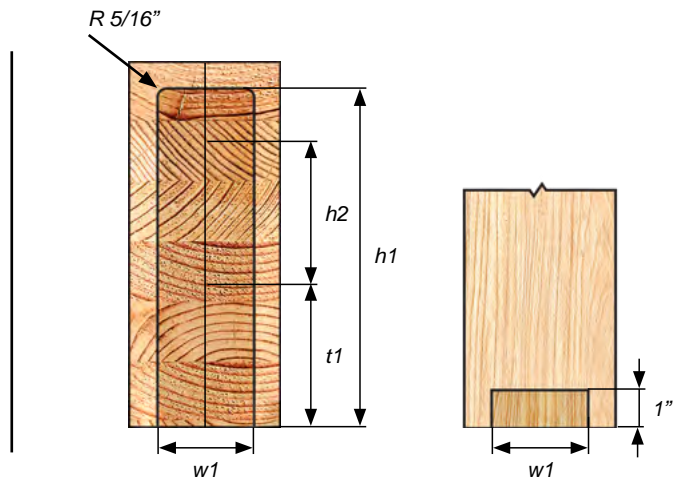

Section View

Bottom View

Secondary Member

Table 1.8 - Routing in Secondary Member - Requirements

Connector	h1	h2	t1	t2	min. d1	min. w1
	in.					
GIGANT 120 x 40	$a_{sec} + 4.638$	2.146	$a_{sec} + 1.457$	$a_{main} + 1.457$	3.543	1.685
GIGANT 150 x 40	$a_{sec} + 5.937$	3.524	$a_{sec} + 1.496$	$a_{main} + 1.496$	3.543	1.685
GIGANT 180 x 40	$a_{sec} + 7.197$	4.783	$a_{sec} + 1.516$	$a_{main} + 1.516$	3.543	1.685

Notes:

1. a_{main} refers to the top edge distance in the Primary Member where reinforcement is not required.
2. a_{sec} refers to the bottom edge distance in the Secondary Member where reinforcement is not required.
3. Tabulated values for h1 and w1 have been oversized by 1/32".
4. Tabulated d1 values include an additional 3/8" between tip of the screw and beam edge to avoid screw blow out.
5. Refer to the Geometry Requirement tables for each respective Beam Hanger System.



WIDC - UNBC

Prince George, British Columbia

RICON S VS

Pre-Engineered Post to Beam Connector

The RICON S VS connectors are ICC Approved pre-engineered post-to-beam connectors manufactured from mild steel with a welded collar bolt. They consist of two identical parts, and are suitable for uses in mass timber, timber framing and heavy timber construction. The RICON S VS Series have been extensively tested for the North American Market.



Pre-Installable

Pre-installable in controlled shop environment for a faster on-site installation



Drop-in Installation

A fast, streamlined & repeatable installation process that significantly enhances efficiency



Fully Concealable

Easy to conceal connections that enhance architectural wood features



Fire Resistance Rated

Fire Resistance Rating achievable up to 3 hours of exposure as per TR-10



Interstory Drift Performance Tested

Quasi-static rotational testing performed on the connector



Wood/Steel/Concrete Compatible

Can be installed in various configurations, wood/wood, steel/wood, concrete/wood

CERTIFICATIONS



ICC
EVALUATION
SERVICE®

ICC-ESR-4300

ISO 50001

Energy
Management
System



ETA-10/0189 2019

RICON S VS Hardware

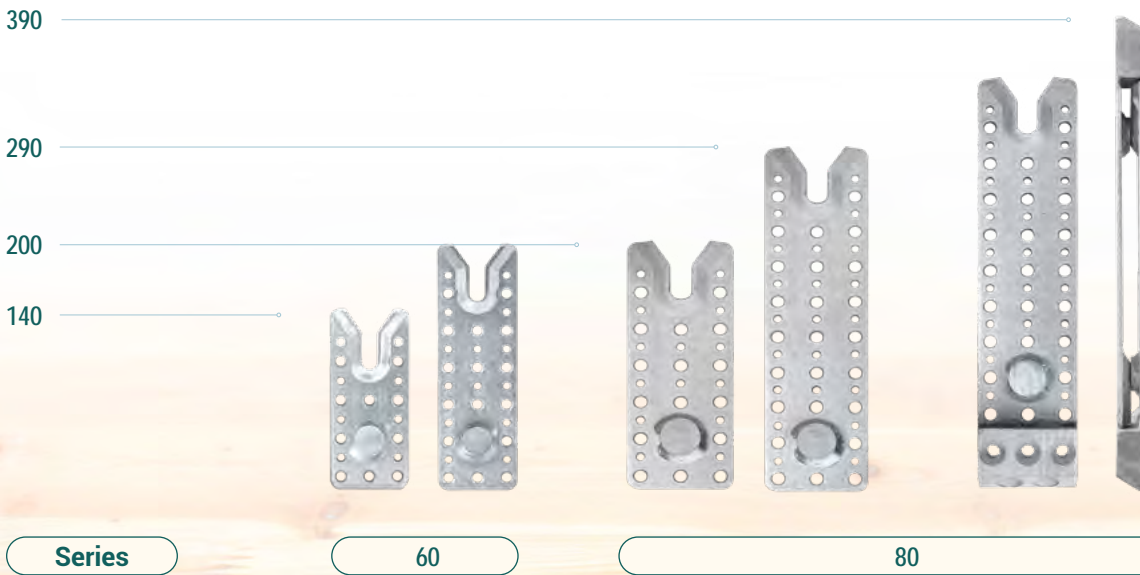

Note:
1. Product kit includes two identical connector plates.

Fastener - ASSY VG CSK

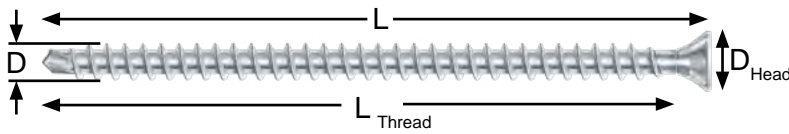

Item #	Type	D		L		L _{Thread}		D _{Head}		Bit
		in.	[mm]	in.	[mm]	in.	[mm]	in.	[mm]	
CSK0880	ASSY VG CSK	5/16"	[8]	3-1/8"	[80]	2-1/2"	[61]	0.591	[15]	RW 40
CSK08160				6-1/4"	[160]	5-5/8"	[143]			
CSK10100		3/8"	[10]	4"	[100]	3"	[77]	0.787	[20]	RW 50
CSK10200				7-7/8"	[200]	7-1/4"	[185]			

- Notes:
1. Use 6-1/4" or 7-7/8" screw into the end grain of secondary member.
 2. The suggested maximum installation torque for the 5/16" diameter VG CSK screw is 13.57 lb-ft.
 3. The suggested maximum installation torque for the 3/8" diameter VG CSK screw is 26.55 lb-ft.

RICON S VS 140 x 60

Connector Parameters and Dimensions

Compatible Materials

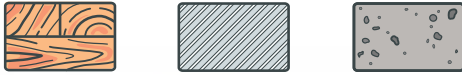

Installation Possibilities

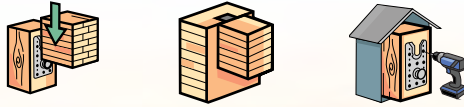

Testing & Certification

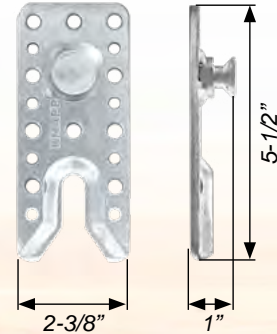

Table 2.1 Allowable Loads for RICON S VS 140 x 60

Item	Min. Beam Section	Specific Gravity [G]	Fasteners				Allowable Down Load [lb]
			Primary Member		Secondary Member		
			Type	Qty.	Type	Qty.	
Single RICON S VS 140x60	4" x 11-5/16"	≥ 0.50	VG CSK 5/16" x 3-1/8"	10	VG CSK 5/16" x 6-1/4"	10	3,780
Double RICON S VS 140x60	6-3/4" x 11-5/16"	≥ 0.50	VG CSK 5/16" x 3-1/8"	20	VG CSK 5/16" x 6-1/4"	20	6,410

Notes:

1. Connection design must meet all relevant requirements of the General Notes to the Designer section.
2. Allowable loads provided in this table are applicable for wood-to-wood connections only.
3. Allowable Down Load in SPF (G=0.42) available upon request.
4. Screw installation must follow the patterns presented in Installation and Tolerances section.

Table 2.2 Minimum and Maximum Distances (a_{main} , a_{sec})

Beam Depth	a_{max}
11-5/16"	1-13/16"
12"	2-1/32"
13-1/2"	2-15/32"
15"	2-15/16"
16-1/2"	3-3/8"
18"	3-13/16"
19-1/2"	4-9/32"
21"	4-23/32"
22-1/2"	5-3/16"
24"	5-5/8"

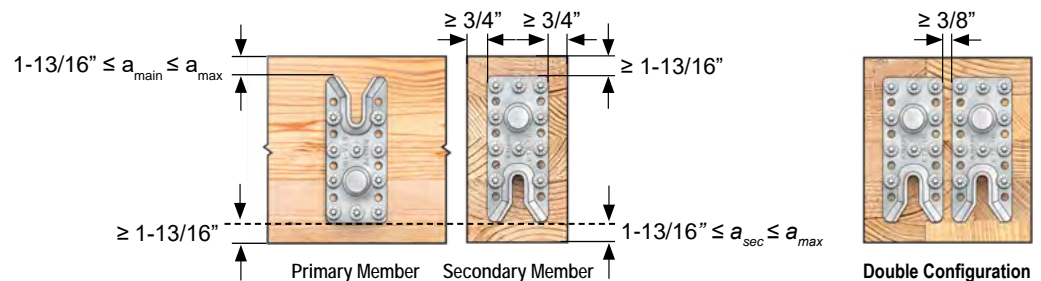

1. Maximum distances do not apply to primary post/column members (a_{main}), where the wood grain direction is parallel to the line of the force.
2. The Design Engineer may interpolate or extrapolate maximum values for a_{main} and a_{sec} for beam sizes not listed in the table.

RICON S VS 200 x 60

Connector Parameters and Dimensions

Compatible Materials

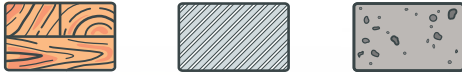

Installation Possibilities

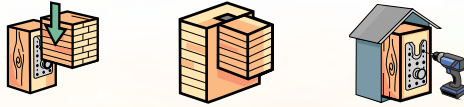

Testing & Certification

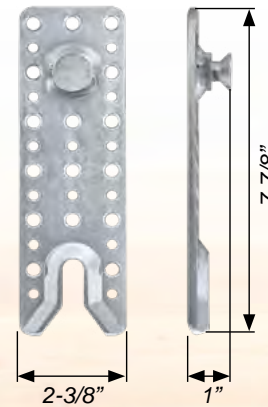

Table 2.3 Allowable Loads for RICON S VS 200 x 60

Item	Min. Beam Section	Specific Gravity [G]	Fasteners				Allowable Down Load [lb]
			Primary Member		Secondary Member		
			Type	Qty.	Type	Qty.	
Single RICON S VS 200x60	4" x 11-1/2"	≥ 0.50	VG CSK 5/16" x 3-1/8"	16	VG CSK 5/16" x 6-1/4"	16	4,780
Double RICON S VS 200x60	6-3/4" x 11-1/2"	≥ 0.50	VG CSK 5/16" x 3-1/8"	32	VG CSK 5/16" x 6-1/4"	32	8,120

Notes:

1. Connection design must meet all relevant requirements of the General Notes to the Designer section.
2. Allowable loads provided in this table are applicable for wood-to-wood connections only.
3. Allowable Down Load in SPF (G=0.42) available upon request.
4. Screw installation must follow the patterns presented in Installation and Tolerances section.

Table 2.4 Minimum and Maximum Distances (a_{main} , a_{sec})

Beam Depth	a_{max}
11-1/2"	1-7/8"
12"	2-1/32"
13-1/2"	2-15/32"
15"	2-15/16"
16-1/2"	3-3/8"
18"	3-13/16"
19-1/2"	4-9/32"
21"	4-23/32"
22-1/2"	5-3/16"
24"	5-5/8"

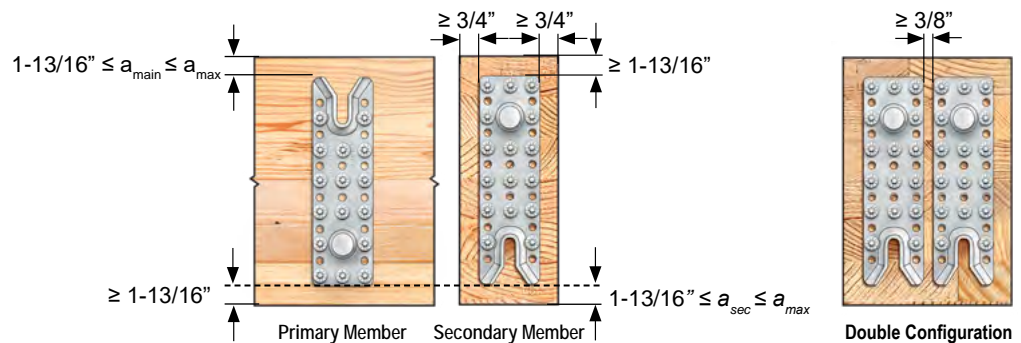

1. Maximum distances do not apply to primary post/column members (a_{main}), where the wood grain direction is parallel to the line of the force.
2. The Design Engineer may interpolate or extrapolate maximum values for a_{main} and a_{sec} for beam sizes not listed in the table.

RICON S VS 200 x 80

Connector Parameters and Dimensions

Compatible Materials

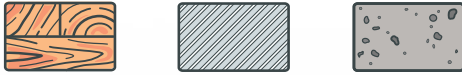

Installation Possibilities

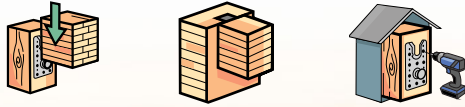

Testing & Certification

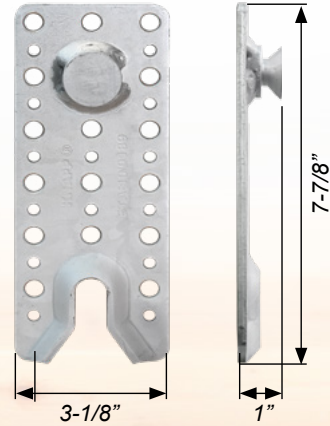

Table 2.5 Allowable Loads for RICON S VS 200 x 80

Item	Min. Beam Section	Specific Gravity [G]	Fasteners				Allowable Down Load [lb]
			Primary Member		Secondary Member		
			Type	Qty.	Type	Qty.	
Single RICON S VS 200x80	4-3/4" x 13-1/8"	≥ 0.50	VG CSK 3/8" x 4"	16	VG CSK 3/8" x 7-7/8"	16	6,880
Double RICON S VS 200x80	8-1/4" x 13-1/8"	≥ 0.50	VG CSK 3/8" x 4"	32	VG CSK 3/8" x 7-7/8"	32	12,030

Notes:

1. Connection design must meet all relevant requirements of the General Notes to the Designer section.
2. Allowable loads provided in this table are applicable for wood-to-wood connections only.
3. Allowable Down Load in SPF (G=0.42) available upon request.
4. Screw installation must follow the patterns presented in Installation and Tolerances section.

Table 2.6 Minimum and Maximum Distances (a_{main} , a_{sec})

Beam Depth	a_{max}
13-1/8"	2-3/8"
13-1/2"	2-15/32"
15"	2-15/16"
16-1/2"	3-3/8"
18"	3-13/16"
19-1/2"	4-9/32"
21"	4-23/32"
22-1/2"	5-3/16"
24"	5-5/8"
25-1/2"	6-1/16"

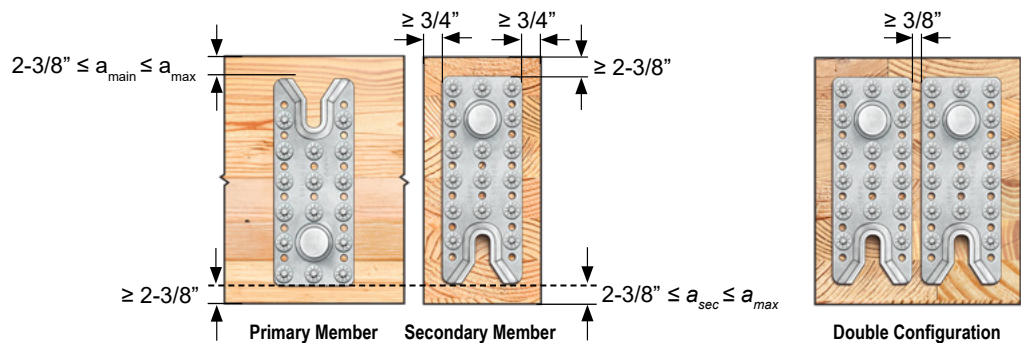

1. Maximum distances do not apply to primary post/column members (a_{main}), where the wood grain direction is parallel to the line of the force.
2. The Design Engineer may interpolate or extrapolate maximum values for a_{main} and a_{sec} for beam sizes not listed in the table.

RICON S VS 290 x 80

Connector Parameters and Dimensions

Compatible Materials

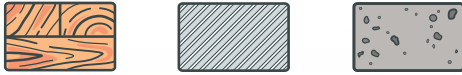

Installation Possibilities

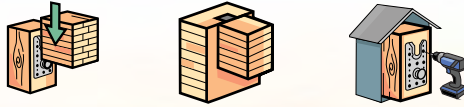

Testing & Certification



ICC-ESR-4300



ETA-10/0189 2019

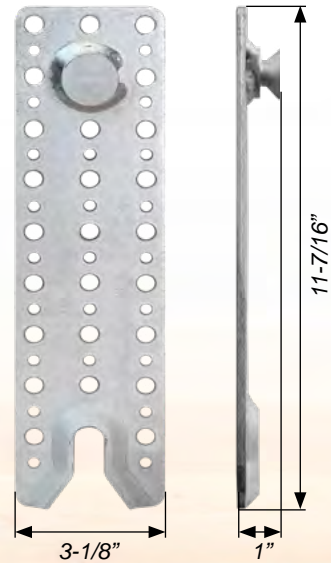

Table 2.7 Allowable Loads for RICON S VS 290 x 80

Item	Min. Beam Section	Specific Gravity [G]	Fasteners				Allowable Down Load [lb]
			Primary Member		Secondary Member		
			Type	Qty.	Type	Qty.	
Single RICON S VS 290x80	4-3/4" x 16-3/16"	≥ 0.50	VG CSK 3/8" x 4"	20	VG CSK 3/8" x 7-7/8"	20	8,900
Double RICON S VS 290x80	8-1/4" x 16-3/16"	≥ 0.50	VG CSK 3/8" x 4"	40	VG CSK 3/8" x 7-7/8"	40	15,570

Notes:

1. Connection design must meet all relevant requirements of the General Notes to the Designer section.
2. Allowable loads provided in this table are applicable for wood-to-wood connections only.
3. Allowable Down Load in SPF (G=0.42) available upon request.
4. Screw installation must follow the patterns presented in Installation and Tolerances section.

Table 2.8 Minimum and Maximum Distances (a_{main} , a_{sec})

Beam Depth	a_{max}
16-3/16"	3-9/32"
16-1/2"	3-3/8"
18"	3-13/16"
19-1/2"	4-9/32"
21"	4-23/32"
22-1/2"	5-3/16"
24"	5-5/8"
25-1/2"	6-1/16"
27"	6-17/32"
28-1/2"	6-31/32"

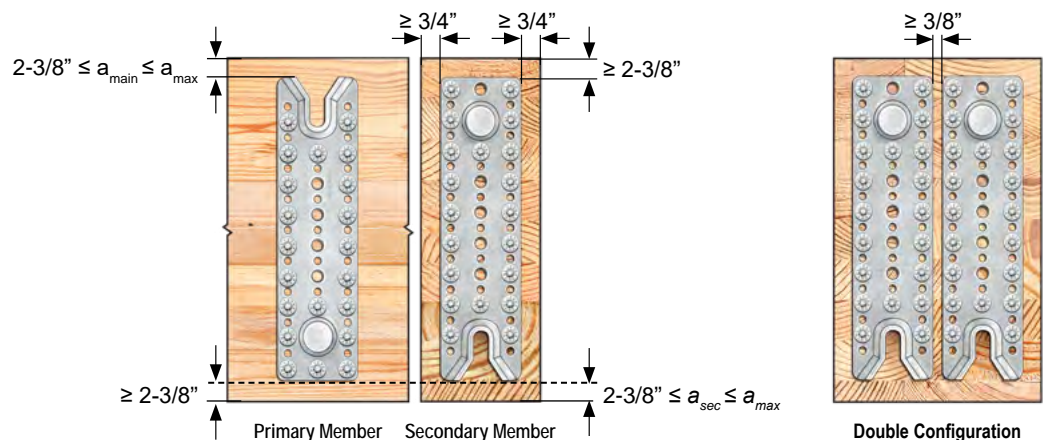

1. Maximum distances do not apply to primary post/column members (a_{main}), where the wood grain direction is parallel to the line of the force.
2. The Design Engineer may interpolate or extrapolate maximum values for a_{main} and a_{sec} for beam sizes not listed in the table.

RICON S VS XL 390 x 80

Connector Parameters and Dimensions

Compatible Materials

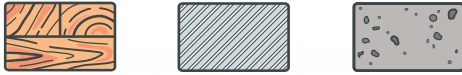

Installation Possibilities

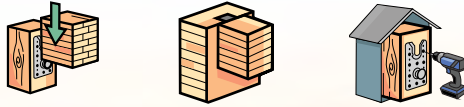

Testing & Certification



ICC-ESR-4300



ETA-10/0189 2019

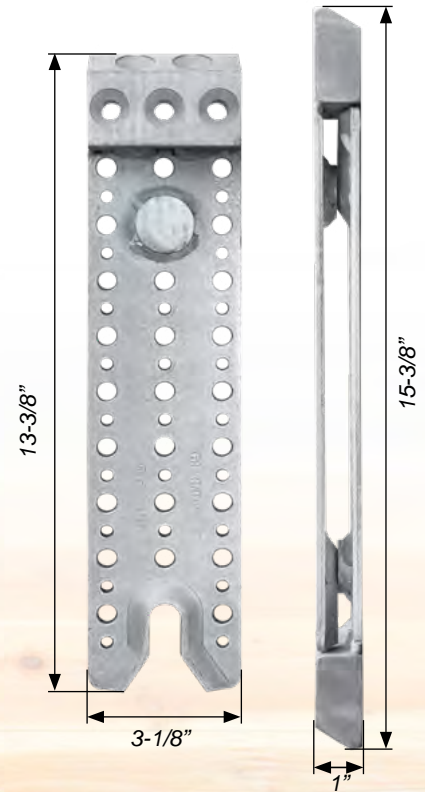

Table 2.9 Allowable Loads for RICON S VS XL 390 x 80

Item	Min. Beam Section	Specific Gravity [G]	Fasteners				Allowable Down Load [lb]
			Primary Member		Secondary Member		
			Type	Qty.	Type	Qty.	
Single RICON S VS XL 390x80	4-3/4" x 18-1/2"	≥ 0.50	VG CSK 3/8" x 4"	28	VG CSK 3/8" x 7-7/8"	28	15,000
			VG CSK 3/8" x 7-7/8"	2	VG CSK 3/8" x 7-7/8"	2	
Double RICON S VS XL 390x80	8-1/4" x 18-1/2"	≥ 0.50	VG CSK 3/8" x 4"	56	VG CSK 3/8" x 7-7/8"	56	26,240
			VG CSK 3/8" x 7-7/8"	4	VG CSK 3/8" x 7-7/8"	4	

Notes:

1. Connection design must meet all relevant requirements of the General Notes to the Designer section.
2. Allowable loads provided in this table are applicable for wood-to-wood connections only.
3. Allowable Down Load in SPF (G=0.42) available upon request.
4. Screw installation must follow the patterns presented in Installation and Tolerances section.

Table 2.10 Minimum and Maximum Distances (a_{main} , a_{sec})

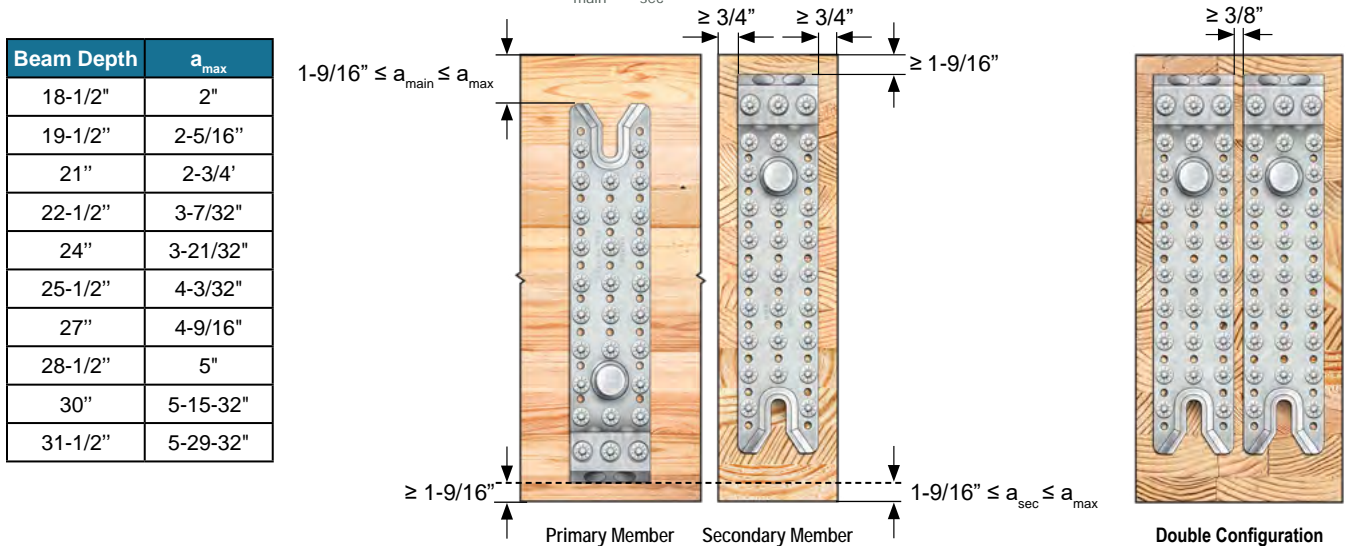

1. Maximum distances do not apply to primary post/column members (a_{main}), where the wood grain direction is parallel to the line of the force.
2. The Design Engineer may interpolate or extrapolate maximum values for a_{main} and a_{sec} for beam sizes not listed in the table.

Installation and Tolerances - Requirements

Beam Length Tolerances

Glulam beams are often produced oversized and cut to size for squareness and length within the tolerances stated by the wood fabricator. Detailers should be aware of the pre- and post-cut lengths when estimating the gap between members and the required housing depth of 0.985" for the RICON S VS concealed beam hangers.

Screw Installation Details: RICON S VS Versus RICON S VS XL

RICON S VS 60 Series

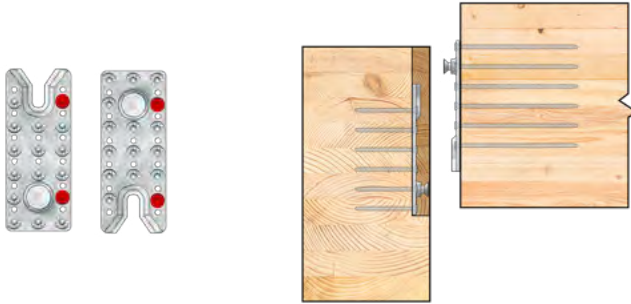

- Main member fasteners (into side grain) ASSY VG CSK 5/16" x 3-1/8"
- Side member fasteners (into end grain) ASSY VG CSK 5/16" x 6-1/4"
- Connector mounted flush in the housing.

RICON S VS 80 Series

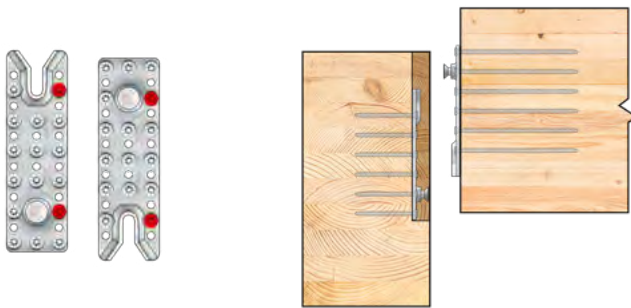

- Main member fasteners (into side grain) ASSY VG CSK 3/8" x 4"
- Side member fasteners (into end grain) ASSY VG CSK 3/8" x 7-7/8"
- Connector mounted flush in the housing.

RICON S VS 80 Series XL

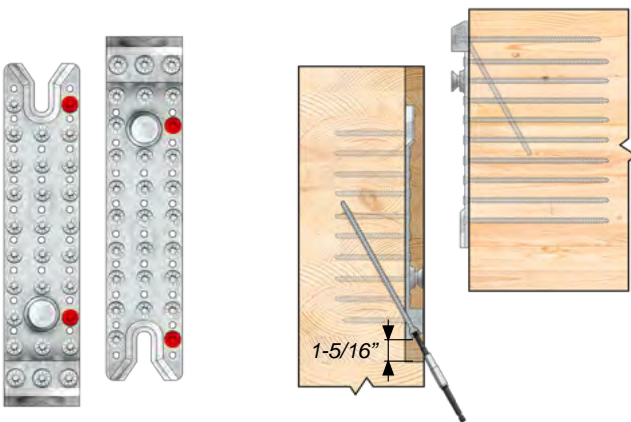

- Main member fasteners (into side grain) ASSY VG CSK 3/8" x 4" + inclined ASSY VG CSK 3/8" x 7-7/8"
- Side member fasteners (into end grain) ASSY VG CSK 3/8" x 7-7/8" + inclined ASSY VG CSK 3/8" x 7-7/8"
- Additional clearance of 1-5/16" (33 mm) required below the connector. A bit extender is suggested to be used to facilitate installation of inclined fastener.
- This additional housing depth requirement must be accounted for during design. For FRR the cavity can be filled with non combustible filler material.

Routing in Primary Member Only

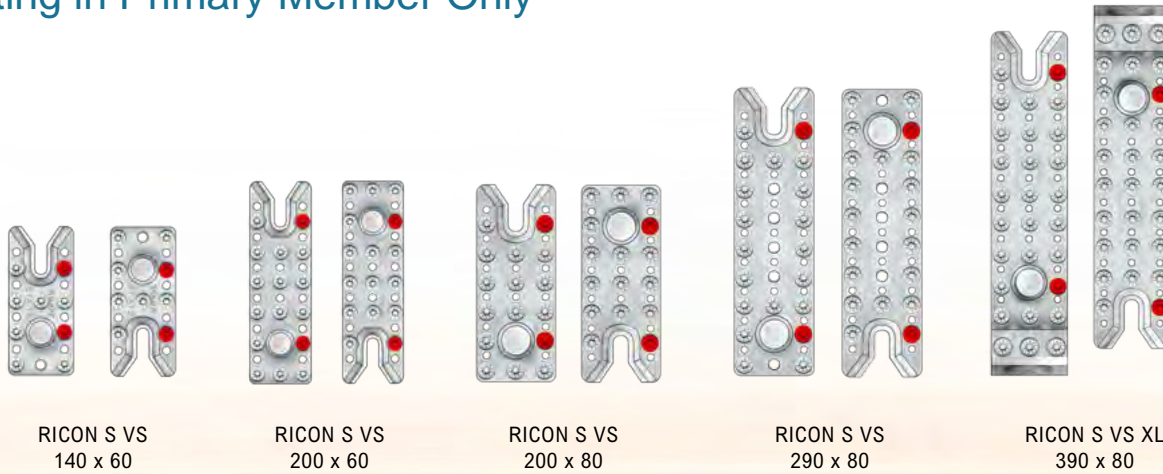

Notes:

1. The red markings indicate the positioning screws which should be aligned with the pre-drilled positioning holes on the wood members which are also indicated in red in the following figures.
2. All concealed installations are suggested to be field verified.

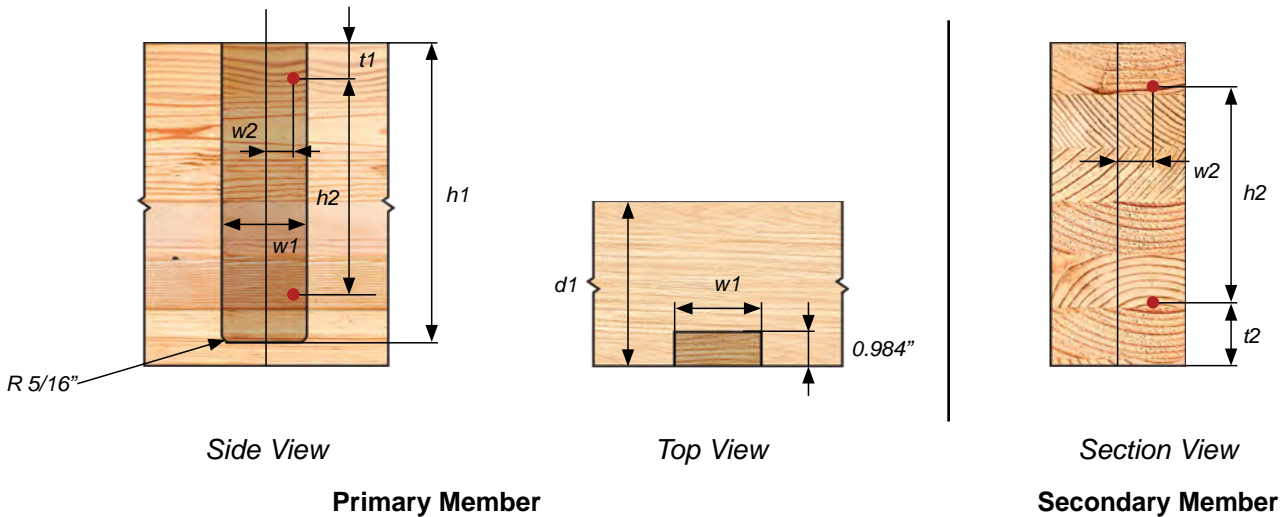

Table 2.11 Routing in Primary Member - Requirements RICON S VS

Connector	h1	h2	t1	t2	min. d1	min. w1	w2
	in.						
Ricon S VS 140 X 60	$a_{main} + 5.543$	2.362	$a_{main} + 1.575$	$a_{sec} + 1.575$	4.191	2.393	0.866
Ricon S VS 200 X 60	$a_{main} + 7.905$	4.724	$a_{main} + 1.575$	$a_{sec} + 1.575$	4.191	2.393	0.866
Ricon S VS 200 X 80	$a_{main} + 7.905$	4.724	$a_{main} + 1.575$	$a_{sec} + 1.575$	4.915	3.181	1.181
Ricon S VS 290 X 80	$a_{main} + 11.449$	8.268	$a_{main} + 1.575$	$a_{sec} + 1.575$	4.915	3.181	1.181
Ricon S VS XL 390 X 80	$a_{main} + 16.646$	8.268	$a_{main} + 3.543$	$a_{sec} + 3.543$	4.915	3.181	1.181

Notes:

1. a_{main} refers to the top edge distance in the Primary Member where reinforcement is not required.
2. a_{sec} refers to the bottom edge distance in the Secondary Member where reinforcement is not required.
3. Tabulated values for h1 and w1 have been oversized by 1/32".
4. Tabulated h1 value for the RICON S VS XL includes a 1-5/16" gap below the connector to allow the installation of inclined fasteners.
5. Tabulated d1 values include an additional 3/8" between tip of the screw and beam edge to avoid screw blow out.
6. Refer to the Geometry Requirement tables for each respective Beam Hanger System.

Routing in Secondary Member Only

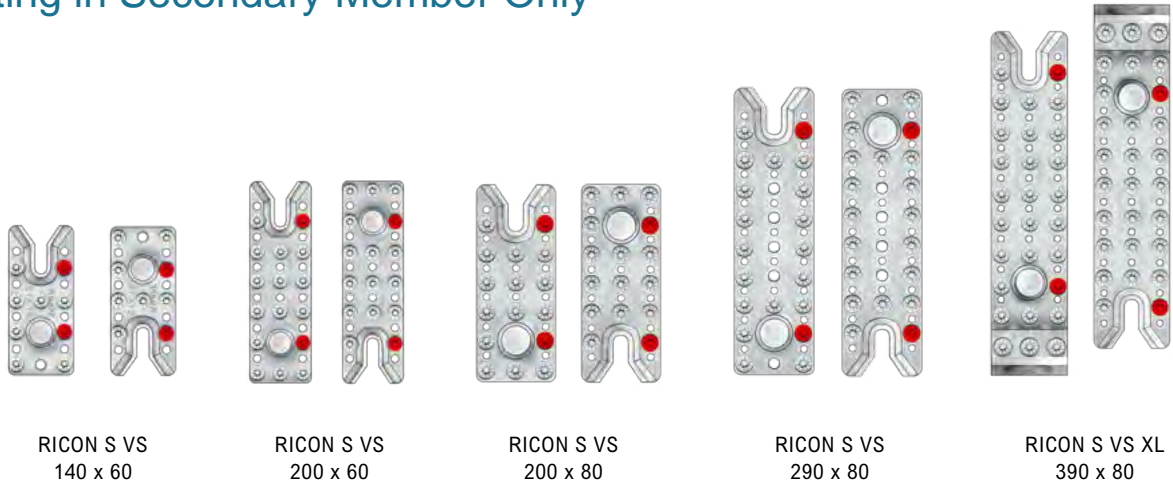

Notes:

1. The red markings indicate the positioning screws which should be aligned with the pre-drilled positioning holes on the wood members which are also indicated in red in the following figures.
2. All concealed installations are suggested to be field verified.

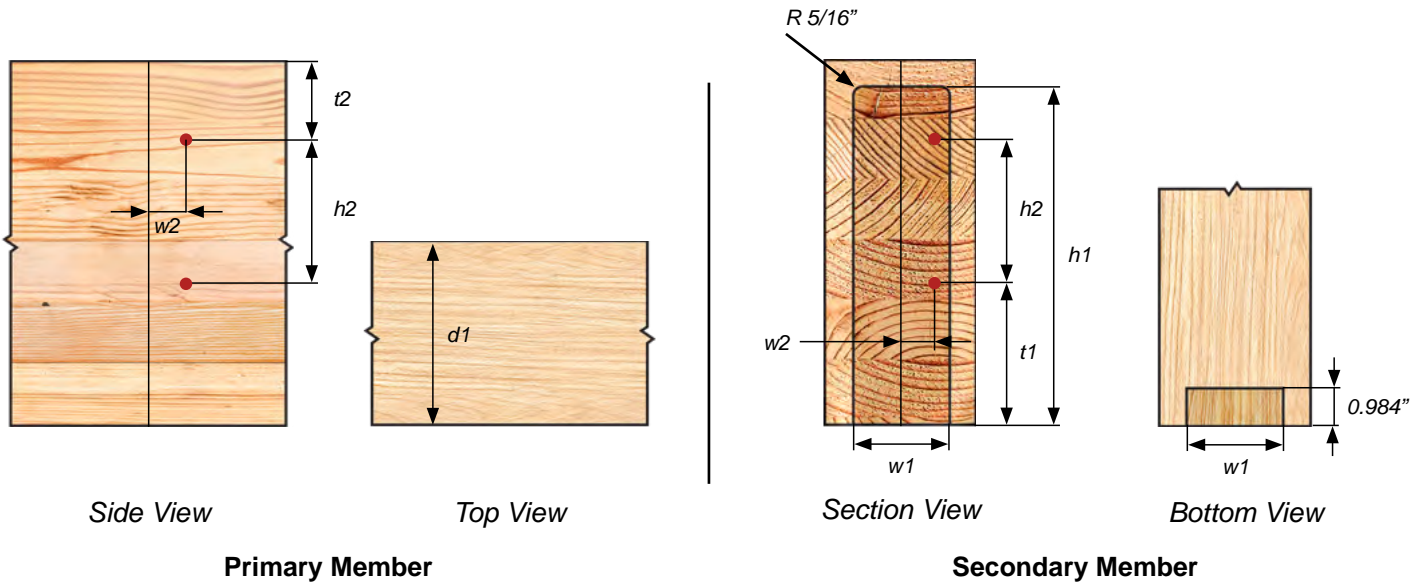

Table 2.12 Routing in Secondary Member - Requirements RICON S VS

Connector	h1	h2	t1	t2	min. d1	min. w1	w2
	in.						
Ricon S VS 140 X 60	$a_{sec} + 5.543$	2.362	$a_{sec} + 1.575$	$a_{main} + 1.575$	3.206	2.393	0.866
Ricon S VS 200 X 60	$a_{sec} + 7.905$	4.724	$a_{sec} + 1.575$	$a_{main} + 1.575$	3.206	2.393	0.866
Ricon S VS 200 X 80	$a_{sec} + 7.905$	4.724	$a_{sec} + 1.575$	$a_{main} + 1.575$	3.931	3.181	1.181
Ricon S VS 290 X 80	$a_{sec} + 11.449$	8.268	$a_{sec} + 1.575$	$a_{main} + 1.575$	3.931	3.181	1.181
Ricon S VS XL 390 X 80	$a_{sec} + 16.646$	8.268	$a_{sec} + 3.543$	$a_{main} + 3.543$	3.931	3.181	1.181

Notes:

1. a_{main} refers to the top edge distance in the Primary Member where reinforcement is not required.
2. a_{sec} refers to the bottom edge distance in the Secondary Member where reinforcement is not required.
3. Tabulated values for h1 and w1 have been oversized by 1/32".
4. Tabulated h1 value for the RICON S VS XL includes a 1-5/16" gap below the connector to allow the installation of inclined fasteners.
5. Tabulated d1 values include an additional 3/8" between tip of the screw and beam edge to avoid screw blow out.
6. Refer to the Geometry Requirement tables for each respective Beam Hanger System.



Rocky Ridge YMCA

Calgary, Alberta



Ritchie Market

Edmonton, Alberta

MEGANT

Pre-Engineered Connection System

The MEGANT connector is a pre-engineered post to beam connector, a system manufactured from aluminum with connector plates and threaded rod to secure the connection. The MEGANT connectors are tested for the North American Market.



Pre-Installable

Pre-installable in controlled shop environment for a faster on-site installation



Multi-Direction Installation

Connector installable from all directions (top, bottom, and sides)



Fully Concealable

Easy to conceal connections that enhance architectural wood features



Fire Resistance Rated

Fire Resistance Rating achievable up to 3 hours of exposure as per TR-10



Interstory Drift Tested

Quasi-static rotational testing performed on the connector



Allowable Load Derived from Tests

Allowable loads for the connector are derived in accordance with testing similar to ASTM D 7147

CERTIFICATIONS

ISO 50001

Energy Management System



ETA-15/0667 2019

MEGANT Hardware

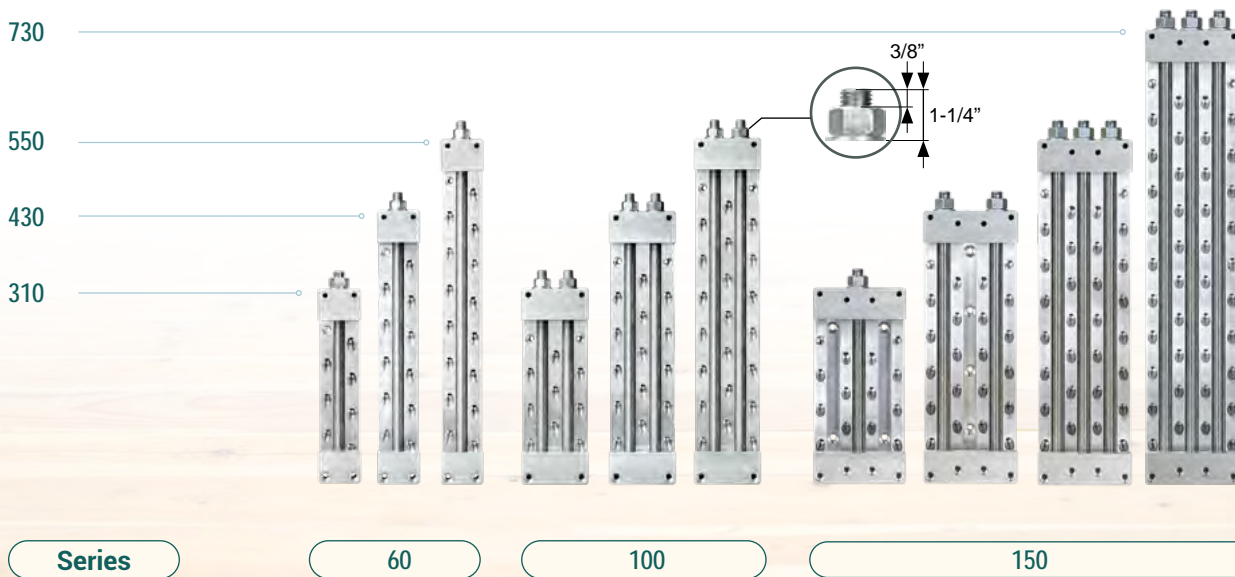

Note:
 1. The suggested installation torque of the top nut for the MEGANT is 29.5 lb-ft

Product Kit Details

Number	Description
1	Hex Nut
2	Washer
3	Top Clamping Jaws (Without Thread)
4	Threaded Rod
5	Connector Plates
6	Bottom Clamping Jaws (Threaded)

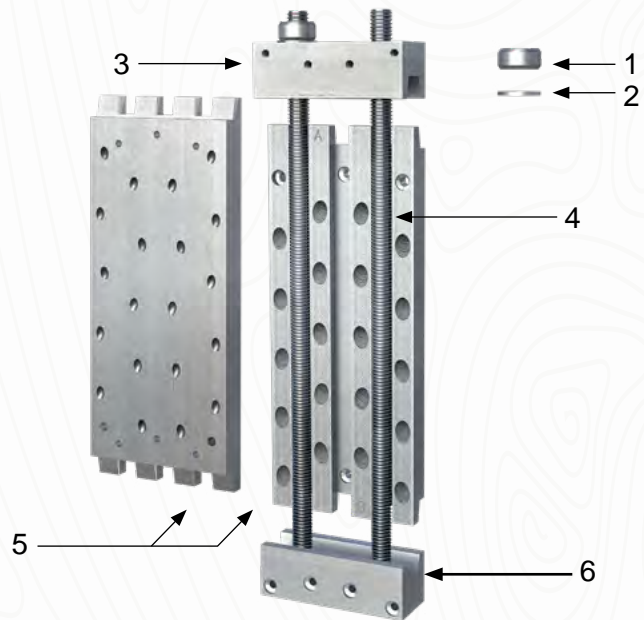

Fastener - ASSY VG CSK

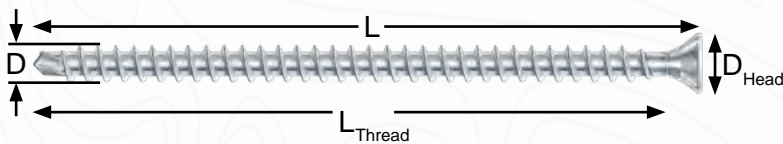

Item #	Type	D		L		L _{Thread}		D _{Head}		Bit
		in.	[mm]	in.	[mm]	in.	[mm]	in.	[mm]	
CSK08160	ASSY VG CSK	5/16"	[8]	6-1/4"	[160]	5-5/8"	[143]	0.591	[15]	RW 40

Note:
 1. The suggested maximum installation torque for the 5/16" diameter VG CSK screw is 13.57 lb-ft.

MEGANT Pre-Drilling Jig

The MEGANT pre-drilling jig is a simple and efficient tool specifically designed to allow for a precise predrilling of the MEGANT inclined fasteners VG CSK 5/16" x 6-1/4" (8 x 160 mm), allowing for an accurate fastener penetration path. The MEGANT pre-drilling jig can be used in combination with 3/16" (5mm) diameter drill bits.



MEGANT Beam Hanger Force Transfer

The following figures outline the installation of the MEGANT connector and highlight the flow of forces through the various components. This is presented to aid in understanding why the fasteners and connector must be installed as specified.

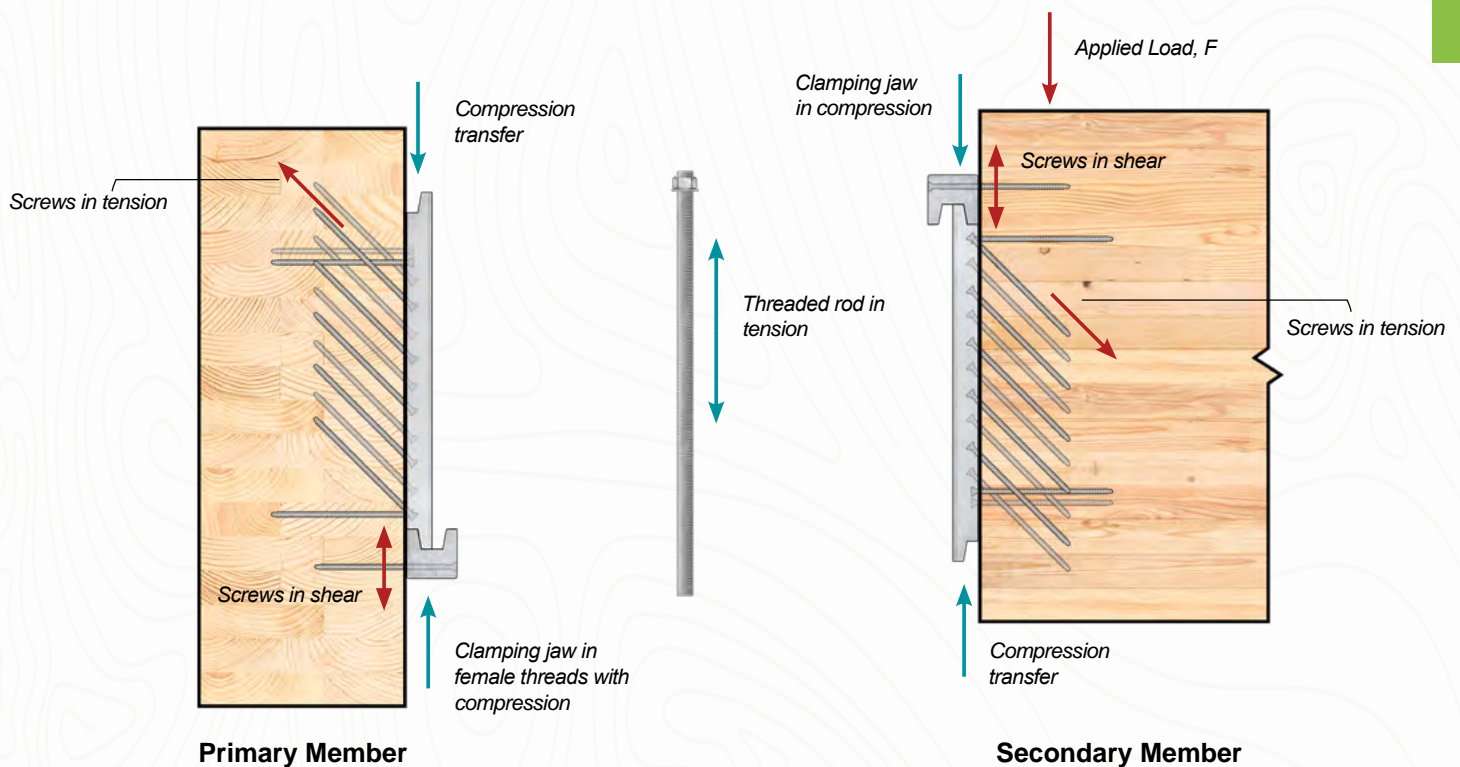

MEGANT 310 x 60

Connector Parameters and Dimensions

Compatible Materials



Installation Possibilities

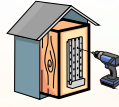
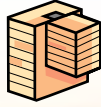
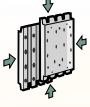

Testing & Certification

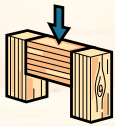

ETA-15/0667 2019

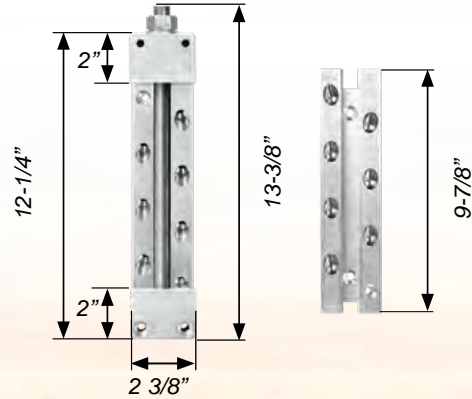

Table 3.1 Allowable Loads for MEGANT 310 x 60

Item	Min. Beam Section	Specific Gravity [G]	Fasteners		Threaded Rod	Allowable Down Load [lb]
			Type	Qty.		
MEGANT 310x60	4" x 15-3/4"	0.42 [SPF]	VG CSK 5/16" x 6-1/4"	24	1 pc of M20 x 340 [13-3/8"] Grade 8.8	7,220
		≥ 0.50	VG CSK 5/16" x 6-1/4"	24	1 pc of M20 x 340 [13-3/8"] Grade 8.8	8,180

Notes:

1. Connection design must meet all relevant requirements of the General Notes to the Designer section.
2. Screw installation must follow the patterns presented in the Installation and Tolerances section.

Table 3.2 Minimum and Maximum Distances (a_{main} , a_{sec})

Beam Depth	a_{max}
15-3/4"	2-3/8"
15-7/8"	2-7/16"
18"	4-1/2"
19-1/2"	5"
21"	5-3/8"
22-1/2"	5-7/8"
24"	6-1/4"

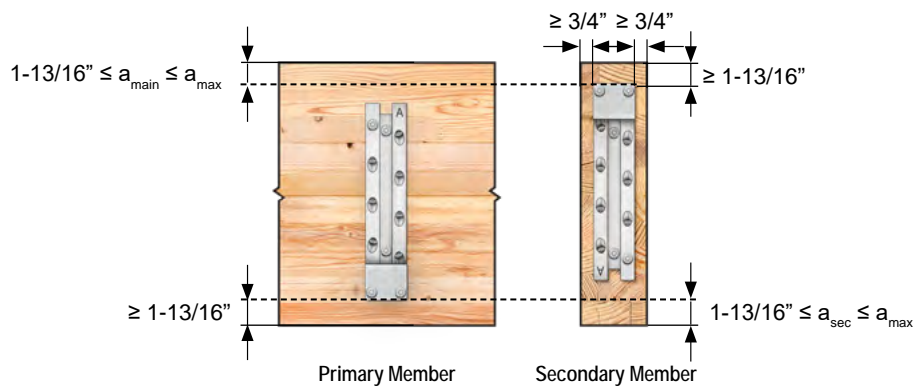

1. Maximum distances do not apply to primary post/column members (a_{main}), where the wood grain direction is parallel to the line of the force.
2. The Design Engineer may interpolate or extrapolate maximum values for a_{main} and a_{sec} for beam sizes not listed in the table.

MEGANT 430 x 60

Connector Parameters and Dimensions

Compatible Materials



Installation Possibilities

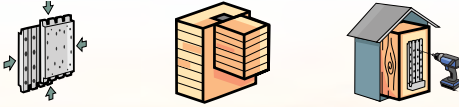

Testing & Certification

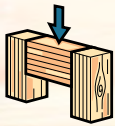

ETA-15/0667 2019

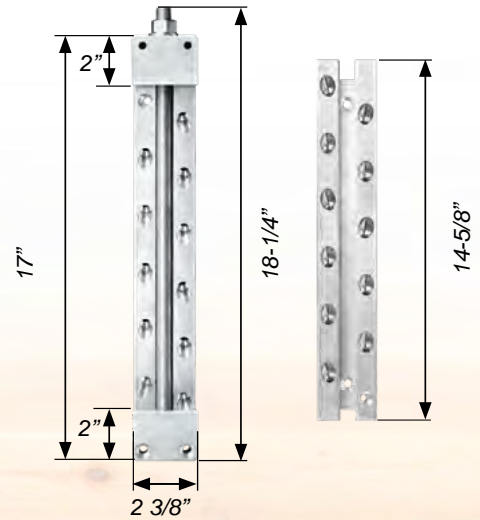

Table 3.3 Allowable Loads for MEGANT 430 x 60

Item	Min. Beam Section	Specific Gravity [G]	Fasteners		Threaded Rod	Allowable Down Load [lb]
			Type	Qty.		
MEGANT 430x60	4" x 20-1/2"	0.42 [SPF]	VG CSK 5/16" x 6-1/4"	32	1 pc of M20 x 460 [18-1/4"] Grade 8.8	11,350
		≥ 0.50	VG CSK 5/16" x 6-1/4"	32	1 pc of M20 x 460 [18-1/4"] Grade 8.8	12,830

Notes:

1. Connection design must meet all relevant requirements of the General Notes to the Designer section.
2. Screw installation must follow the patterns presented in the Installation and Tolerances section.

Table 3.4 Minimum and Maximum Distances (a_{main} , a_{sec})

Beam Depth	a_{max}
20-1/2"	2-3/8"
20-9/16"	2-7/16"
22-1/2"	4-3/8"
24"	5-7/8"
25-1/2"	6-3/4"
27"	7-1/4"
28-1/2"	7-3/4"
30"	8-1/8"
31-1/2"	8-5/8"
33"	9"

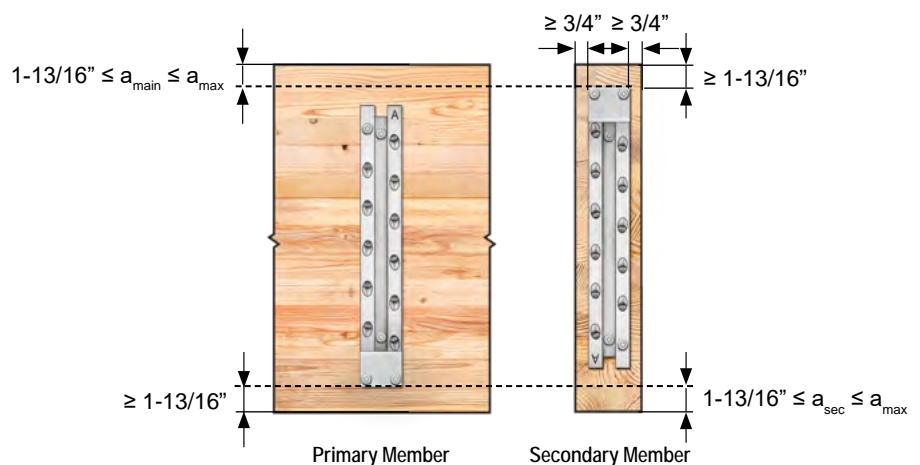

1. Maximum distances do not apply to primary post/column members (a_{main}), where the wood grain direction is parallel to the line of the force.
2. The Design Engineer may interpolate or extrapolate maximum values for a_{main} and a_{sec} for beam sizes not listed in the table.

MEGANT 550 x 60

Connector Parameters and Dimensions

Compatible Materials



Installation Possibilities

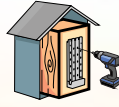
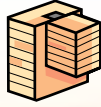
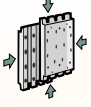

Testing & Certification

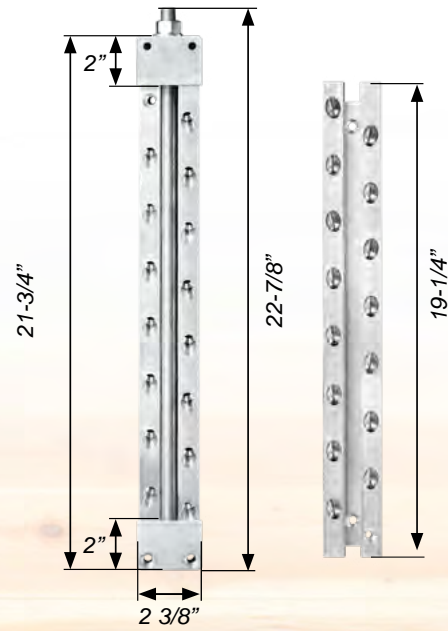
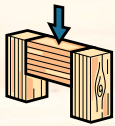

Table 3.5 Allowable Loads for MEGANT 550 x 60

Item	Min. Beam Section	Specific Gravity [G]	Fasteners		Threaded Rod	Allowable Down Load [lb]
			Type	Qty.		
MEGANT 550x60	4" x 25-1/4"	0.42 [SPF]	VG CSK 5/16" x 6-1/4"	40	1 pc of M20 x 580 [22-7/8"] Grade 8.8	12,830
		≥ 0.50	VG CSK 5/16" x 6-1/4"	40	1 pc of M20 x 580 [22-7/8"] Grade 8.8	12,830

Notes:

1. Connection design must meet all relevant requirements of the General Notes to the Designer section.
2. Screw installation must follow the patterns presented in the Installation and Tolerances section.

Table 3.6 Minimum and Maximum Distances (a_{main} , a_{sec})

Beam Depth	a_{max}
25-1/4"	2-3/8"
25-5/16"	2-7/16"
27"	4-1/8"
28-1/2"	5-5/8"
30"	7-1/8"
31-1/2"	8-5/8"
33"	9"
34-1/2"	9-1/2"
36"	9-7/8"
37-1/2"	10-1/4"

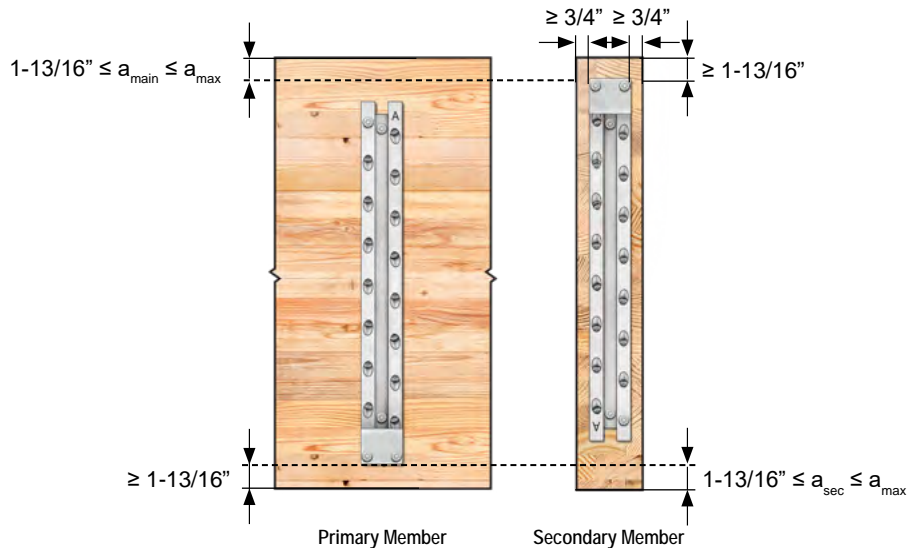

1. Maximum distances do not apply to primary post/column members (a_{main}), where the wood grain direction is parallel to the line of the force.
2. The Design Engineer may interpolate or extrapolate maximum values for a_{main} and a_{sec} for beam sizes not listed in the table.

MEGANT 310 x 100

Connector Parameters and Dimensions

Compatible Materials



Installation Possibilities

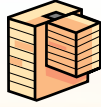
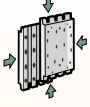

Testing & Certification

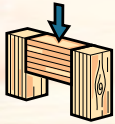

ETA-15/0667 2019

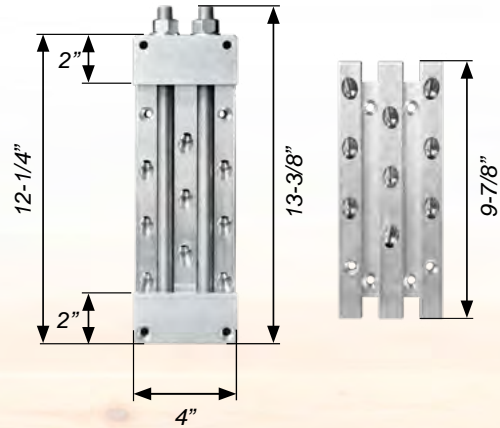

Table 3.7 Allowable Loads for MEGANT 310 x 100

Item	Min. Beam Section	Specific Gravity [G]	Fasteners		Threaded Rod	Allowable Down Load [lb]
			Type	Qty.		
MEGANT 310x100	5-5/8" x 15-3/4"	0.42 [SPF]	VG CSK 5/16" x 6-1/4"	34	2 pcs of M16 x 340 [13-3/8"] Grade 8.8	9,280
		≥ 0.50	VG CSK 5/16" x 6-1/4"	34	2 pcs of M16 x 340 [13-3/8"] Grade 8.8	10,510

Notes:

1. Connection design must meet all relevant requirements of the General Notes to the Designer section.
2. Screw installation must follow the patterns presented in the Installation and Tolerances section.

Table 3.8 Minimum and Maximum Distances (a_{main} , a_{sec})

Beam Depth	a_{max}
15- 3/4"	2-3/8"
15-7/8"	2-7/16"
18"	3-1/4"
19- 1/2"	3-3/4"
21"	4-1/4"
22- 1/2"	4-3/4"
24"	5-1/8"

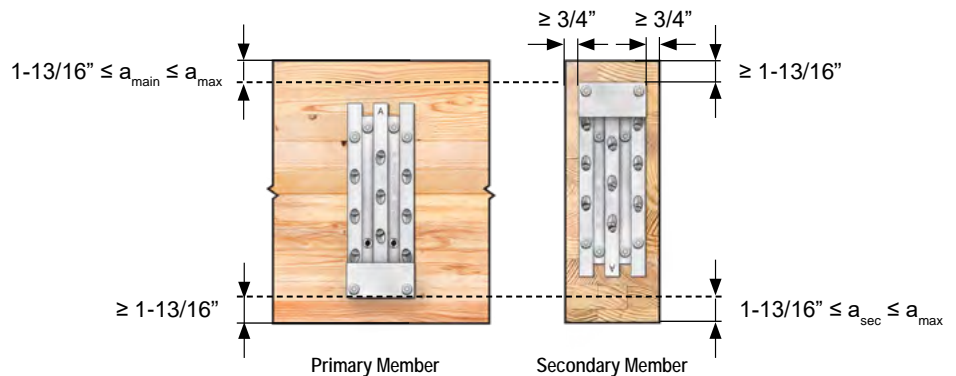

1. Maximum distances do not apply to primary post/column members (a_{main}), where the wood grain direction is parallel to the line of the force.
2. The Design Engineer may interpolate or extrapolate maximum values for a_{main} and a_{sec} for beam sizes not listed in the table.

MEGANT 430 x 100

Connector Parameters and Dimensions

Compatible Materials



Installation Possibilities

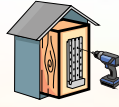
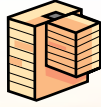
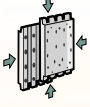

Testing & Certification

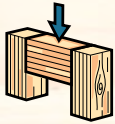

ETA-15/0667 2019

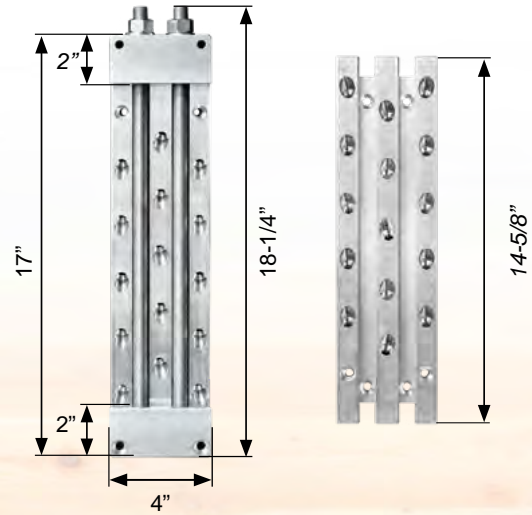

Table 3.9 Allowable Loads for MEGANT 430 x 100

Item	Min. Beam Section	Specific Gravity [G]	Fasteners		Threaded Rod	Allowable Down Load [lb]
			Type	Qty.		
MEGANT 430x100	5-5/8" x 20-7/8"	0.42 [SPF]	VG CSK 5/16" x 6-1/4"	46	2 pcs of M16 x 460 [18-1/4"] Grade 8.8	15,480
		≥ 0.50	VG CSK 5/16" x 6-1/4"	46	2 pcs of M16 x 460 [18-1/4"] Grade 8.8	17,530

Notes:

1. Connection design must meet all relevant requirements of the General Notes to the Designer section.
2. Screw installation must follow the patterns presented in the Installation and Tolerances section.

Table 3.10 Minimum and Maximum Distances (a_{main} , a_{sec})

Beam Depth	a_{max}
20-7/8"	2-3/4"
22-1/2"	4-3/8"
24"	5-1/8"
25-1/2"	5-5/8"
27"	6"
28-1/2"	6-1/2"
30"	6-7/8"
31-1/2"	7-3/8"
33"	7-3/4"

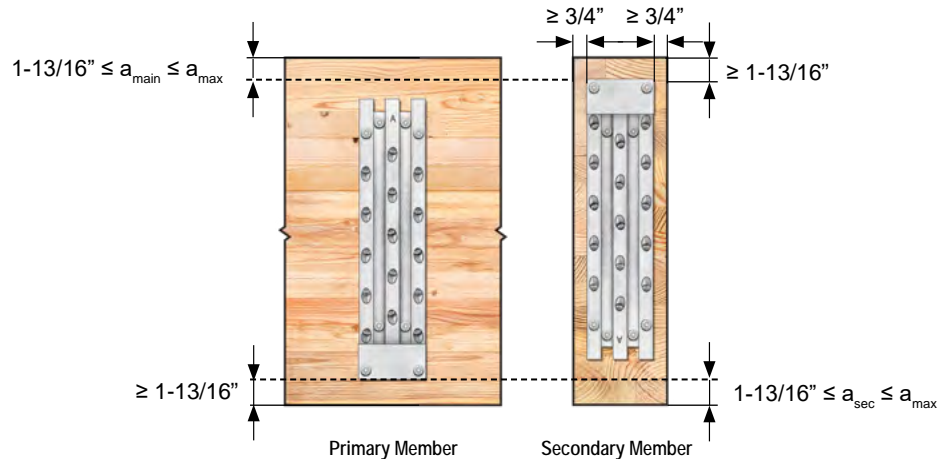

1. Maximum distances do not apply to primary post/column members (a_{main}), where the wood grain direction is parallel to the line of the force.
2. The Design Engineer may interpolate or extrapolate maximum values for a_{main} and a_{sec} for beam sizes not listed in the table.

MEGANT 550 x 100

Connector Parameters and Dimensions

Compatible Materials



Installation Possibilities

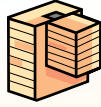
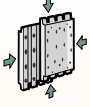

Testing & Certification

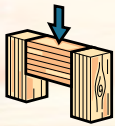

ETA-15/0667 2019

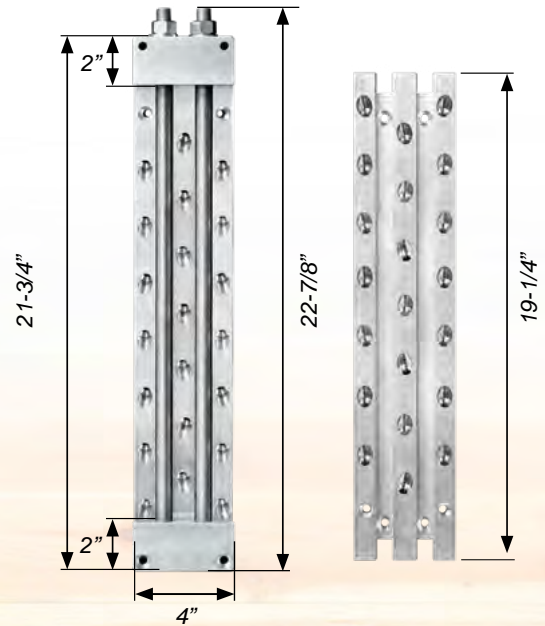

Table 3.11 Allowable Loads for MEGANT 550 x 100

Item	Min. Beam Section	Specific Gravity [G]	Fasteners		Threaded Rod	Allowable Down Load [lb]
			Type	Qty.		
MEGANT 550x100	5-5/8" x 25-5/8"	0.42 [SPF]	VG CSK 5/16" x 6-1/4"	58	2 pcs of M16 x 580 [22-7/8"] Grade 8.8	19,500
		≥ 0.50	VG CSK 5/16" x 6-1/4"	58	2 pcs of M16 x 580 [22-7/8"] Grade 8.8	19,500

Notes:

1. Connection design must meet all relevant requirements of the General Notes to the Designer section.
2. Screw installation must follow the patterns presented in the Installation and Tolerances section.

Table 3.12 Minimum and Maximum Distances (a_{main} , a_{sec})

Beam Depth	a_{max}
25-5/8"	2-3/4"
27"	4-1/8"
28-1/2"	5-5/8"
30"	6-7/8"
31-1/2"	7-3/8"
33"	7-3/4"
34-1/2"	8-1/4"
36"	8-3/4"
37-1/2"	9-1/4"
38-7/8"	9-5/8"

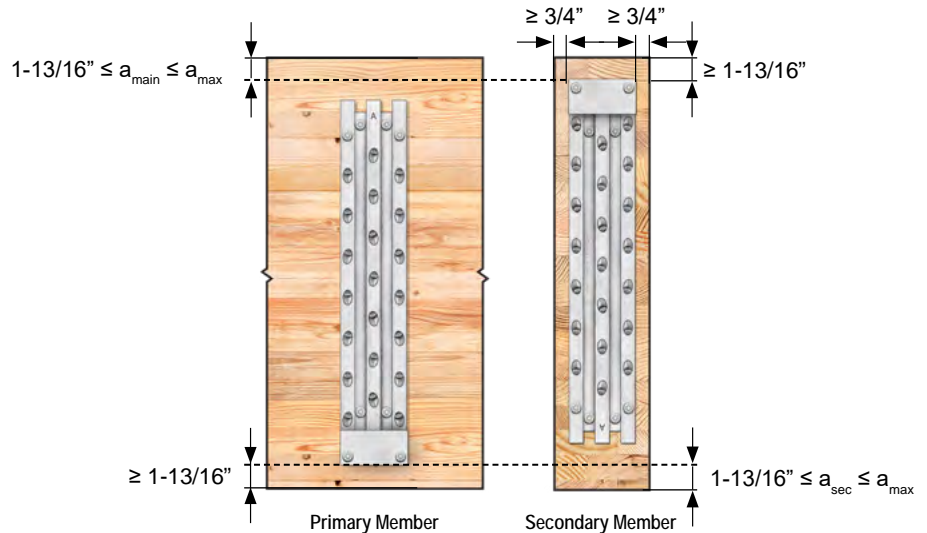

1. Maximum distances do not apply to primary post/column members (a_{main}), where the wood grain direction is parallel to the line of the force.
2. The Design Engineer may interpolate or extrapolate maximum values for a_{main} and a_{sec} for beam sizes not listed in the table.

MEGANT 310 x 150

Connector Parameters and Dimensions

Compatible Materials



Installation Possibilities

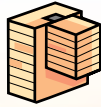
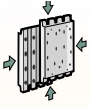

Testing & Certification

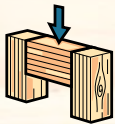

ETA-15/0667 2019

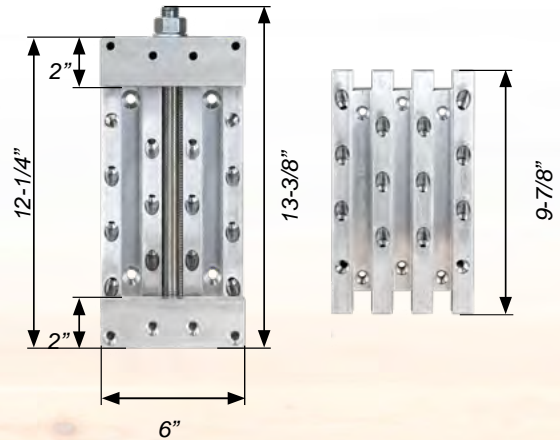

Table 3.13 Allowable Loads for MEGANT 310 x 150

Item	Min. Beam Section	Specific Gravity [G]	Fasteners		Threaded Rod	Allowable Down Load [lb]
			Type	Qty.		
MEGANT 310x150	7-1/2" x 15-3/4"	0.42 [SPF]	VG CSK 5/16" x 6-1/4"	48	1 pcs of M20 x 340 [13-3/8"] Grade 8.8	12,010
		≥ 0.50	VG CSK 5/16" x 6-1/4"	48	1 pcs of M20 x 340 [13-3/8"] Grade 8.8	13,600

Notes:

1. Connection design must meet all relevant requirements of the General Notes to the Designer section.
2. Screw installation must follow the patterns presented in the Installation and Tolerances section.

Table 3.14 Minimum and Maximum Distances (a_{main} , a_{sec})

Beam Depth	a_{max}
15-3/4"	2- 3/8"
15-7/8"	2- 7/16"
18"	3- 1/4"
19-1/2"	3- 3/4"
21"	4- 1/4"
22-1/2"	4- 3/4"
24"	5- 1/8"

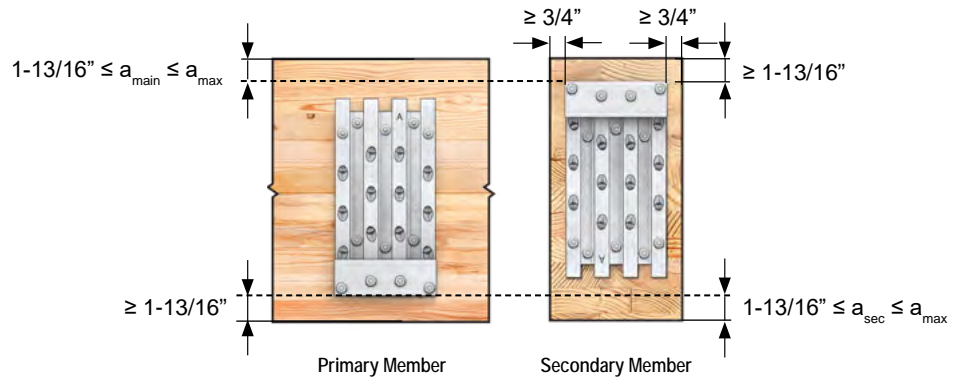

1. Maximum distances do not apply to primary post/column members (a_{main}), where the wood grain direction is parallel to the line of the force.
2. The Design Engineer may interpolate or extrapolate maximum values for a_{main} and a_{sec} for beam sizes not listed in the table.

MEGANT 430 x 150

Connector Parameters and Dimensions

Compatible Materials



Installation Possibilities

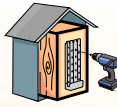
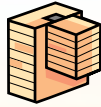
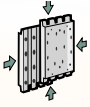

Testing & Certification

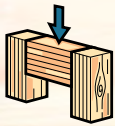

ETA-15/0667 2019

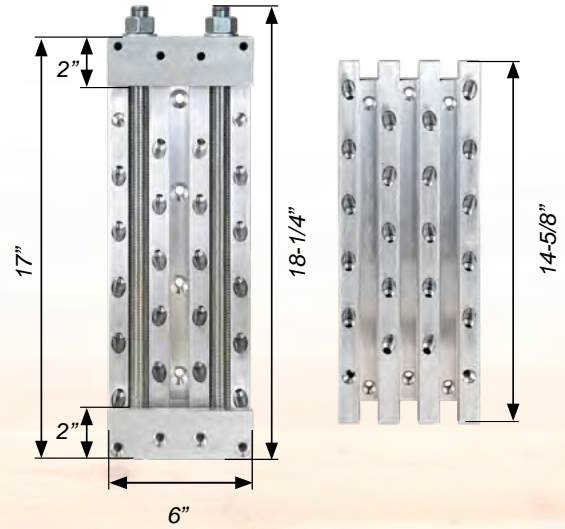

Table 3.16 Allowable Loads for MEGANT 430 x 150

Item	Min. Beam Section	Specific Gravity [G]	Fasteners		Threaded Rod	Allowable Down Load [lb]
			Type	Qty.		
MEGANT 430x150	7-1/2" x 20-1/2"	0.42 [SPF]	VG CSK 5/16" x 6-1/4"	64	2 pcs of M20 x 460 [18-1/4"] Grade 8.8	20,020
		≥ 0.50	VG CSK 5/16" x 6-1/4"	64	2 pcs of M20 x 460 [18-1/4"] Grade 8.8	22,670

Notes:

1. Connection design must meet all relevant requirements of the General Notes to the Designer section.
2. Screw installation must follow the patterns presented in the Installation and Tolerances section.

Table 3.17 Minimum and Maximum Distances (a_{main} , a_{sec})

Beam Depth	a_{max}
20-1/2"	2-3/8"
22-9/16"	2-7/16"
22-1/2"	4-3/8"
24"	5-1/8"
25-1/2"	5-5/8"
27"	6"
28-1/2"	6-1/2"
30"	6-7/8"
31-1/2"	7-3/8"
33"	7-3/4"

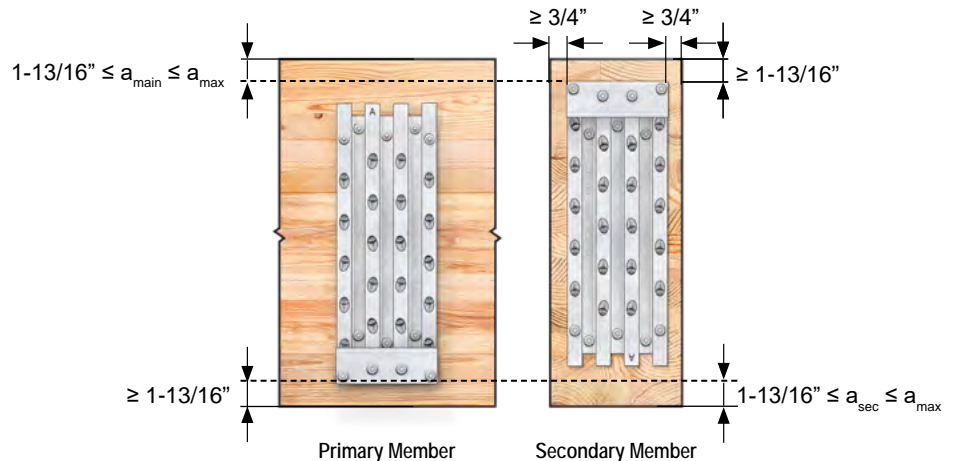

1. Maximum distances do not apply to primary post/column members (a_{main}), where the wood grain direction is parallel to the line of the force.
2. The Design Engineer may interpolate or extrapolate maximum values for a_{main} and a_{sec} for beam sizes not listed in the table.

MEGANT 550 x 150

Connector Parameters and Dimensions

Compatible Materials



Installation Possibilities

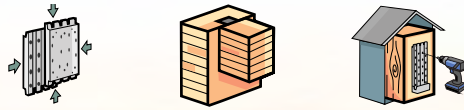

Testing & Certification

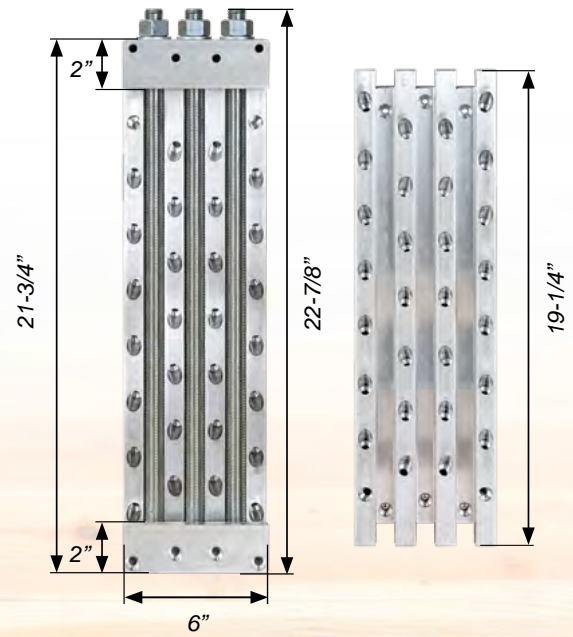
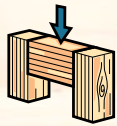

Table 3.18 Allowable Loads for MEGANT 550 x 150

Item	Min. Beam Section	Specific Gravity [G]	Fasteners		Threaded Rod	Allowable Down Load [lb]
			Type	Qty.		
MEGANT 550x150	7-1/2" x 25-1/4"	0.42 [SPF]	VG CSK 5/16" x 6-1/4"	80	3 pcs of M20 x 580 [22-7/8"] Grade 8.8	28,030
		≥ 0.50	VG CSK 5/16" x 6-1/4"	80	3 pcs of M20 x 580 [22-7/8"] Grade 8.8	31,730

Notes:

1. Connection design must meet all relevant requirements of the General Notes to the Designer section.
2. Screw installation must follow the patterns presented in the Installation and Tolerances section.

Table 3.19 Minimum and Maximum Distances (a_{main} , a_{sec})

Beam Depth	a_{max}
25-1/4"	2-3/8"
25-5/16"	2-7/16"
27"	4-1/8"
28-1/2"	5-5/8"
30"	6-7/8"
31-1/2"	7-3/8"
33"	7-3/4"
34-1/2"	8-1/4"
36"	8-3/4"
37-1/2"	9-1/4"

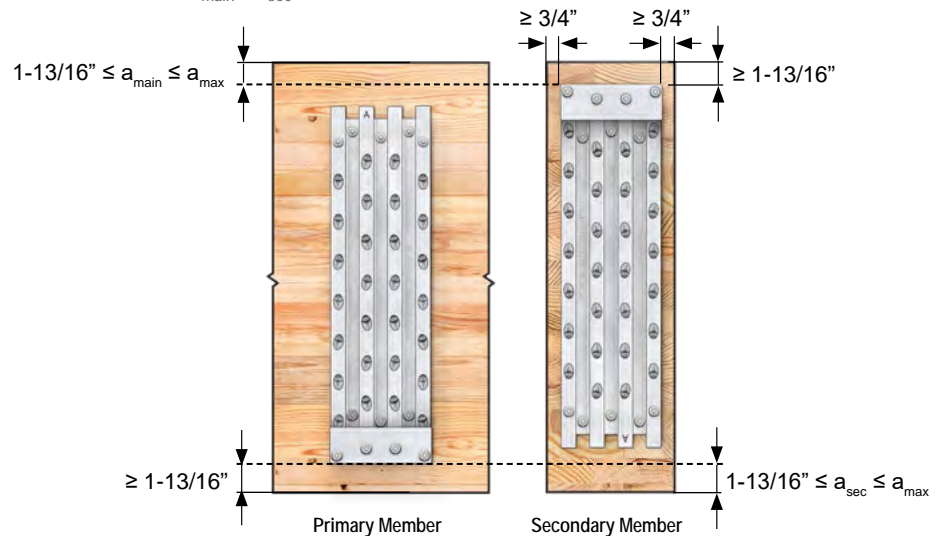

1. Maximum distances do not apply to primary post/column members (a_{main}), where the wood grain direction is parallel to the line of the force.
2. The Design Engineer may interpolate or extrapolate maximum values for a_{main} and a_{sec} for beam sizes not listed in the table.

MEGANT 730 x 150

Connector Parameters and Dimensions

Compatible Materials



Installation Possibilities

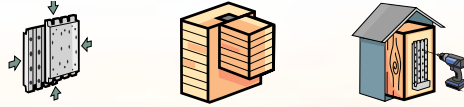

Testing & Certification

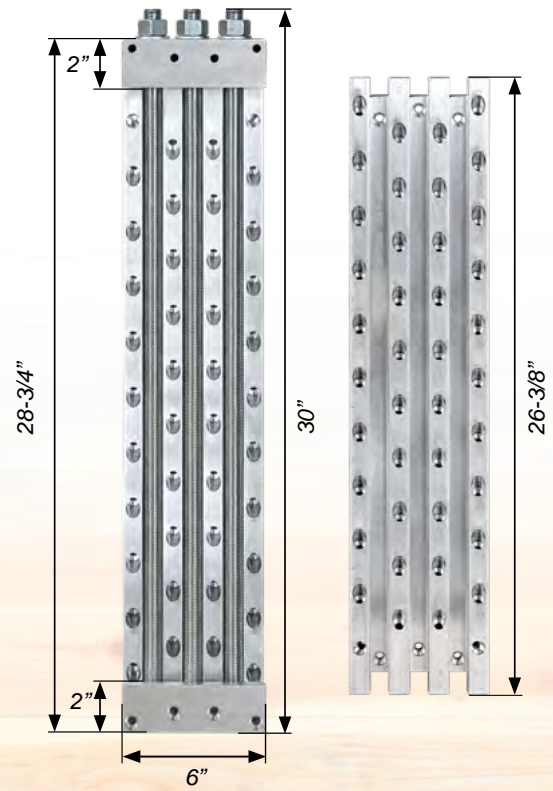
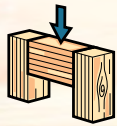

Table 3.20 Allowable Loads for MEGANT 730 x 150

Item	Min. Beam Section	Specific Gravity [G]	Fasteners		Threaded Rod	Allowable Down Load [lb]
			Type	Qty.		
MEGANT 730 x 150	7-1/2" x 33-1/8"	0.42 [SPF]	VG CSK 5/16" x 6-1/4"	104	3 pcs of M20 x 760 [30"] Grade 8.8	32,630
		≥ 0.50	VG CSK 5/16" x 6-1/4"	104	3 pcs of M20 x 760 [30"] Grade 8.8	32,630

Notes:

1. Connection design must meet all relevant requirements of the General Notes to the Designer section.
2. Screw installation must follow the patterns presented in the Installation and Tolerances section.

Table 3.21 Minimum and Maximum Distances (a_{main} , a_{sec})

Beam Depth	a_{max}
33-1/8"	3- 1/4"
34-1/2"	4- 1/2"
36"	6"
37-1/2"	7- 1/2"
38-7/8"	9"
40-3/8"	10-1/8"
41-7/8"	10-1/2"
43-3/8"	11"
44-7/8"	11-3/8"
46-3/8"	11-7/8"

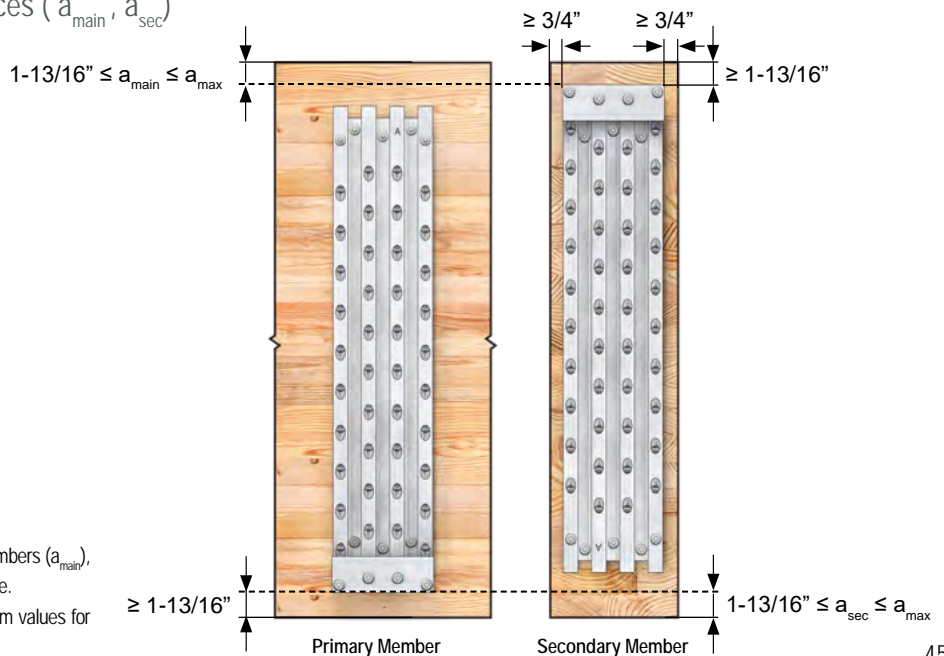

1. Maximum distances do not apply to primary post/column members (a_{main}), where the wood grain direction is parallel to the line of the force.
2. The Design Engineer may interpolate or extrapolate maximum values for a_{main} and a_{sec} for beam sizes not listed in the table.

Installation and Tolerances

Location Instructions - Connector Plates and Screws

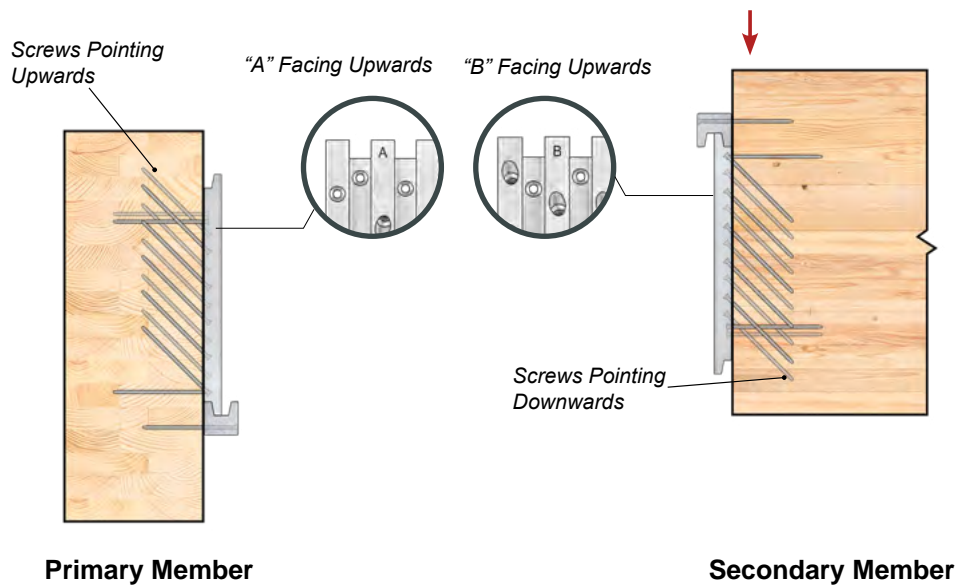

Installation Procedure



The MEGANT connector plates must be installed first. Hold the plate in place according to routing dimensions provided in the tables on the following pages and use a drill to attach it to the wood member using the positioning screws. For accuracy, positioning screws can be installed into pre-drilled pilot holes with a 3/16" mm diameter and a 2" depth.

After the positioning screws, install the perpendicular screws first, followed by the 45° inclined screws using a low RPM and high torque drill. A predrill jig must be used for drilling 45° inclined holes as the countersunk screw head housing in the plates only accommodates minimal tolerance.

The clamping jaws will be installed after the successful installation of all plate screws. The clamping jaw with female threads shall be installed opposite to the threaded rod, washer, and nut assembly.

MEGANT 60 Series



MEGANT
310 x 60

MEGANT
430 x 60

MEGANT
550 x 60

Fastener Orientation

- 90°, Horizontal (Positioning Screws)
- 90°, Horizontal
- 45°, Inclined

MEGANT 100 Series

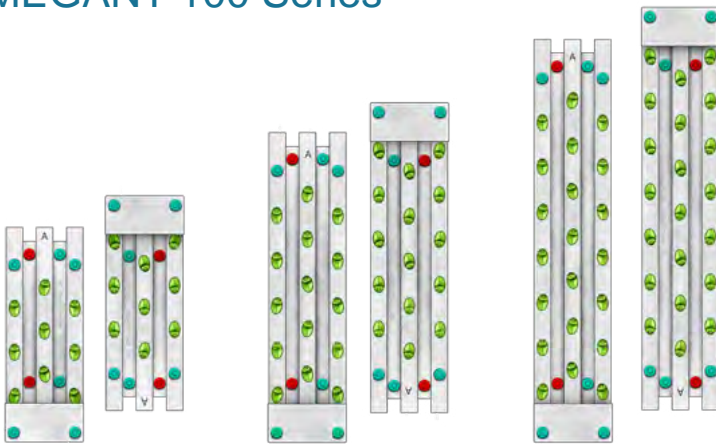

MEGANT
310 x 100

MEGANT
430 x 100

MEGANT
550 x 100

MEGANT 150 Series

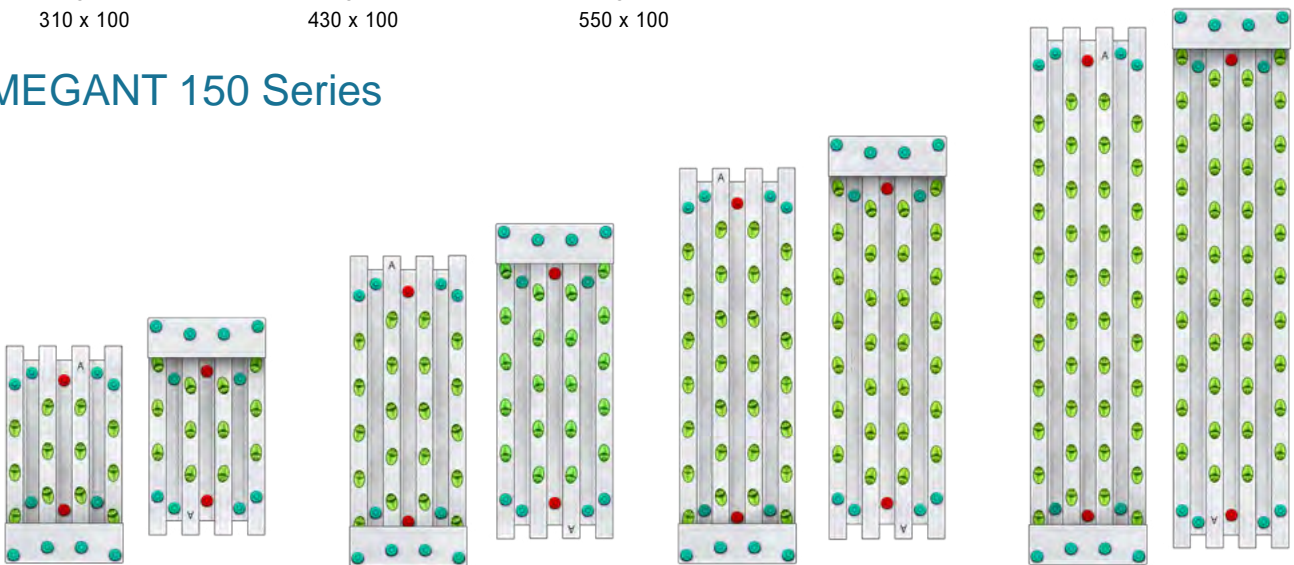

MEGANT
310 x 100

MEGANT
430 x 100

MEGANT
550 x 100

MEGANT
730 x 100

Notes:

1. The red markings indicate the positioning screws which should be aligned with the pre-drilled positioning holes on the wood members which are also indicated in red in the following figures.
2. All concealed installations are suggested to be field verified.

Housing Possibilities

Girder Housing

- Most common housing for concealed installation.
- Concealed from below, the rod can be installed from the top or pre-installed into the threaded clamping jaw attached to the primary member.



Joist Through Housing

- Full depth housing in joist.
- Concealed from below with wood plug, the rod can still be installed from the top pre-installed into the threaded bottom clamping jaw.



Joist Bottom Housing

- Joist housing from bottom up
- Concealed from below with wood plug, the rod needs to be installed from bottom up or pre-installed into the threads of the top clamping jaw.



Joist Top Housing

- Joist housing from top down. Concealed from below. No wood plug required.
- Advantageous when installing the beams to existing columns with floor above.
- Threaded rods can be installed from top down or pre-installed into the threaded bottom clamping jaw.

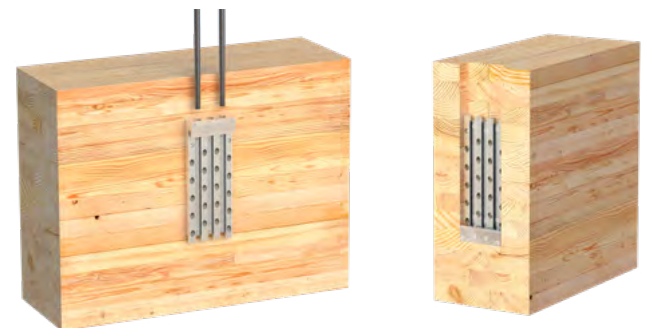

Primary Member

Secondary Member

Routing in Primary Member Only

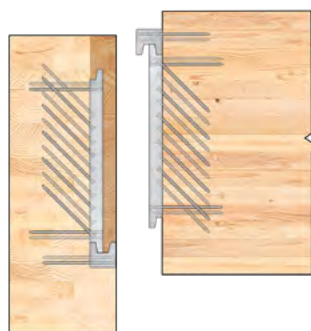

MEGANT Concealed in the Primary Member

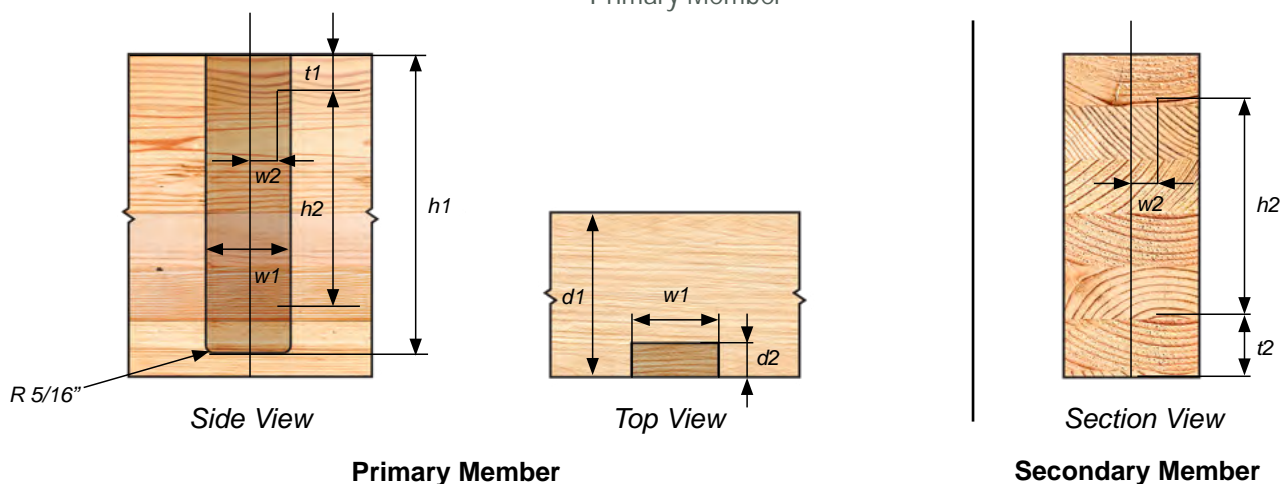

Primary Member

Secondary Member

Table 3.22 Routing in Primary Member - Requirements

Connector	h1	h2	t1	t2	min. d1	min. w1	w2	d2
	in.							
Megant 310 x 60	$a_{main} + 14.252$	6.693	$a_{main} + 2.756$	$a_{sec} + 2.756$	7.953	2.441	0	1.575
Megant 430 x 60	$a_{main} + 18.976$	11.417	$a_{main} + 2.756$	$a_{sec} + 2.756$	7.953	2.441	0	1.575
Megant 550 x 60	$a_{main} + 23.701$	16.142	$a_{main} + 2.756$	$a_{sec} + 2.756$	7.953	2.441	0	1.575
Megant 310 x 100	$a_{main} + 14.252$	6.693	$a_{main} + 2.559$	$a_{sec} + 2.559$	7.953	4.016	0.787	1.575
Megant 430 x 100	$a_{main} + 18.976$	11.417	$a_{main} + 2.559$	$a_{sec} + 2.559$	7.953	4.016	0.787	1.575
Megant 550 x 100	$a_{main} + 23.701$	16.142	$a_{main} + 2.559$	$a_{sec} + 2.559$	7.953	4.016	0.787	1.575
Megant 310 x 150	$a_{main} + 14.252$	6.693	$a_{main} + 2.953$	$a_{sec} + 2.953$	8.346	5.984	0	1.969
Megant 430 x 150	$a_{main} + 18.976$	11.417	$a_{main} + 2.953$	$a_{sec} + 2.953$	8.346	5.984	0	1.969
Megant 550 x 150	$a_{main} + 23.701$	16.142	$a_{main} + 2.953$	$a_{sec} + 2.953$	8.346	5.984	0	1.969
Megant 730 x 150	$a_{main} + 30.787$	23.228	$a_{main} + 2.953$	$a_{sec} + 2.953$	8.346	5.984	0	1.969

- a_{main} refers to the top edge distance in the Primary Member where reinforcement is not required.
- a_{sec} refers to the bottom edge distance in the Secondary Member where reinforcement is not required.
- Tabulated h1 measurement takes into consideration an additional 0.866" below the clamping jaw and an additional 1.181" for the nut assembly at the top of the connector to allow for proper installation.
- Tabulated values for h1 and w1 have been oversized by 1/32".
- Tabulated d1 values include an additional 3/8" between tip of the screw and beam edge to avoid screw blow out.
- Please refer to the Geometry Requirement tables for each respective Beam Hanger System.
- To ensure proper routing for the MEGANT connector, please refer to the Housing Consideration section
- Red markings denote the locations of the positioning screw holes in the MEGANT plate which are to be the first two screws installed.

Routing in Secondary Member Only

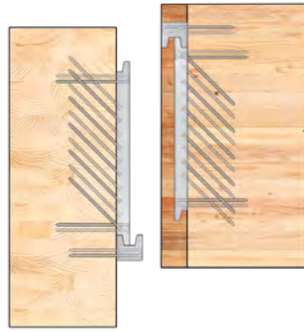

MEGANT Concealed in the Secondary Member

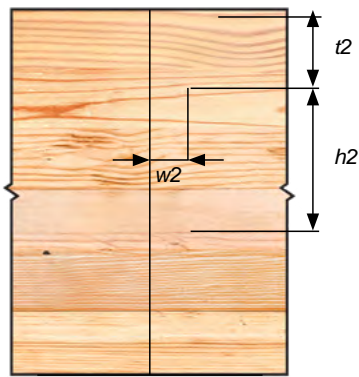

Side View

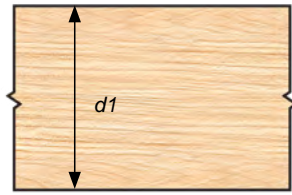

Top View

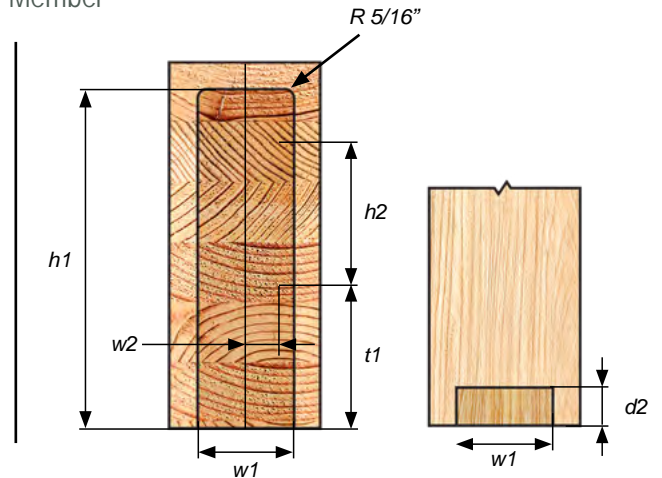

Section View

Bottom View

Primary Member

Secondary Member

Table 3.23 Routing in Secondary Member - Requirements

Connector	h1	h2	t1	t2	min. d1	min. w1	w2	d2
	in.							
Megant 310 x 60	$a_{sec} + 14.252$	6.693	$a_{sec} + 2.756$	$a_{main} + 2.756$	6.378	2.441	0	1.575
Megant 430 x 60	$a_{sec} + 18.976$	11.417	$a_{sec} + 2.756$	$a_{main} + 2.756$	6.378	2.441	0	1.575
Megant 550 x 60	$a_{sec} + 23.701$	16.142	$a_{sec} + 2.756$	$a_{main} + 2.756$	6.378	2.441	0	1.575
Megant 310 x 100	$a_{sec} + 14.252$	6.693	$a_{sec} + 2.559$	$a_{main} + 2.559$	6.378	4.016	0.787	1.575
Megant 430 x 100	$a_{sec} + 18.976$	11.417	$a_{sec} + 2.559$	$a_{main} + 2.559$	6.378	4.016	0.787	1.575
Megant 550 x 100	$a_{sec} + 23.701$	16.142	$a_{sec} + 2.559$	$a_{main} + 2.559$	6.378	4.016	0.787	1.575
Megant 310 x 150	$a_{sec} + 14.252$	6.693	$a_{sec} + 2.953$	$a_{main} + 2.953$	6.378	5.984	0	1.969
Megant 430 x 150	$a_{sec} + 18.976$	11.417	$a_{sec} + 2.953$	$a_{main} + 2.953$	6.378	5.984	0	1.969
Megant 550 x 150	$a_{sec} + 23.701$	16.142	$a_{sec} + 2.953$	$a_{main} + 2.953$	6.378	5.984	0	1.969
Megant 730 x 150	$a_{sec} + 30.787$	23.228	$a_{sec} + 2.953$	$a_{main} + 2.953$	6.378	5.984	0	1.969

Notes:

- a_{main} refers to the top edge distance in the Primary Member where reinforcement is not required.
- a_{sec} refers to the bottom edge distance in the Secondary Member where reinforcement is not required.
- Tabulated h1 measurement takes into consideration an additional 0.866" below the clamping jaw and an additional 1.181" for the nut assembly at the top of the connector to allow for proper installation.
- Tabulated values for h1 and w1 have been oversized by 1/32".
- Tabulated d1 values include an additional 3/8" between tip of the screw and beam edge to avoid screw blow out.
- Tabulated h1 values depend on the type of housing selected (see Housing possibilities page 48).
- To ensure a proper routing for the MEGANT connector, please refer to the Housing Consideration section
- Indicator dots reference the locations of the screw holes in the MEGANT plate which are to be the first two screws installed as positioning screws.
- Please refer to the Geometry Requirement tables for each respective Beam Hanger System.

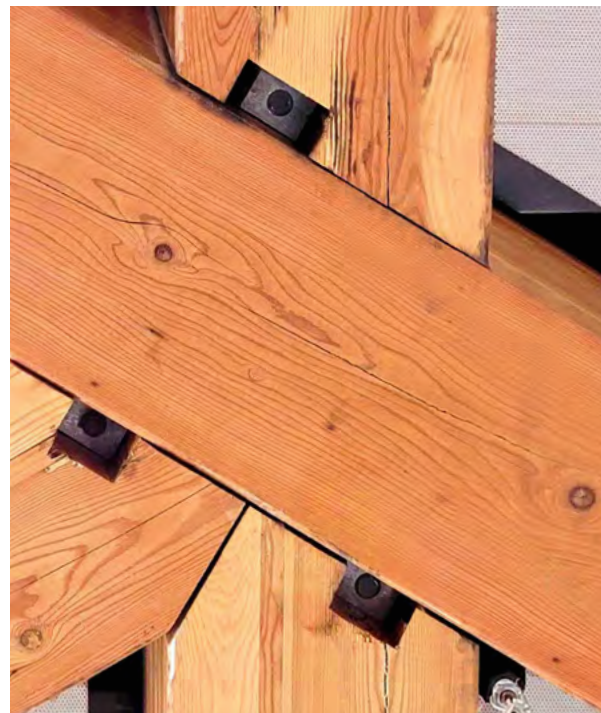
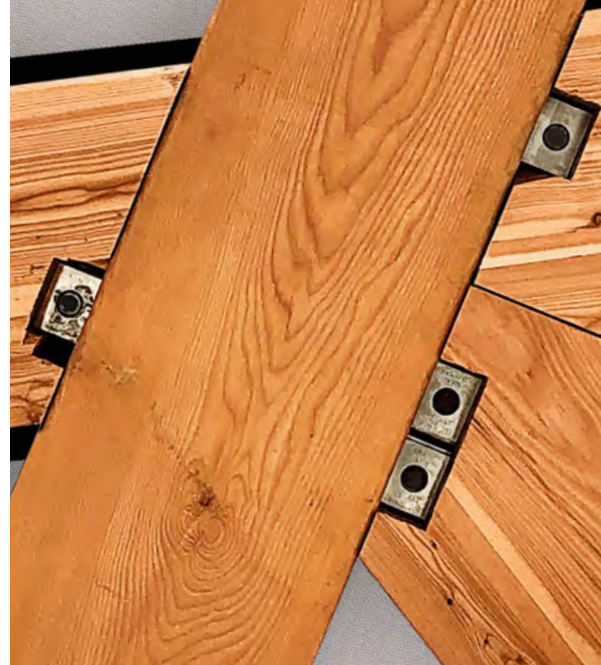

Clayton Community Centre

Calgary, Alberta

The image shows a close-up, low-angle view of a ceiling. The ceiling is constructed from light-colored wood planks, likely pine or spruce, arranged in a grid pattern. The planks are separated by dark, corrugated metal panels, which appear to be made of galvanized steel. The lighting is warm and even, highlighting the natural grain of the wood and the metallic texture of the panels. The perspective is from below, looking up at the ceiling structure.

Rocky Ridge YMCA

Calgary, Alberta

Appendix

APPENDIX A: FIRE DESIGN	54
Full Scale Loaded Fire Test	54
Char Layer Design	54
The Corner Effect	55
Additional Fire Design Considerations for MEGANT Connectors	55
APPENDIX B: UPLIFT RESISTANCE DESIGN	56
Fully-Threaded Toe Screws	56
APPENDIX C: RICON S VS REINFORCEMENT	57
Primary Member Details	57
Secondary Member Details	58
Reinforcement Tables	58
Reinforcement Design Examples	60
Reinforcement Possibilities	60
Installation of Reinforcement	61
APPENDIX D: SKEWED & SLOPED CONNECTIONS	62
APPENDIX E: DETAILING SECTION	64
GIGANT	64
RICON S VS	64
MEGANT	66

Appendix A: Fire Design

Full Scale Loaded Fire Test



The NDS and the CSA recognize wood as a combustible material and a poor conductor of heat, and refer to the property of wood in developing an insulating char layer during a fire.

Wood can protect non-combustible elements such as a Beam Hanger System through an appropriately designed wood cover. The American Wood Council Technical Report (TR 10) provides guidelines on char layer design for Beam Hangers in fire scenarios.

Full scale fire resistance rating testing with fully loaded specimens at the **Southwest Research Institute in San Antonio Texas** confirmed the TR 10 char layer calculations and awarded the RICON S VS and MEGANT Beam Hanger Systems with a 1.5h fire rating.

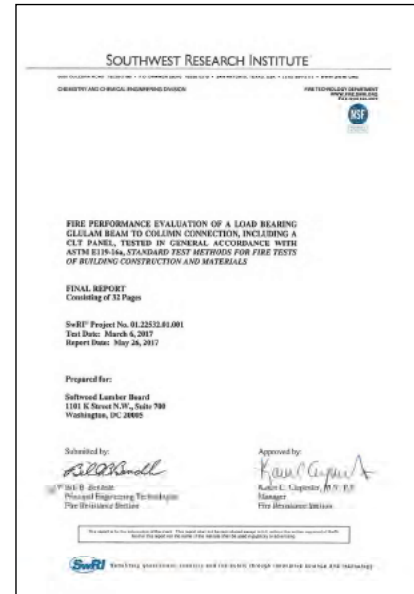

Glulam Connection Fire Resistance Rating

Char Layer Design

Table A.1 Char Layer and Required Wood Cover for Fire-Resistance Rating Per TR 10-2021

Required Fire Resistance	Char Depth a_{char}	Wood Cover	
		Bonded Gap	Unbonded Gap
Hours	in.	in.	in.
1	1.5"	1.71"	3.0"
2	2.6"	3.01"	5.2"
3	3.6"	3.17"	7.3"

Note:

- a_{char} is provided per table 4.1.1.4A of the TR 10-2021.
- Bonded gap: protected beam end or gap using fire-stopping materials to prevent charring (fire caulking, intumescent tape, glued wood, etc.) per clause 4.4.1.5 and 4.5.3 of TR 10-2021.
- Unbonded gap: char contraction at wood member ends and edges results in ignition of wood surfaces that extend into the gaps at these locations. The penetration of ignition into these unbonded (unprotected) gaps is assumed to be twice the char depth, $2a_{char}$, per clause 4.5.2 of TR 10-2021.
- Wood cover is calculated according to clause 4.4.1.3 of TR 10-2021, assuming there is a single layer of wood as protection to the connectors

The Corner Effect

A multi directional exposure of columns and beams to the fire will result in faster charring at the corners. To account for this effect, corner rounding needs to be considered in fire design.

The radius of the corner r , is equal to the estimated char layer thickness.



Additional Fire Design Consideration for MEGANT Connectors

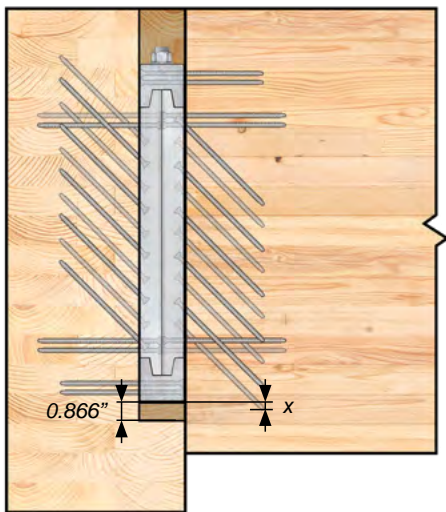

Side View

Inclined screw embedment at the bottom of the connector assembly must be considered for char layer design. The vertical distance, x between the screw tip and the bottom of the clamping jaw as indicated in the figure above is:

- 1-9/16" [40 mm] for MEGANT 60 series
- 3/8" [10 mm] for MEGANT 100 & 150 series.

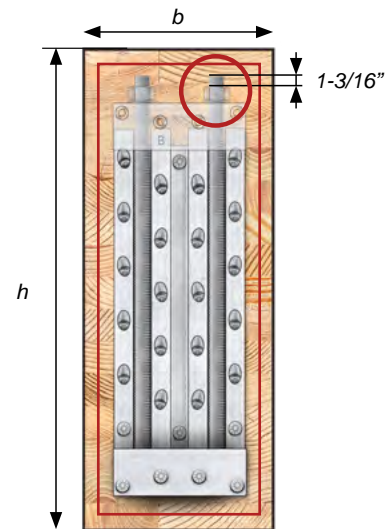

Section View

The threaded rod assembly must be taken into account when determining the placement of the connector in the beam section and evaluating its fire resistance rating. The threaded rods extend 1-3/16" [30mm] above the edge of the clamping jaw in all MEGANT connectors.

Appendix B: Uplift Resistance Design

When using a Beam Hanger System, additional hardware may be required to resist potential uplift forces applied to the connection. Beam Hanger Systems can resist uplift loading scenarios through the application of a fully threaded toe screw.

Fully-Threaded Toe Screws

Fully threaded toe screws are installed after the connectors are dropped in place. The orientation of the screw relative to the sliding direction of the joint assures that the screw resists primarily in tension.

Fully-threaded toe screws can be used with all Beam Hanger Systems, the GIGANT, RICON S VS and the MEGANT.

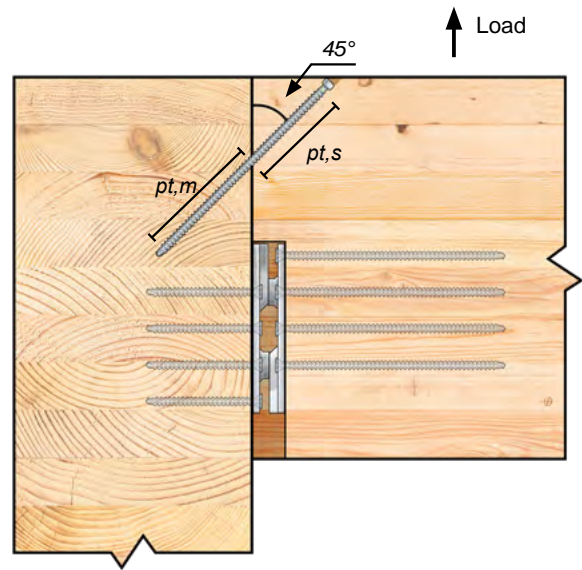

Example of Toe Screw Installation

Table B.1. Allowable Loads [lb] per Fastener with Minimum Effective Thread Penetration Length of the Primary $p_{t,m}$ and the Secondary Member $p_{t,s}$. Fastener Installed at 45°

Type	D		Relative Density [G]	Thread Penetration Length $p_{t,m}$ $p_{t,s}$ [in]						
	in.	[mm]		3"	4"	5"	6"	7"	8"	9"
ASSY VG Cyl	5/16"	[8]	0.42 (SPF)	617	822	1028	1233	1255	1255	1255
	3/8"	[10]		689	919	1149	1379	1609	1803	1803
	5/16"	[8]	0.49 (D.Fir)	721	962	1202	1255	1255	1255	1255
	3/8"	[10]		814	1086	1357	1629	1803	1803	1803

Notes:

1. Capacities listed in this table assume short term loading factor $C_D = 1.6$
2. A minimum of two toe screws is recommended. = Tensile Strength of fastener governs.

Appendix C: RICON S VS Reinforcement

Where physical requirements dictate connector placements other than the one specified in this document, connection strength may be reduced, and reinforcement is required. Reinforcement may be achieved through the use of fully threaded fasteners which are listed in ICC ESR-3178.

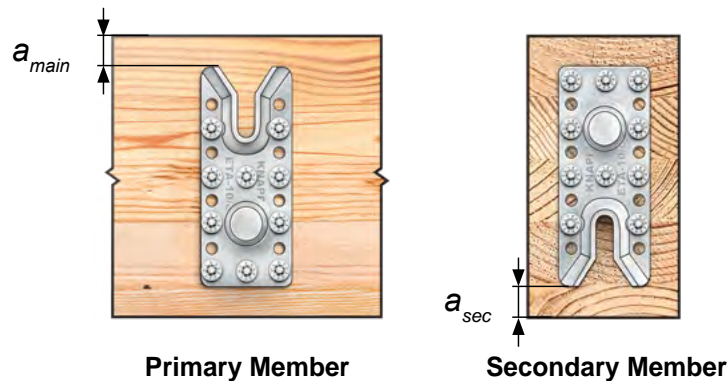

Primary Member Details

The effective thread penetration length $p_{t,1}$ and $p_{t,2}$ above and below the upper most fastener in the primary member [UMFPM] must exceed the value p_t provided in tables C.1 through C.5.

The fully threaded reinforcing screw must penetrate sufficiently ($> 4D$) into the upper most section of the primary member ($0.3d_{PM}$).

The effective thread penetration length may be adjusted to accommodate a wooden plug covering the screw head or to optimize screw selection to available screw lengths.

The adjustment must fulfill the requirement that $\min(p_{t,1}, p_{t,2}) > p_t$. The reinforcing fully threaded wood screw in the primary member may be installed from the top down or the bottom up, as required.

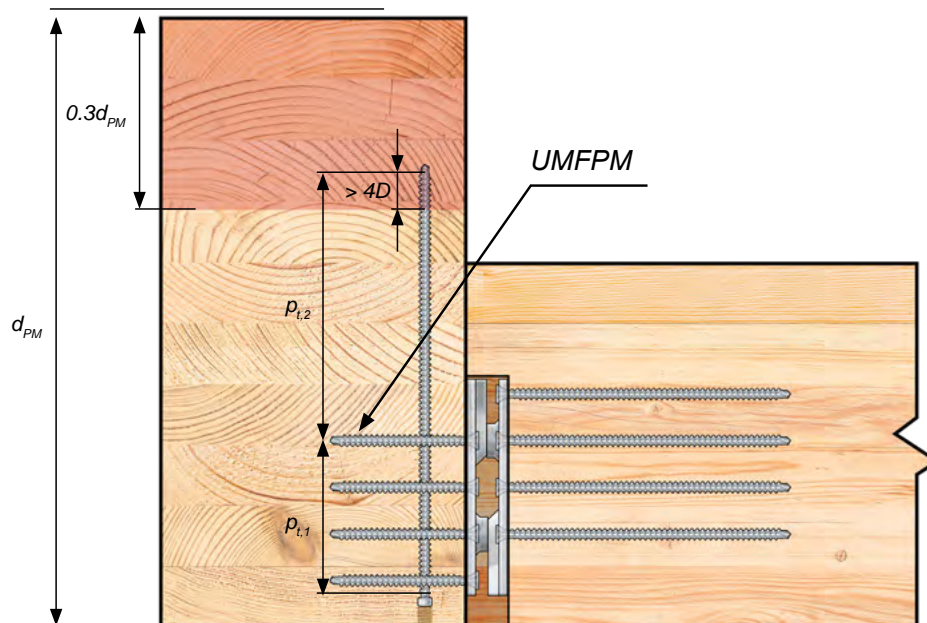

Secondary Member Details

The effective thread penetration length $p_{t,1}$ and $p_{t,2}$ above and below the lower most fastener in the secondary member [LMFSM] must exceed the value p_t provided in tables C.1 through C.5.

The fully threaded reinforcing screw must sufficiently penetrate ($> 4D$) into the lower most section of the secondary member ($0.3d_{SM}$).

The effective thread penetration length may be adjusted to accommodate a wooden plug covering the screw head or to optimize to available screw lengths.

The adjustment must fulfill $\min(p_{t,1}, p_{t,2}) > p_t$. The reinforcing fully threaded wood screw in the secondary member may be installed from the top down or the bottom up, as required.

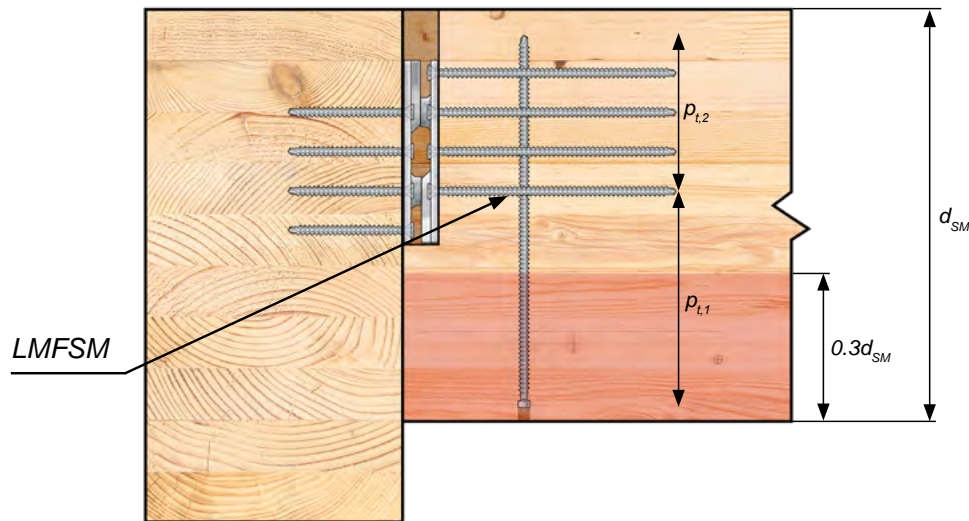

Reinforcement Tables

The appropriate thread penetration length (p_t) provided in tables C.1 through C.5 is a function of the h_i/d_i ratio, where h_i is the distance between the

UMFPM and the top of the primary member, or the distance between the LMFSM and the bottom of the secondary member.

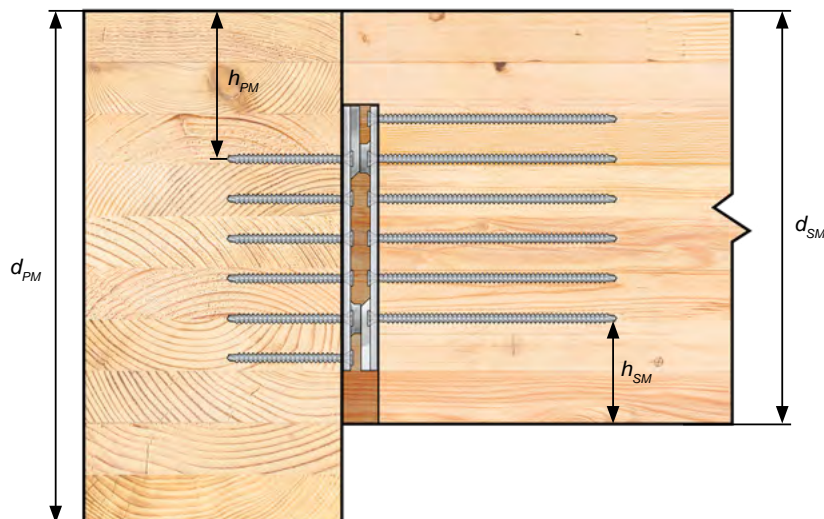

Table C.1 Minimum Thread Penetration p_t [in] Required for RICON S VS 140x60

h_i/d_i	0_0	0_1	0_2	0_3	0_4	0_5	0_6	0_7	0_8	0_9
0.3_	3.4	3.6	3.8	4.1	4.3	4.5	4.7	4.9	5.1	5.4
0.4_	5.6	5.8	6.1	6.3	6.5	6.8	7	7.2	7.5	7.7
0.5_	7.9	8.2	8.4	8.7	8.9	9.1	9.4	9.6	9.8	10.1

Table C.2 Minimum Thread Penetration p_t [in] Required for RICON S VS 200x60

h_i/d_i	0_0	0_1	0_2	0_3	0_4	0_5	0_6	0_7	0_8	0_9
0.3_	4.9	5.2	5.5	5.8	6.1	6.4	6.7	7	7.3	7.6
0.4_	8	8.3	8.6	9	9.3	9.6	10	10.3	10.6	11
0.5_	11.3	11.7	12	12.3	12.7	13	13.3	13.7	14	14.3

Table C.3 Minimum Thread Penetration p_t [in] Required for RICON S VS 200x80

h_i/d_i	0_0	0_1	0_2	0_3	0_4	0_5	0_6	0_7	0_8	0_9
0.3_	6.3	6.6	7	7.4	7.8	8.2	8.6	9	9.4	9.8
0.4_	10.2	10.7	11.1	11.5	11.9	12.4	12.8	13.2	13.7	14.1
0.5_	14.5	15	15.4	15.8	16.3	16.7	17.1	17.6	18	18.4

Table C.4 Minimum Total Thread Penetration p_t [in] Required for RICON S VS 290x80

h_i/d_i	0_0	0_1	0_2	0_3	0_4	0_5	0_6	0_7	0_8	0_9
0.3_	7.6	8	8.5	9	9.4	9.9	10.4	10.9	11.4	11.9
0.4_	12.4	12.9	13.4	13.9	14.4	15	15.5	16	16.5	17.1
0.5_	17.6	18.1	18.7	19.2	19.7	20.2	20.7	21.3	21.8	22.3

Table C.5 Minimum Thread Penetration p_t [in] Required for RICON S VS XL 390x80

h_i/d_i	0_0	0_1	0_2	0_3	0_4	0_5	0_6	0_7	0_8	0_9
0.3_	14.1	15	15.8	16.7	17.5	18.4	19.3	20.2	21.2	22.1
0.4_	23	24	24.9	25.9	26.8	27.8	28.8	29.8	30.7	31.7
0.5_	32.7	33.7	34.7	35.6	36.6	37.6	38.6	39.5	40.5	41.4

Reinforcement notes:

- Ratios h_i/d_i are applicable to joist and header reinforcement.
- Values in tables C.1 and C.2 are only applicable to 5/16" ASSY VG fasteners and values in tables C.3, C.4 and C.5 are only applicable to 3/8" ASSY VG fasteners.
- A minimum of two reinforcement fasteners shall be used.
- For design purposes p_{t1} & p_{t2} a maximum of 8-3/8" can be used. Beyond this value, the tensile resistance of the fastener governs the failure modes. Longer fasteners may still be used when the length is required for installation purposes.
- Fasteners shall be placed in a symmetrical pattern respecting all governing spacing requirements.
- Double connections may require additional reinforcement.
- RICON S VS XL 390x80 reinforcement with more than 2 screws must be designed by a design professional.

Reinforcement Design Example

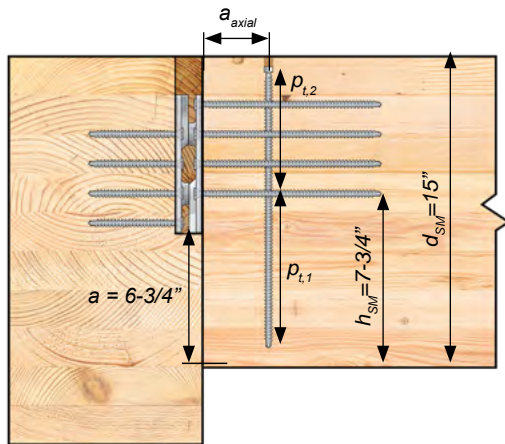

Side View

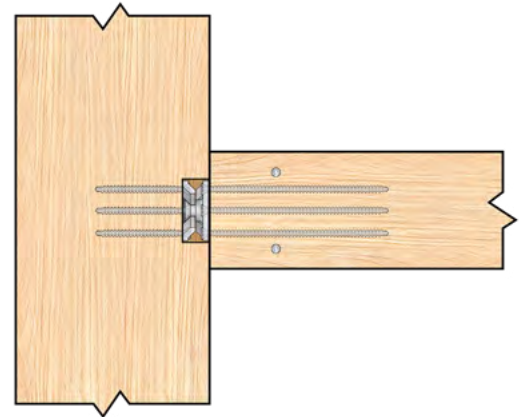

Top View

A 4-3/4" x 15" Glulam beam is connected to a girder with the 140x60 RICON S VS mounted high in the cross section. Reinforcement is required since $a_{max} = 3"$ for a 15" beam, and the $a = 6-3/16"$.

With a design dimension of $h_{SM} = 7-3/4"$ the h_i/d_i ratio equals:

- $7-3/4" / 15" = 0.52$

According to Table C.1, for an h_i/d_i ratio of 0.52, $p_t = 8.42"$. Therefore $p_{t,1}$ and $p_{t,2}$ have to be greater than or equal to 8.42".

With 2 VG Cyl 5/16" x 11" fasteners countersunk 1" and installed from above, the effective embedment lengths are:

- $p_{t,1} = 2 \times 4-3/4" = 8.42"$
- $p_{t,2} = 2 \times 6-1/4" = 8.42"$

Reinforcement Possibilities

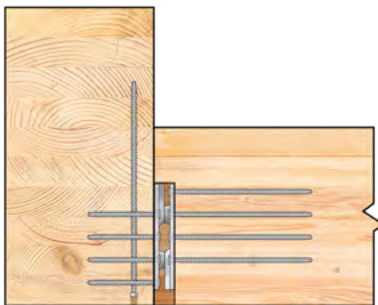

**Header Reinforcement
from Below**

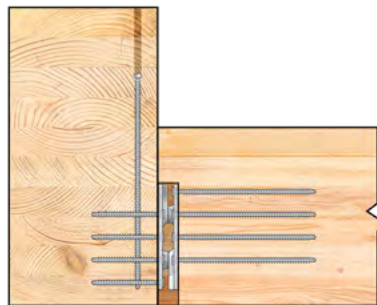

**Header Reinforcement
from Above**

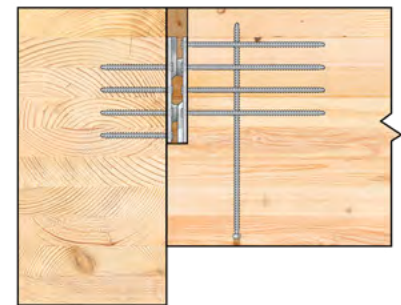

**Joist Reinforcement
from Below**

Installation of Reinforcement

Reinforcing fasteners need to be installed as close as possible to the anticipated peak stress location while adhering to the minimum geometry requirements.

It is not recommended to exceed a_{axial} or e_{axial} provided in Table C.6, and illustrated below. Reinforcement shall be assigned to one row of screws parallel to the line of the joint.

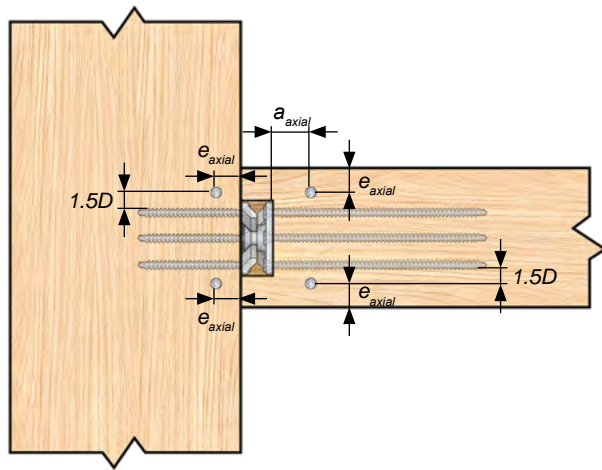

Primary Member

Secondary Member

Top View

Geometry Requirements with 2 Reinforcement Screws in Each Member

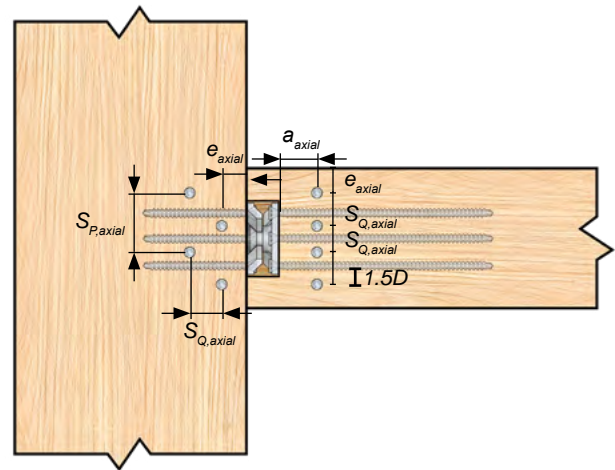

Primary Member

Secondary Member

Top View

Geometry Requirements with > 2 Reinforcement Screws in Each Member

Table C.6 Geometry Requirements without Pre-Drilling

Specific Gravity G	End Distance a_{axial}	Edge Distance e_{axial}	Spacing Between Fasteners in a Row $S_{P,axial}$	Spacing Between Rows $S_{Q,axial}$
G ≤ 0.5	5D	3D	5D	2.5D
G ≥ 0.5	5D	3D	5D	2.5D
D. Fir	7.5D	3D	7.5D	2.5D

Notes:

1. For accurate installation of long reinforcing screws, pre-drilling can be utilized.
2. Pre-drill 5/16" diameter screws with a 3/16" drill bit and 3/8" diameter screws with a 1/4" drill bit.
3. Pre-drilling of full screw length is permitted, if required.

Appendix D: Skewed & Sloped Configurations

The Beam Hanger System relies on different fastener lengths to ensure proper load transfer into the primary and secondary members.

Primary Member

The connector plate installed into the primary member, for either a girder beam or a column, has fasteners driven in the side grain. This fiber orientation promotes higher withdrawal capacity, therefore the fasteners may be shorter and still sustain the same load.

ASSY VG CSK 5/16" x 3-1/8" or longer screws need to be used with:

- RICON S VS 140x60
- RICON S VS 200x60

ASSY VG CSK 3/8" x 4" or longer screws need to be used with:

- RICON S VS 200x80
- RICON S VS 290x80
- RICON S VS XL 390x80

Secondary Member

The connector plate installed into the secondary member has fasteners driven into the end grain. Longer fully threaded screws are used in the secondary member in order to compensate for the withdrawal capacity reduction characteristic of this orientation of the wood fiber.

ASSY VG CSK 5/16" x 6-1/4" or longer screws need to be used with:

- RICON S VS 140x60
- RICON S VS 200x60

ASSY VG CSK 3/8" x 7-7/8" or longer screws need to be used with:

- RICON S VS 200x80
- RICON S VS 290x80
- RICON S VS XL 390x80



Rafter to Ridge Beam Connection



Joist to Beam Connection

In skewed connections, the connector plate installed into the secondary member has fasteners driven into the grain at an angle relative to the connection angle.

The connection benefits from the changing the angle to grain relationship, and thus respective design values may be achieved with shorter screw length in the secondary member.

Sloped and Skewed Connection Requirements

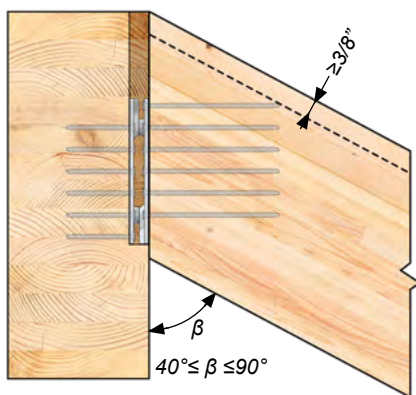

Side View: Rafter to Ridge Beam Connection

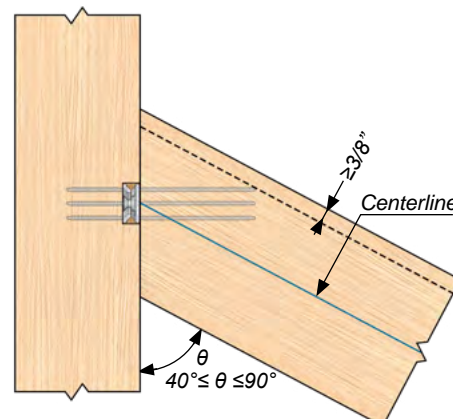

Top View: Joist to Beam or Column Connection

In skewed connections, the connector placement must adhere to the connection geometry requirements in order to be used without reinforcement. Where connection geometry imposes restrictions, fastener length may be reduced, and allowable connection loads shall be adjusted with the appropriate reduction factor (R_{SKEWED}).

For horizontal tilts (θ), the connector must be positioned within the centerline of the joist, otherwise eccentricities and resulting moments must be accounted for by the designer.

Table D.1 Adjustment Factor (R_{SKEWED}) for RICON S VS 140x60 & 200x60

Screw Length [in]	β or $\theta = 90^\circ$	β or $\theta = 80^\circ$	β or $\theta = 70^\circ$	β or $\theta = 60^\circ$	β or $\theta = 50^\circ$	β or $\theta = 40^\circ$
6-1/4"	1.0	1.0	1.0	1.0	1.0	1.0
5-1/2"	0.9	1.0	1.0	1.0	1.0	1.0
4-3/4"	0.8	0.9	0.9	1.0	1.0	1.0

Table D.2 Adjustment Factor (R_{SKEWED}) for RICON S VS 200x80, 290x80 & 390x80

Screw Length [in]	β or $\theta = 90^\circ$	β or $\theta = 80^\circ$	β or $\theta = 70^\circ$	β or $\theta = 60^\circ$	β or $\theta = 50^\circ$	β or $\theta = 40^\circ$
7-7/8"	1.0	1.0	1.0	1.0	1.0	1.0
7-1/8"	0.9	1.0	1.0	1.0	1.0	1.0
6-1/4"	0.8	0.9	0.9	1.0	1.0	1.0
5-1/2"	0.7	0.8	0.8	0.9	0.9	1.0

Notes:

1. Reduced fastener lengths only apply for installation in the secondary member.
2. Allowable Load of the connector must be adjusted with the reduction provided in the table.

Appendix E: Detailing Section

This appendix provides dimension of the different Beam Hangers Systems in this design guide.

GIGANT

GIGANT 120 X 40

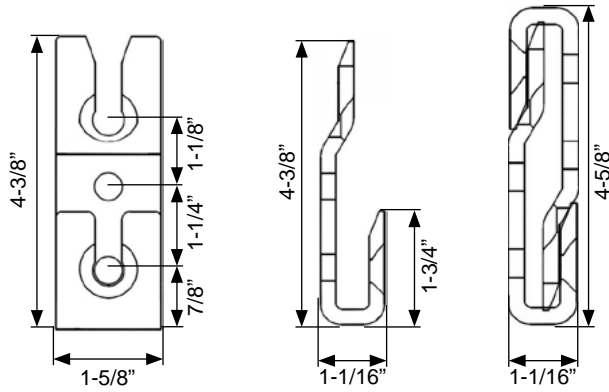

GIGANT 150 X 40

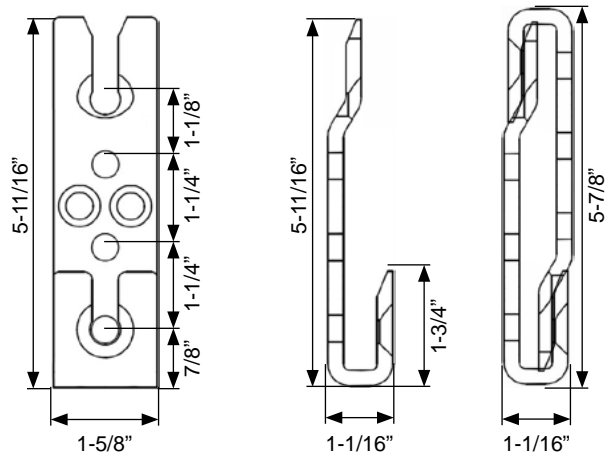

GIGANT 180 X 40

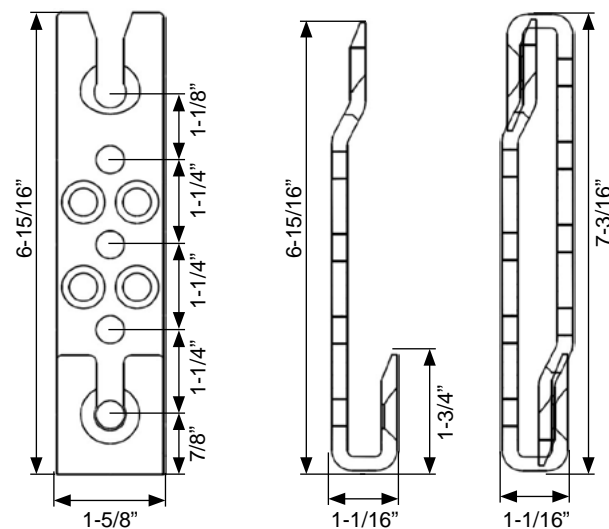

RICON S VS

RICON S VS 140 x 60

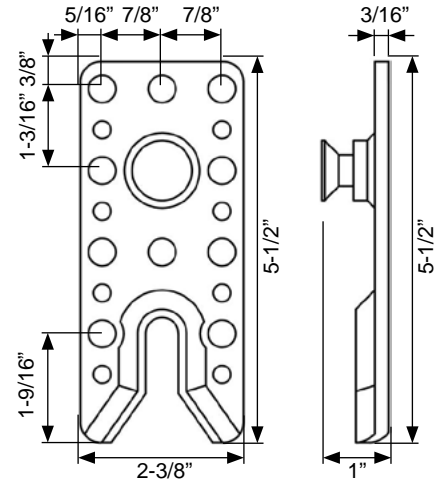

RICON S VS 200 x 60

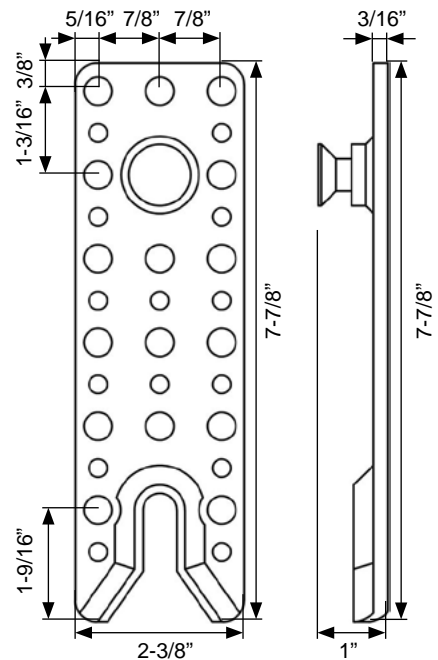

RICON S VS 200 x 80

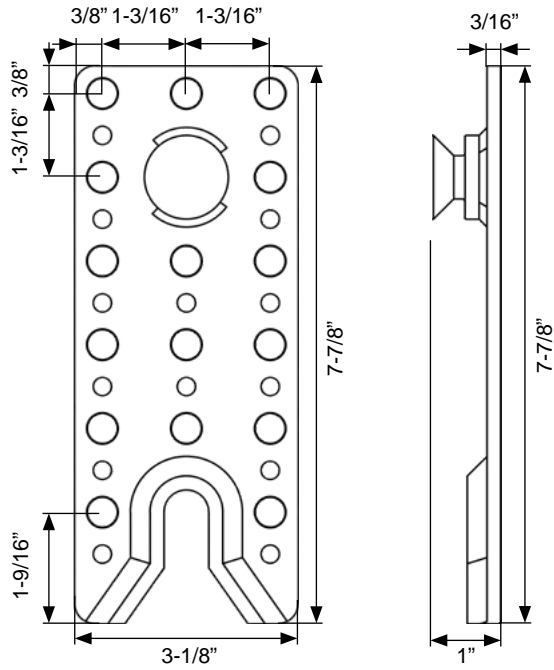

RICON S VS XL - 390 x 80

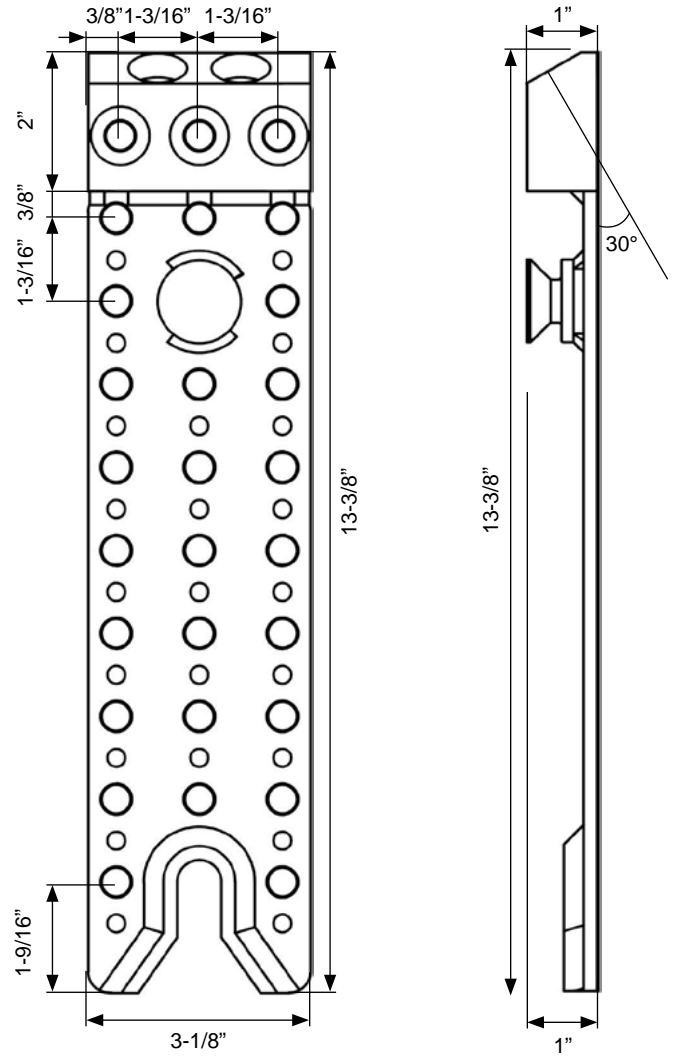

RICON S VS 290 x 80

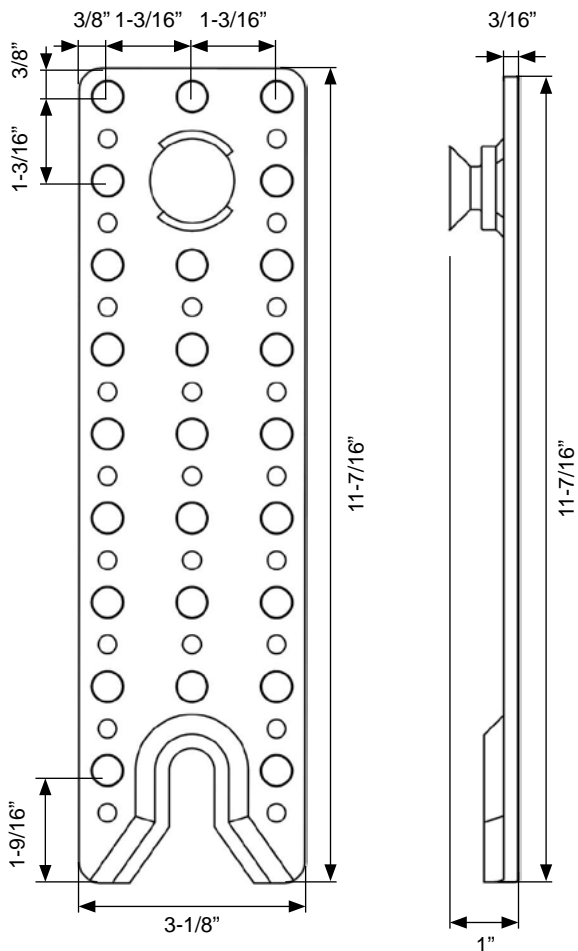

MEGANT

MEGANT 60 SERIES

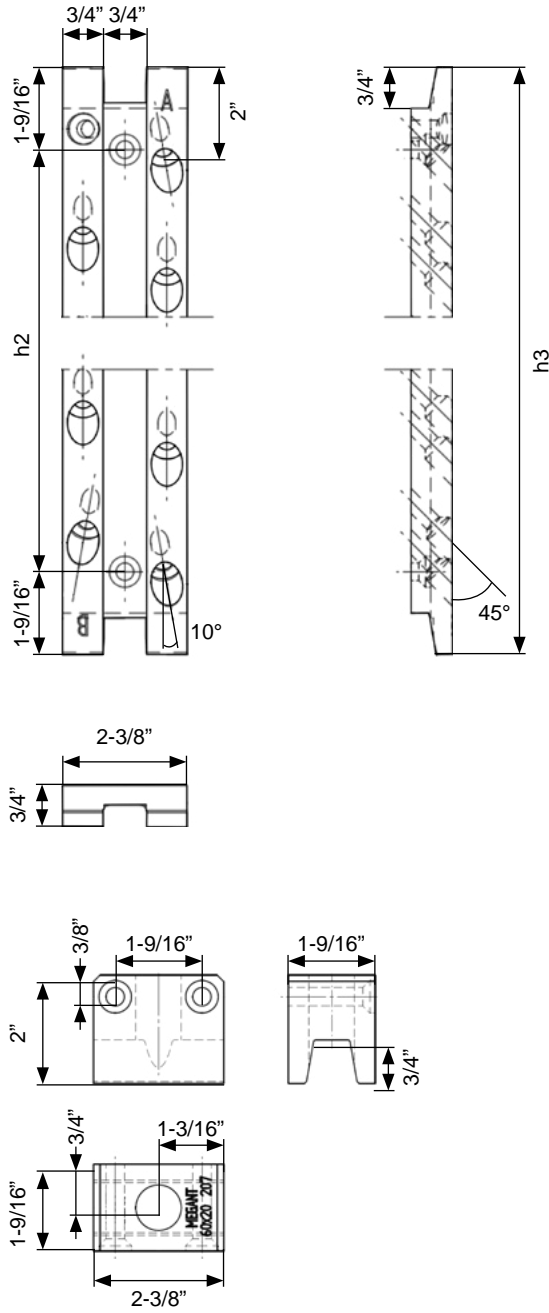

MEGANT 100 SERIES

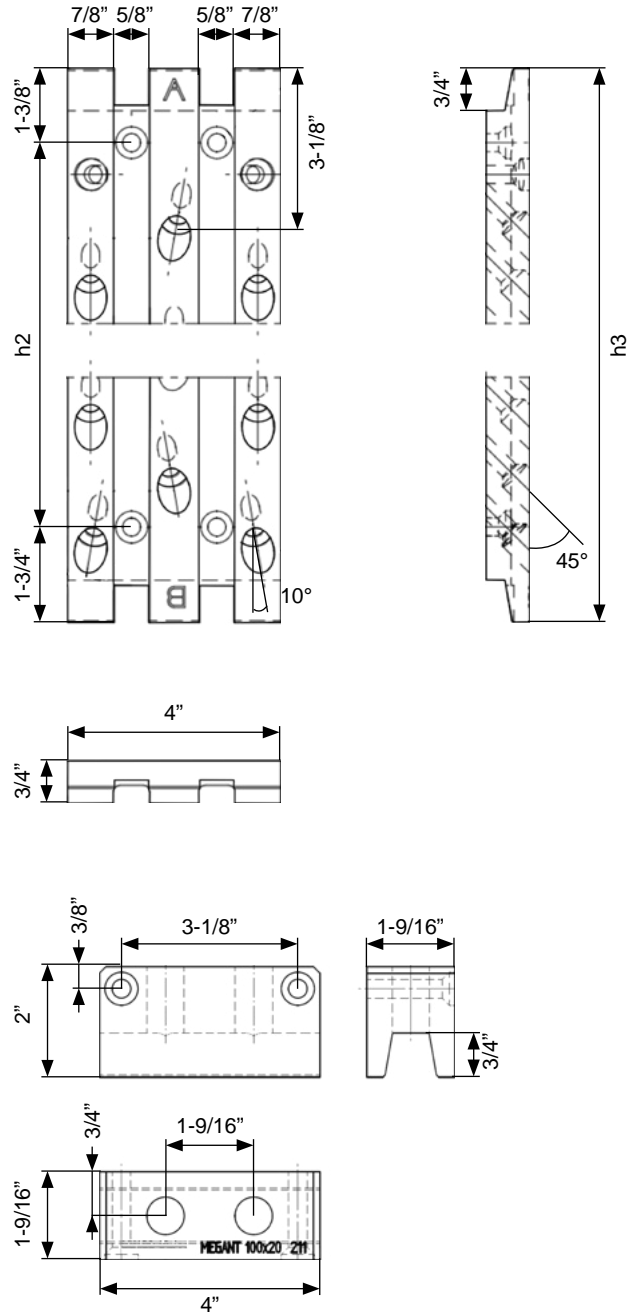

Connector	h2	h3
	in.	
MEGANT 310x60	6-11/16"	9-7/8"
MEGANT 430x60	11-7/16"	14-5/8"
MEGANT 550x60	16-1/8"	19-1/4"

Connector	h2	h3
	in.	
MEGANT 310x100	6-11/16"	9-7/8"
MEGANT 430x100	11-7/16"	14-5/8"
MEGANT 550x100	16-1/8"	19-1/4"

MEGANT 150 SERIES

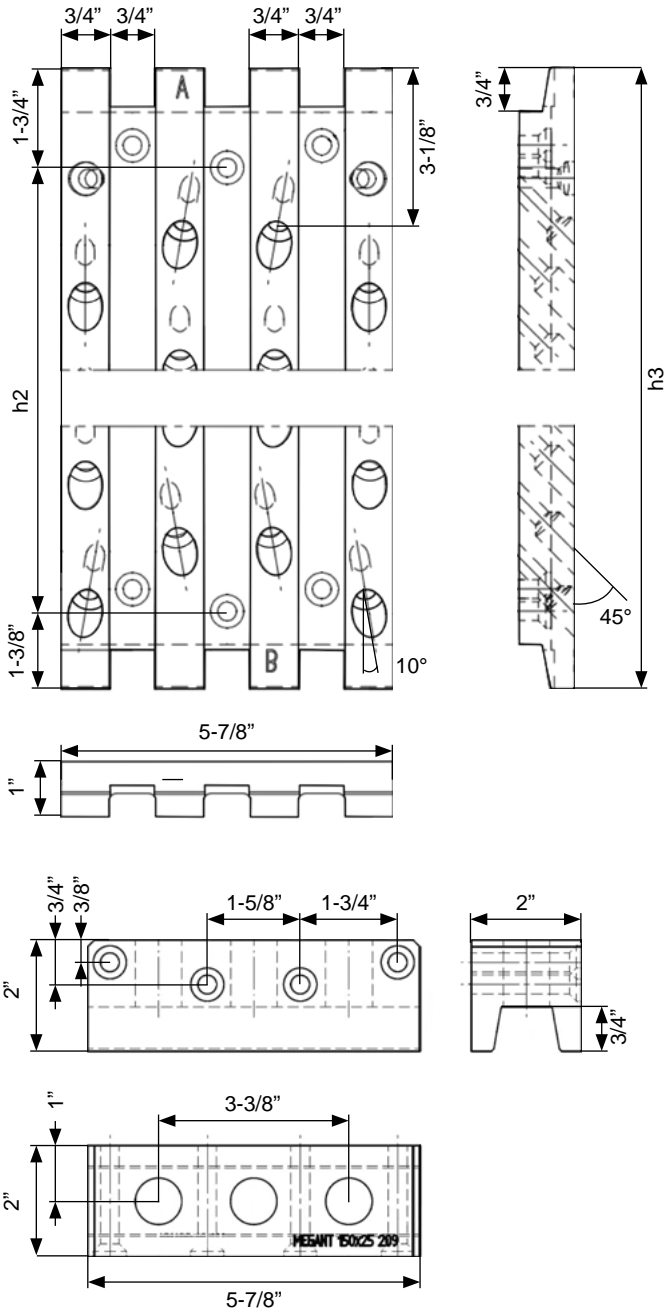

Connector	h2	h3
	in.	
MEGANT 310x100	6-11/16"	9-7/8"
MEGANT 430x100	11-7/16"	14-5/8"
MEGANT 550x100	16-1/8"	19-1/4"
MEGANT 730x150	23-1/4"	26-3/8"

MTC Solutions provide sustainable, high quality mass timber connection solutions to a rapidly evolving and thriving industry. We drive innovation through certified research and development and contribute our part to the education of young talent and experienced professionals in the technology used in sustainable design.





MTTC

SOLUTIONS

info@mtcsolutions.com

1.866.899.4090

mtcsolutions.com

