



# Connectors Design Guide



## **Disclaimer**

The information in this document is provided on an “as is” basis and for general information purposes only. While MTC Solutions aims to keep the information provided in this document complete, accurate, and in line with state-of-the-art design methods, MTC Solutions, its affiliates, employees, agents, or licensors do not make any representations or warranties of any kind, including, but not limited to, express or implied warranties of fitness for a particular purpose or regarding the content or information in this document, to the full extent permitted by applicable law.

The information in this document does not constitute engineering or other professional advice, and any reliance users place on such information is therefore strictly at their own risk. Images and drawings provided within this document are for reference only and may not apply to all possible conditions. MTC Solutions shall not be liable for any loss or damage of any kind, including indirect, direct, incidental, punitive, or consequential loss or damage arising out of, or in connection with, the information, content, materials referenced, or the use of any of the systems described in this document. Users may derive other applications which are beyond MTC Solutions’ control. The inclusion of the systems or the implied use of this document for other applications is beyond the scope of MTC Solutions’ responsibility.

Published on February 1<sup>st</sup>, 2023, Copyright © 2023 by MTC Solutions. All rights reserved.

This document or any portion thereof may not be reproduced or used in any manner whatsoever without the expressed written permission of the publisher.

# TABLE OF CONTENTS

- GENERAL NOTES TO THE DESIGNER..... 9
- MTBL - MASS TIMBER BRACKET LIGHT..... 10
  - Applications..... 10
  - Associated Hardware..... 10
  - Reference Design Values in CLT ..... 11
  - Geometry Requirements ..... 13
  - Connector Detailing..... 13
  - Testing ..... 14
- BSP-S - SOLID BASE SHEAR PLATE ..... 17
  - Associated Hardware..... 17
  - Applications..... 17
  - Reference Design Values in CLT Shear Wall..... 18
  - Geometry Requirements ..... 18
  - Connector Detailing..... 18
- MTS15 - MASS TIMBER STRAP ..... 20
  - Associated Hardware..... 20
  - Applications..... 20
  - Reference Design Values in CLT ..... 21
  - Geometry Requirements ..... 21
- MTS-I - MASS TIMBER STRAPS INCLINE..... 22
  - Associated Hardware..... 22
  - Applications..... 22
  - Reference Design Values in CLT ..... 23
  - Geometry Requirements ..... 24
  - Connector Detailing..... 24
  - Installation Consideration ..... 25

# Mass Timber Hardware Specialist



At MTC Solutions, our core focus is to supply structural hardware for modern mass timber applications in commercial, industrial, and residential projects. We are proud to partner with leading industry experts, providing solutions and tools to design code-compliant buildings that are pushing the boundaries of the North American construction industry.

Our in-house team of mass timber specialists support professionals in designing connections that are tailored to the specific needs of each project, resulting in truly innovative and cost-efficient solutions. We are recognized as experts, moving the industry forward with tested and proven solutions.



## Expertise

We provide the knowledge and tools to help our customers build cutting-edge and code-compliant mass timber projects while pushing the boundaries of the North American construction industry.



## Commitment

We are dedicated to making your project a success, from design and installation support to delivering high quality products with speed and accuracy.



## North American Tailored Products

We partner with leading research facilities across North America to ensure our products are tested and customized to fit the unique needs of the market, from seismic considerations to solutions for large post and beam structures in various climates.



# Find Your Connection Solution

MTC Solutions provide the right tools to design code-compliant buildings, educating the mass timber industry on connection solutions.



Structural Screw Catalog



Structural Screw Connection Design Guide



Structural Fasteners



Accessories

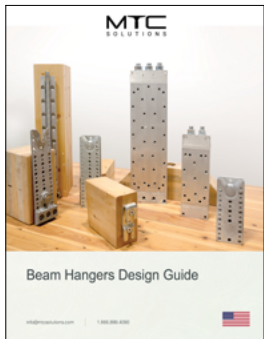

Beam Hangers Design Guide



Beam Hangers



Connector Design Guide



Connectors



Rigging Design Guide



Rigging Devices

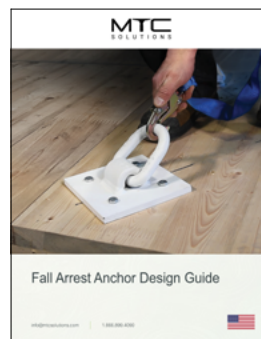

Fall Arrest Anchor Design Guide



Fall Arrest



**WHO  
ARE WE?**

# YOUR MASS TIMBER HARDWARE SUPPLIER

Rely on our distribution team to deliver your North American projects with speed and accuracy.

## LEADING WITH INNOVATION & RESEARCH

We are leading the mass timber industry with cutting edge connection solutions and partnering with renowned research facilities.

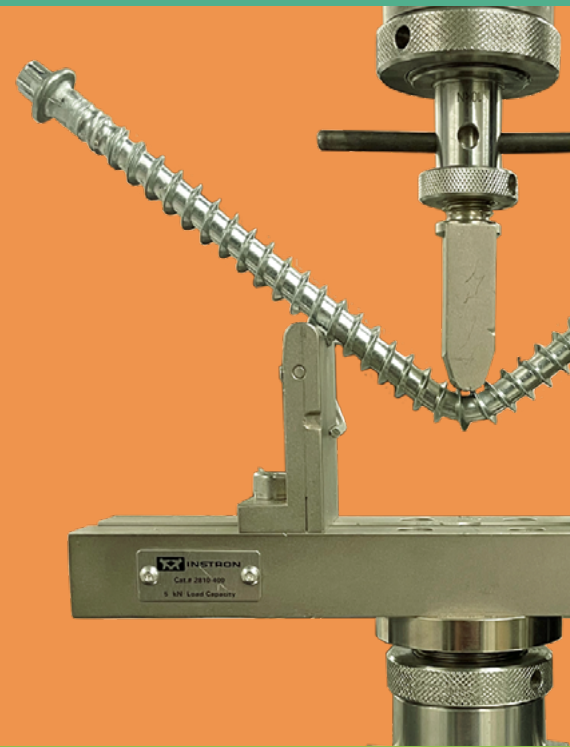

## WE MAKE YOU THE EXPERT

Learn about the right solutions for your projects and Mass Timber connections with our technical resources & support team!

# CONNECTIONS DESIGN SUPPORT

Reach out to the technical team for design support, from early design stages to ongoing iterative changes. We help find the most efficient connection solutions.

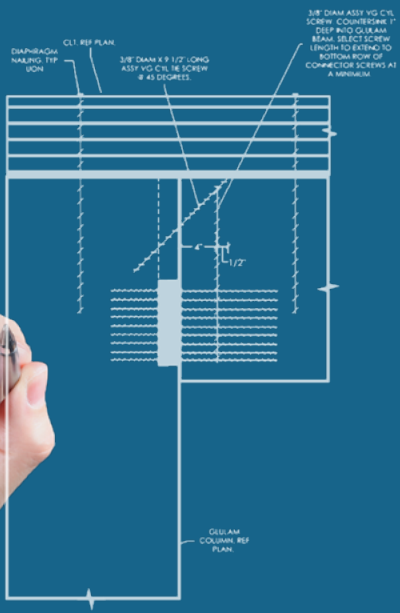

# MANUFACTURERS' HELP DESK

Use our comprehensive & practical resources to find the most cost-effective solutions for your structural elements.



# TESTED & PROVEN SOLUTIONS

Count on MTC Solutions' 10+ years of expertise, providing tested & proven ICC approved solutions, support, and resources.







# Clayton Community Centre

Surrey, BC



## General Notes To The Designer

1. All suggestions and details shown are to be treated as general and cannot be assumed to be valid for all construction requirements and specific site conditions.
2. Listed allowable loads are obtained based on tested values and analyzed using ASTM D7147 and D1761 standards.
3. Test based allowable loads are a minimum of ultimate load divided by 3, load at 1/8" displacement and system capacity based on individual fastener capacity with a factor of safety of 5.
4. Listed allowable loads are in the linear-elastic range of the connection.
5. Designers must ensure that all possible stress limits in the wood members, such as the shear capacity, the rolling shear capacity of the Cross Laminated Timber (CLT) or other material properties, are not exceeded and continuous load path is assured.
6. Allowable loads must be adjusted in accordance with all applicable adjustment factors of NDS-2018 Chapter 12, unless otherwise indicated.
7. Connectors in combination with carbon steel fasteners are to be used in dry service conditions only, with temperatures below 100F such that  $C_M = 1.0$  and  $C_t = 1.0$ .
8. For standard term loading, the load duration factor is  $C_D = 1$ . For short-term loading, the load duration factor is  $C_D = 1.6$ , per NDS-2018 Chapter 11.3.2.
9. Listed allowable loads apply to different timber species according to their respective specific gravities (G) per NDS-2018.
10. Cyclic test data have been analyzed using ASTM E2126 Equivalent Energy Elastic Plastic (EEEP) method and is used to report the ductility value for the connector. Based on North American standards, an energy dissipative connection must be moderately ductile, with ductility defined as the ratio of the ultimate displacement and the yield displacement during cyclic loading per ASTM E2126. These standards define moderately ductile connections as connections with a ductility ratio of 3.0 or higher. The ductility ratio for the tested connectors is listed in the appropriate tables.
11. Connections must respect the geometry requirements as specified in the connection Geometry Requirement sections of this guide.
12. Installation of the connector fasteners into voids, splits and gaps is to be avoided.
13. A design professional must be contacted immediately, and appropriate measures must be taken if splitting of the wood or wood-based material is observed during installation or prior to installation of the fasteners. A design professional must also be notified in instances of fastener damage or breakage.

# MTBL - Mass Timber Bracket Light

The Mass Timber Brackets Light are engineered from thin 1/16" galvanized steel with a reinforced perimeter and are easily installed with ASSY self-tapping screws. The MTBLs can withstand loads similar to thicker 1/8" steel brackets, providing a cost-effective solution.

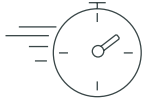

Fast Installation



Performance Based Design



Ductile Connection



MTBL 90

Code Approval



ETA

## Associated Hardware

### Fasteners and Installation Tools



ASSY Ecofast 3/16" x 2"



Countersunk Head



MTBL 105



AW 20 Bit

## Applications



Wall to Ceiling

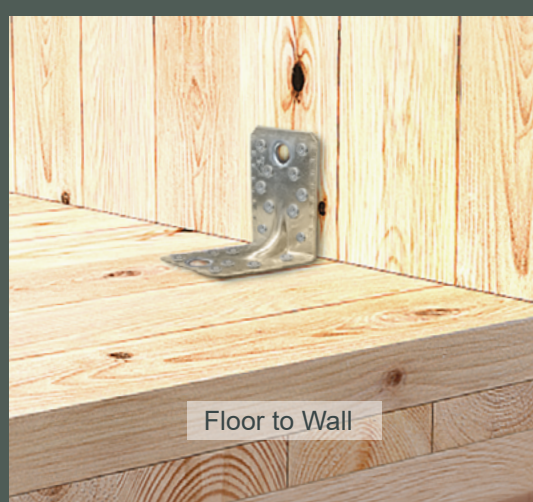

Floor to Wall



Wall to Wall

# Reference Design Values in CLT

Table 1, F1 - Allowable Lateral Loads in CLT Using MTBL

Configuration		Fasteners		Allowable Loads [lbs]		Estimated Slip Modulus [lbs / in]	Ductility Ratio	
	Angle Bracket	Specific Gravity	Type	Quantity	F1 - Lateral Loads			
					Standard Loading			Short Term Loading
MTBL 90	0.42	Ecofast	20	960	1,540	11,700	7.5	
MTBL 105	(SPF)	3/16" x 2"	26	1,400	2,240	17,500	10	

Table 2, F1 - Estimated Ultimate Lateral Loads in CLT Using MTBL

Configuration		Fasteners		Ultimate Loads [lbs]	
Angle Bracket	Specific Gravity	Type	Quantity	F1 - Lateral Loads	
				Estimated 5 <sup>th</sup> Percentile	Estimated 95 <sup>th</sup> Percentile
				MTBL 90	0.42
MTBL 105	(SPF)	3/16" x 2"	26	2,320	3,570

Notes:  
1. See detailed notes under table 4.

Table 3, F4 - Allowable Uplift Loads in CLT Using MTBL

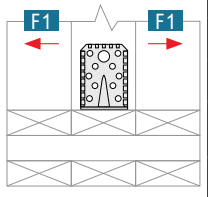
Configuration		Fasteners		Allowable Loads [lbs]		Estimated Slip Modulus [lbs / in]	Ductility Ratio	
	Angle Bracket	Specific Gravity	Type	Quantity	F4 - Uplift Loads			
					Standard Loading			Short Term Loading
MTBL 90	0.42	Ecofast	20	870	1,400	30,700	15.8	
MTBL 105	(SPF)	3/16" x 2"	26	940	1,500	24,350	14.6	

Table 4, F4 - Estimated Ultimate Uplift Loads in CLT Using MTBL

Configuration		Fasteners		Ultimate Loads [lbs]	
Angle Bracket	Specific Gravity	Type	Quantity	F4 - Uplift Loads	
				Estimated 5 <sup>th</sup> Percentile	Estimated 95 <sup>th</sup> Percentile
				MTBL 90	0.42
MTBL 105	(SPF)	3/16" x 2"	26	2,300	2,870

- Notes:
- Listed allowable loads are only valid for Allowable Stress Design in the USA.
  - Listed allowable loads are only valid for listed ASSY screws.
  - All connection design must meet all relevant requirements of General Notes to the Designer, page 7.
  - The MTBL were tested in monotonic and reverse cyclic loading configurations. Listed allowable loads are calculated using test data and test-based calculation methods.
  - The estimated slip modulus was derived from cyclic loading, in accordance with the EEEP method as detailed in ASTM E2126.
  - The ultimate load values at 5th and 95th percentile was derived based on at least 12 brackets tested in each loading orientation, in accordance with the EN 14358 standard.
  - For the MTBL 105, the reference design values presented in this guide assume side B is always perpendicular to the load direction "F4" and parallel to the load directions "F2" and "F3". The load direction "F1" is independent of install direction. See page 11.
  - Connector placement must respect the requirements presented in the MTBL Geometry Requirements section, page 11.
  - The maximum installation torque for the 3/16" diameter ASSY Ecofast screws is 2.5 lbs-ft.

Load Direction

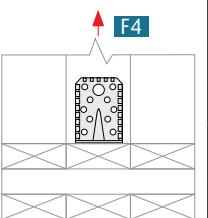
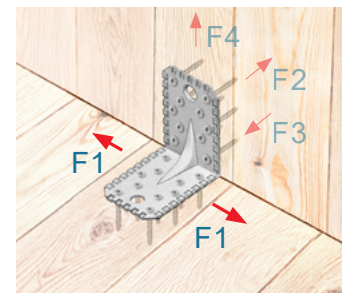

Load Direction

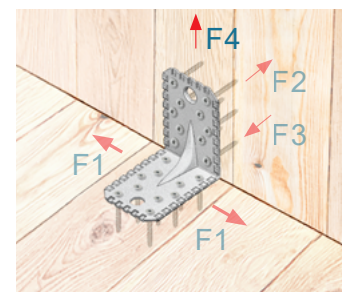



Table 5, F2 - Allowable Withdrawal Loads in CLT Using MTBL

Configuration		Fasteners			Allowable Loads [lbs]		Estimated Slip Modulus [lbs / in]
	Angle Bracket	Specific Gravity	Type	Quantity	F2 - Withdrawal Loads		
					Standard Loading	Short Term Loading	
	MTBL 90	0.42	Ecofast	20	830	1,300	21,200
	MTBL 105	(SPF)	3/16" x 2"	26	1,160	1,850	29,700

Table 6, F2 - Estimated Ultimate Withdrawal Loads in CLT Using MTBL

Configuration		Fasteners		Ultimate Loads [lbs]	
Angle Bracket	Specific Gravity	Type	Quantity	F2 - Withdrawal Loads	
				Estimated 5 <sup>th</sup> Percentile	Estimated 95 <sup>th</sup> Percentile
				MTBL 90	0.42
MTBL 105	(SPF)	3/16" x 2"	26	2,790	4,320

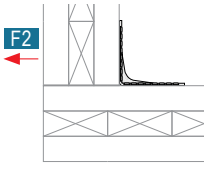
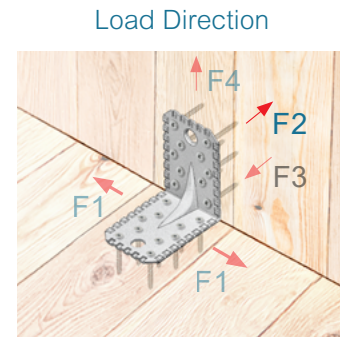

Notes:  
1. See detailed notes under table 8.

Table 7, F3 - Allowable Compression Loads in CLT Using MTBL

Configuration		Fasteners			Allowable Loads [lbs]		Estimated Slip Modulus [lbs / in]
	Angle Bracket	Specific Gravity	Type	Quantity	F3 - Compression Loads		
					Standard Loading	Short Term Loading	
	MTBL 90	0.42	Ecofast	20	1,150	1,840	10,450
	MTBL 105	(SPF)	3/16" x 2"	26	1,150	1,840	18,000

Table 8, F3 - Estimated Ultimate Compression Loads in CLT Using MTBL

Configuration		Fasteners		Ultimate Loads [lbs]	
Angle Bracket	Specific Gravity	Type	Quantity	F3 - Compression Loads	
				Estimated 5 <sup>th</sup> Percentile	Estimated 95 <sup>th</sup> Percentile
				MTBL 90	0.42
MTBL 105	(SPF)	3/16" x 2"	26	3,260	3,620



- Notes:
- Listed allowable loads are only valid for Allowable Stress Design in the USA.
  - Listed allowable loads are only valid for listed ASSY screws.
  - All connection design must meet all relevant requirements of General Notes to the Designer, page 7.
  - The MTBL were tested in monotonic and reverse cyclic loading configurations. Listed allowable loads are calculated using test data and test-based calculation methods.
  - The estimated slip modulus was derived from cyclic loading, in accordance with the EEEP method as detailed in ASTM E2126.
  - The ultimate load values at 5th and 95th percentile was derived based on at least 12 brackets tested in each loading orientation, in accordance with the EN 14358 standard.
  - For the MTBL 105, the reference design values presented in this guide assume side B is always perpendicular to the load direction "F4" and parallel to the load directions "F2" and "F3". The load direction "F1" is independent of install direction. See page 11.
  - Connector placement must respect the requirements presented in the MTBL Geometry Requirements section, page 11.
  - The maximum installation torque for the 3/16" diameter ASSY Ecofast screws is 2.5 lbs-ft.

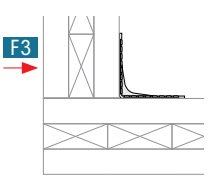
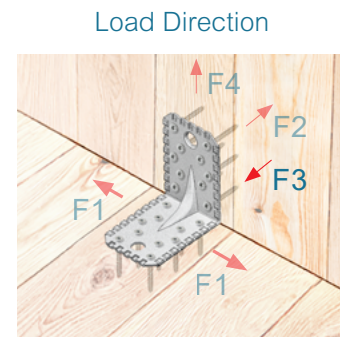

## Geometry Requirements

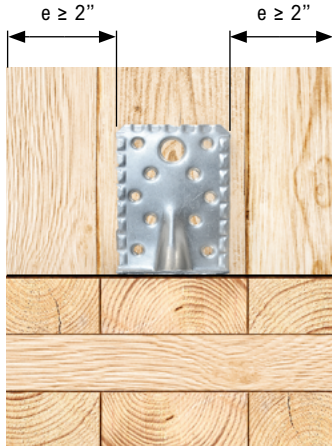

**MTBL 90**  
Front View



**MTBL 105**  
Front View

**Notes:**

- Distances "e" are minimum edge distances.

## Connector Detailing

**MTBL 90**

**MTBL 105**

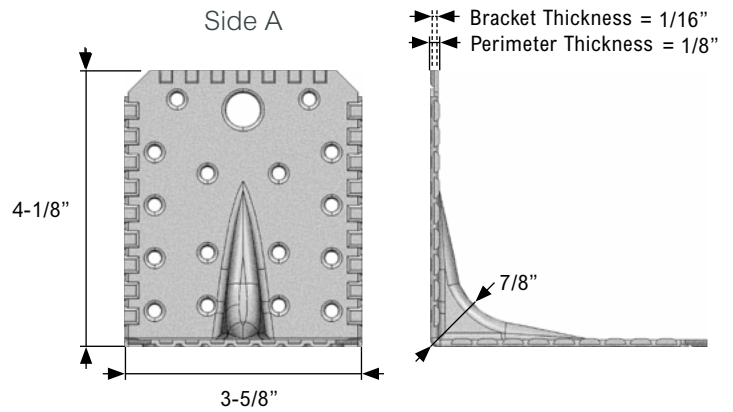
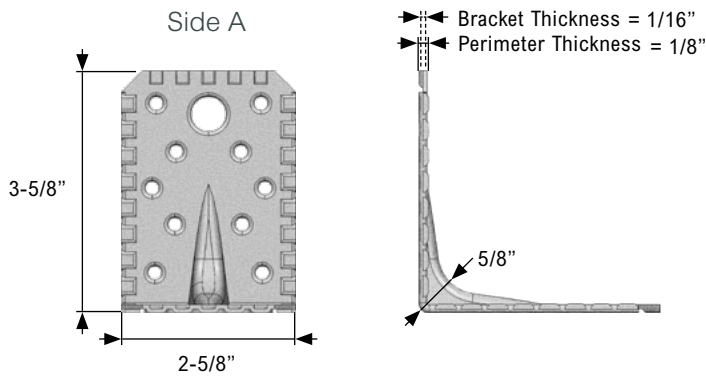

**Notes:**

- All 3/16" holes are to be filled.
- For the MTBL 105, the reference design values presented in this guide assume side B always perpendicular to the load direction "F4" and parallel to the load directions "F2" and "F3". The load direction "F1" is independent of install direction.

## Testing

### Data Analysis

The load-displacement graphs presented in this section show hysteresis loops and envelope curves and have been selected to show an average result from a set of tests. The envelope curves were obtained from the hysteresis loop created by the reverse cyclic tests.

For the reverse cyclic test, ASTM E2126 was followed to analyze the results. Analysis has shown that the MTBL angle brackets have an average ductility ratio of 3 or more in all loading directions following the Equivalent Energy Elastic-Plastic (EEEP) method in both monotonic and cyclic loading conditions.

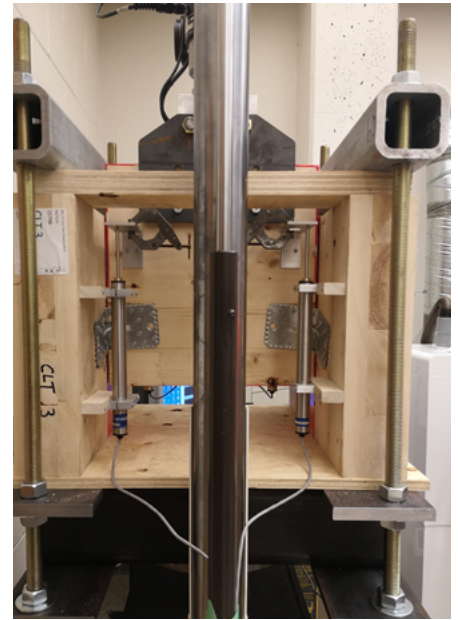

## F1 - Lateral Load / Displacement Curves in CLT

### MTBL 90

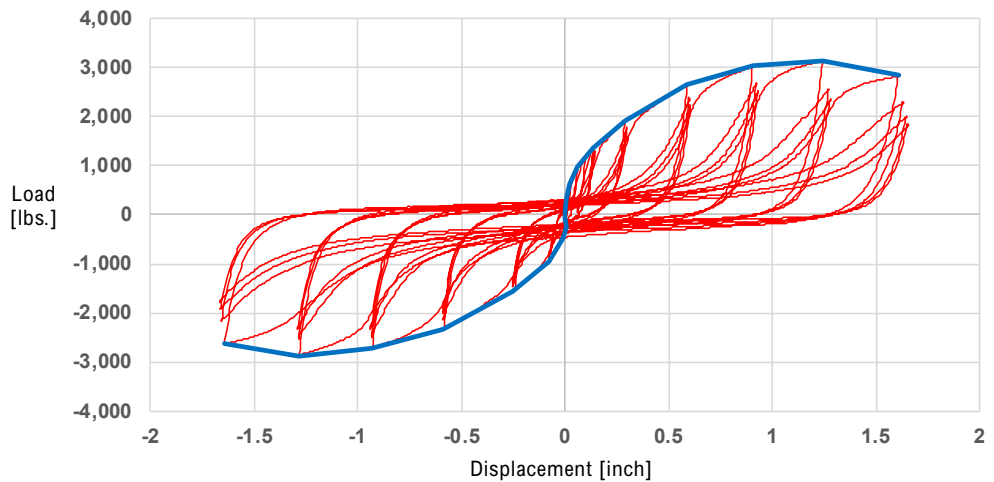

### MTBL 105

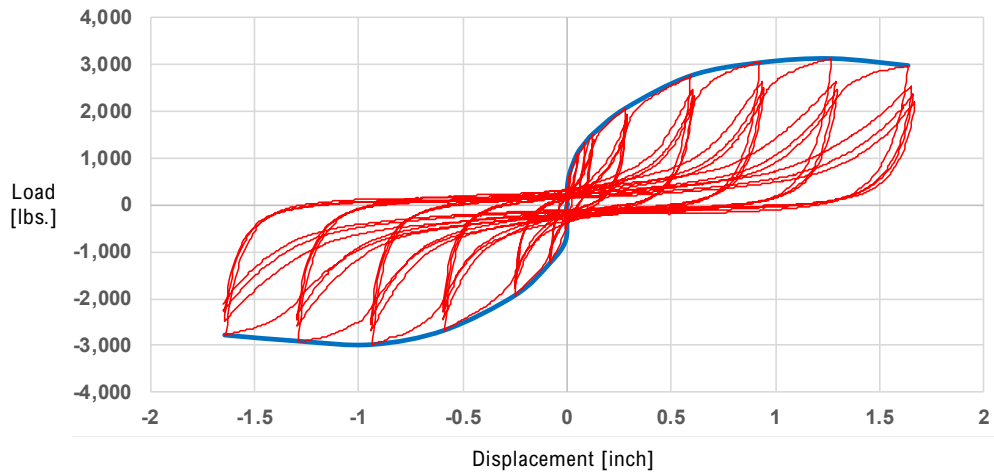

**Notes:**

1. The MTBLs were tested in monotonic and reverse cyclic loading configurations.
2. Graphs shown represent an average result recorded in the tests.

## Data Analysis

The witnessed failure modes varied depending on loading direction, however, ductile steel failure and ductile screw yielding were the prevalent failure modes observed. In load directions F1 Lateral and F3 Compression, steel yielding was recorded. In load directions F2 Withdrawal and F4 Uplift, both screw withdrawal and steel yielding was observed.

Throughout the testing, it was observed that the MTBL 90 and the MTBL 105 performed similarly in a variety of selected test setups. This result is due to similarities in the design of each MTBL with respect to hole patterns and the amount and location of fasteners on each leg.

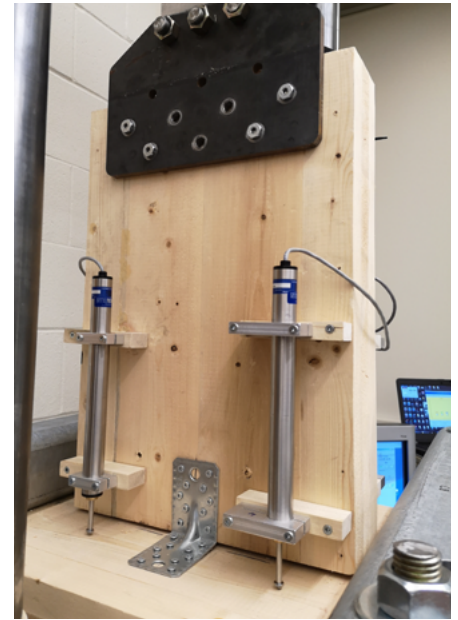

## F4 - Uplift Load / Displacement Curves in CLT

### MTBL 90

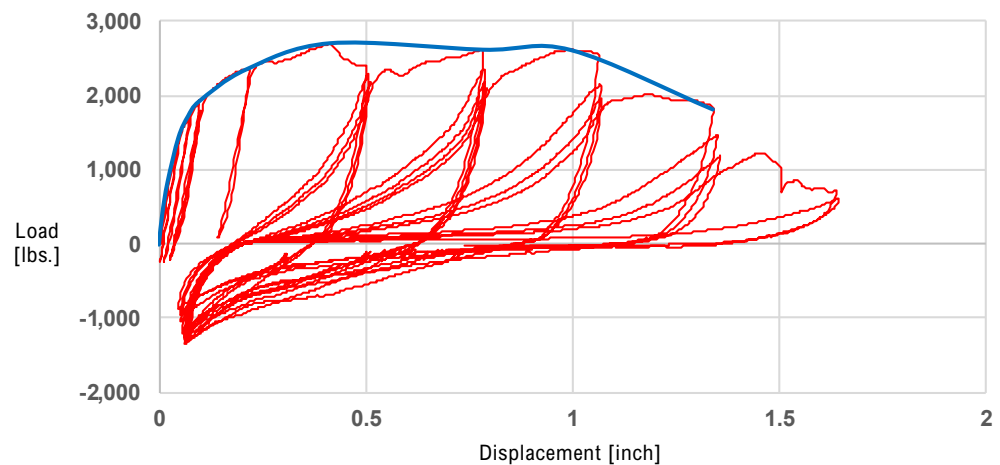

### MTBL 105

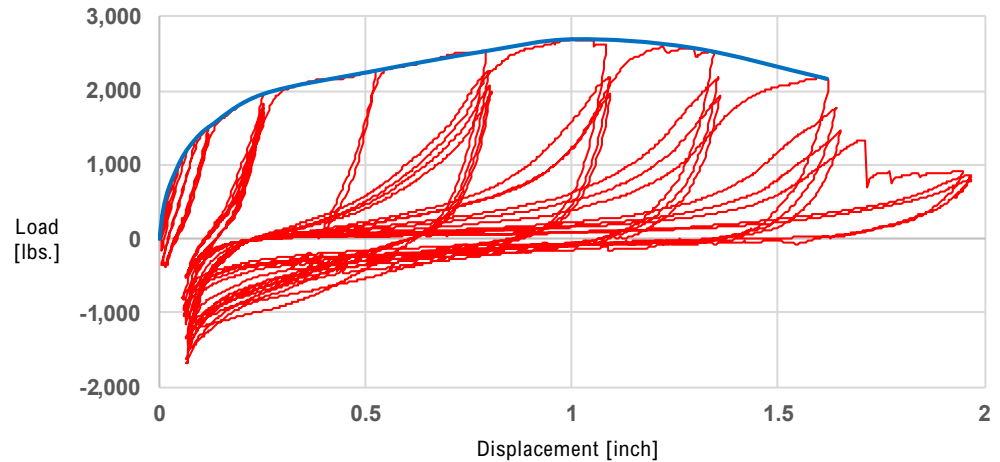

**Notes:**

1. The MTBLs were tested in monotonic and reverse cyclic loading configurations.
2. Graphs shown represent an average result recorded in the tests.





# First Tech Federal Credit Union

Hillsboro, Oregon



# BSP-S - Solid Base Shear Plate

The BSP-S Solid Base Shear Plate connector is designed for high strength shear connections in seismic applications. The BSP-S is easily installed on CLT shear walls using high-capacity code approved ASSY self-tapping screws. The failure mechanism of the BSP-S connector is designed to be the screw yielding in failure mode IIIS or IV.



High Capacity Connector

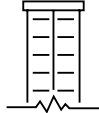

Seismic Applications



Fast Installation



BSP-S

Code Approval



## Associated Hardware

### Fasteners and Installation Tools

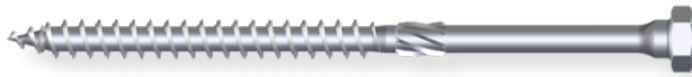

ASSY Kombi 1/2" x 5-1/2"



Hexagonal Head



11/16" Magnetic Socket  
Specified Magnetic Socket Bit for Installation

\*\*Hardware package does not include the concrete anchors

## Applications



CLT Shear Wall to Concrete Foundation



# Reference Design Values in CLT Shear Wall

Table 9, F1 - Allowable Lateral Loads in CLT Using BSP-S

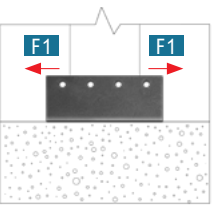
Configuration	Fasteners			Allowable Loads [lbs]	
	Specific Gravity	Type	Quantity	F1 - Lateral Loads	
				Standard Loading $C_D = 1.0$	Short Term Loading $C_D = 1.6$
	0.42 (SPF)	Kombi 1/2" x 5-1/2"	4	6,066	9,706

- Notes:
1. Listed allowable loads are only valid for Allowable Stress Design in the USA.
  2. Listed allowable loads are only valid for listed ASSY screws.
  3. All connection design must meet all relevant requirements of General Notes to the Designer, page 7.
  4. Listed allowable loads are calculated using test data and test-based calculation methods.
  5. Connector placement must respect the requirements presented in the BSP-S Geometry Requirements section.
  6. The maximum installation torque for the 1/2" diameter ASSY Kombi screw is 38.5 lbs-ft.
  7. The failure mode observed for the steel to wood portion of the BSP-S is yielding of the self-tapping screws in mode III S or IV.
  8. No uplift forces shall be assigned to the base shear connections.
  9. The BSP-S system must be fastened using anchor rods that are designed to transfer the full allowable load or more as shown in Table 9.

## Geometry Requirements

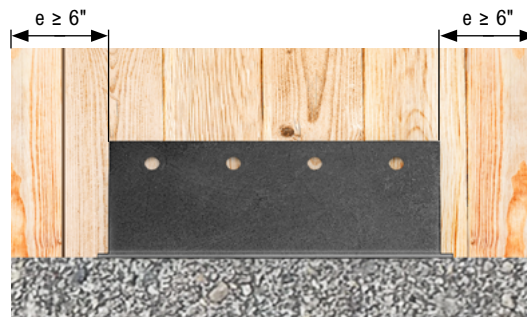

Front View

- Notes:
1. Distances "e" are minimum end distances.

## Connector Detailing

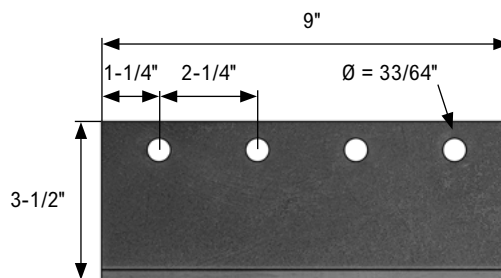

Front View

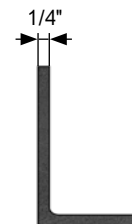

Side View

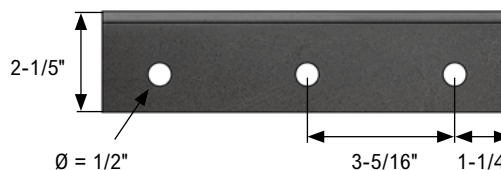

Top View

- Notes:
1. All 33/64" holes are to be filled with ASSY Kombi 1/2" x 5-1/2".
  2. All 1/2" holes are to be filled with anchor rods (refer to note 9 under Table 9).





# Ritchie Market

Edmonton, Alberta



# MTS15 - Mass Timber Strap

The Mass Timber Strap 15 is a tested high-capacity connector designed for use in various mass timber elements. The MTS15 is an ideal solution for tension applications using strong code approved ASSY self-tapping screws for a fast and easy installation.

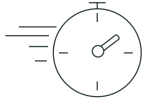

Fast Installation

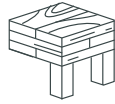

Mass Timber Panels



Performance Based Design

Code Approval



## Associated Hardware

Fasteners and Installation Tools

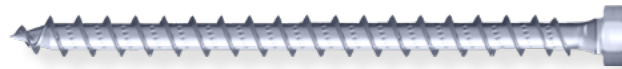

ASSY Kombi LT 1/2" x 6-1/4"



Hexagonal Head



11/16" Magnetic Socket

Specified Magnetic Socket Bit for Installation

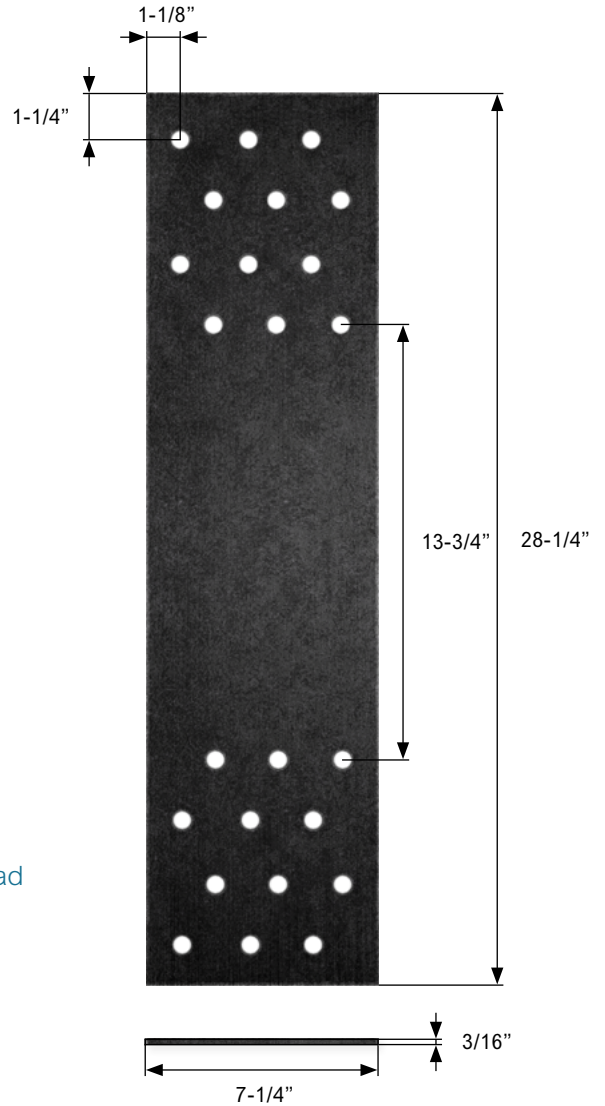

## Applications

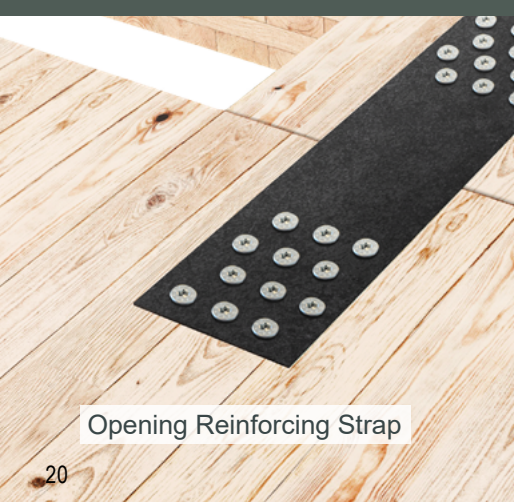

Opening Reinforcing Strap



Wall Strap



Diaphragm Strap



# Reference Design Values in CLT

Table 10, Tested Allowable Loads in CLT Using MTS15

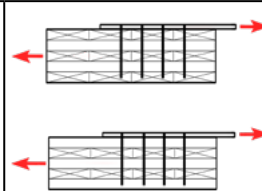
CLT Panel & Plate Configuration			Fasteners		Allowable Loads [lbs]		Estimated Slip Modulus [lbs / in]		
	Specific Gravity	Panel Thickness [in]	Type	Quantity	Standard Loading $C_o = 1.0$	Short Term Loading $C_o = 1.6$			
<b>5 PLY +</b>	<b>Z</b>		SPF (0.42)	$\geq 6-7/8"$	Kombi LT 1/2" x 6-1/4"	24	13,900	22,240	147,500

**Notes:**

1. Listed allowable loads are only valid for Allowable Stress Design in the USA.
2. Listed allowable loads are only valid for listed ASSY screws.
3. All connection design must meet all relevant requirements of General Notes to the Designer, page 7.
4. Listed allowable loads are calculated using test data and test-based calculation methods.
5. Connector placement must respect the requirements presented in the MTS 15 - Geometry Requirements section.
6. Shall pre-drilling be required, a 1/4" diameter drill bit may be used for pre-drilling.
7. The maximum installation torque for the 1/2" diameter ASSY Kombi screws is 38.5 lbs-ft.

## Geometry Requirements

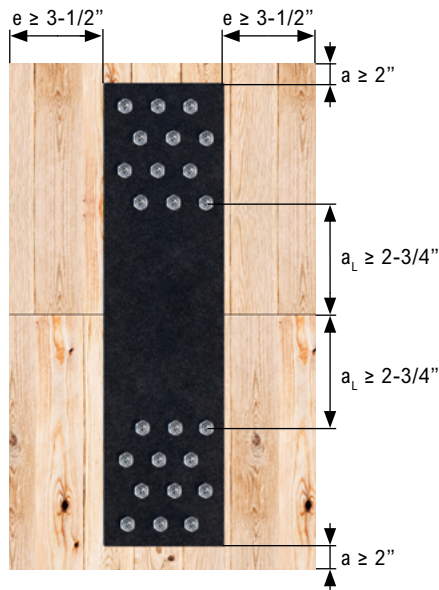

Diaphragm Strap Installation  
Top View

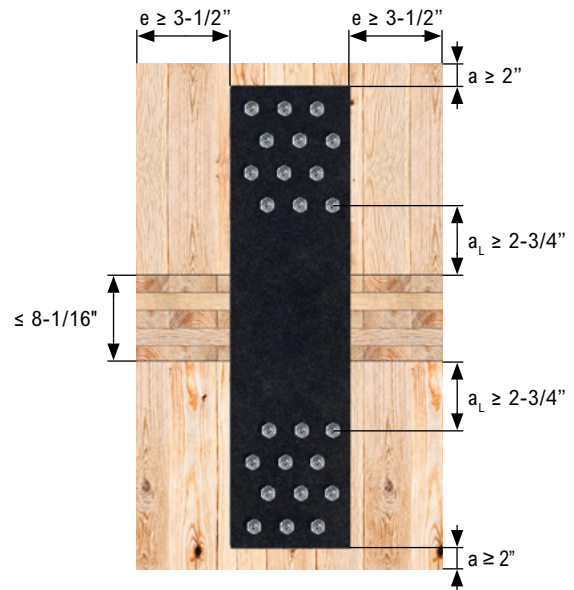

Wall Strap Installation  
Front View

**Notes:**

1. All geometry requirements are in accordance with the testing performed.
2. Distances "a" are minimum end distances.
3. Distances "a<sub>L</sub>" are minimum loaded end distances.
4. Distances "e" are minimum edge distances.

# MTS-i - Mass Timber Straps Incline

The MTS-i Mass Timber Strap series offers two solutions: the MTS-i 30 and the MTS-i 40 series. The MTS-i 30 and MTS-i 40 are designed to be a capacity protected connection in mass timber structures and are easy to install with code approved ASSY self-tapping screws and 45-degree washers. By using high strength inclined screws, the MTS-i offers higher stiffness and capacity for various tension applications, making it a one-of-a-kind off the shelf connecting solution.



Fast Installation

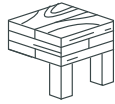

Mass Timber Panels



High Capacity Connector

## Associated Hardware

### Fasteners and Installation Tools



ASSY VG CSK 5/16" x 8-5/8"

Countersunk Head



45° Washer



MTS-i 30



MTS-i 40



## Applications



Opening Reinforcing Strap



Wall Strap



Diaphragm Strap



Spline Connection Reinforcement

# Reference Design Values in CLT

Table 11, Allowable Loads in CLT Using MTS-i 30

CLT Panel & Plate Configuration			Fasteners		Allowable Loads [lbs]		
		Panel Thickness [in]	Specific Gravity	Type	Quantity	Standard Loading $C_D = 1.0$	Short Term Loading $C_D = 1.6$
<b>5 PLY +</b>	<b>Z</b>		SPF (0.42)	VG CSK 5/16" x 8-5/8"	30	11,067	17,707
			D.Fir (0.49)			11,765	18,824

Table 12, Estimated Ultimate Loads in CLT Using MTS-i 30

Configuration		Fasteners		Ultimate Loads [lbs]	
Tension Strap	Specific Gravity	Type	Quantity	F1 - Lateral Resistance	
				Estimated 5 <sup>th</sup> Percentile	Estimated 95 <sup>th</sup> Percentile
<b>MTS-i 30</b>	SPF (0.42)	VG CSK 5/16" x 8-5/8"	30	41,272	56,511
	D.Fir (0.49)			48,238	58,099

Notes:

- See detailed notes under Table 14.

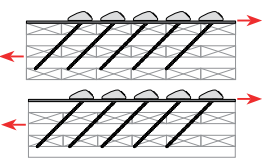
Table 13, Allowable Loads in CLT Using MTS-i 40

CLT Panel & Plate Configuration			Fasteners		Allowable Loads [lbs]		
		Panel Thickness [in]	Specific Gravity	Type	Quantity	Standard Loading $C_D = 1.0$	Short Term Loading $C_D = 1.6$
<b>5 PLY +</b>	<b>Z</b>		SPF (0.42)	VG CSK 5/16" x 8-5/8"	40	14,756	23,610
			D.Fir (0.49)			15,687	25,099

Table 14, Estimated Ultimate Loads in CLT Using MTS-i 40

Configuration		Fasteners		Ultimate Loads [lbs]	
Tension Strap	Specific Gravity	Type	Quantity	F1 - Lateral Resistance	
				Estimated 5 <sup>th</sup> Percentile	Estimated 95 <sup>th</sup> Percentile
<b>MTS-i 40</b>	SPF (0.42)	VG CSK 5/16" x 8-5/8"	40	55,030	75,348
	D.Fir (0.49)			64,317	77,465

Notes:

- Listed allowable loads are only valid for Allowable Stress Design in the USA.
- Listed allowable loads are only valid for listed ASSY screws.
- All connection design must meet all relevant requirements of General Notes to the Designer, page 7.
- Fasteners and 45-degree washers must be placed according to the Installation Considerations section "B" on page 21.
- Screw installation shall start with the inner most screw of the tension strap as shown in Installation Consideration section "C" on page 21.
- Connector placement must respect the requirements presented in the MTS-i Geometry Requirements section on page 20.
- Shall pre-drilling be required, a 3/16" diameter drill bit may be used for pre-drilling.
- The maximum installation torque for the 5/16" diameter VG CSK screws is 13.6 lbs-ft.

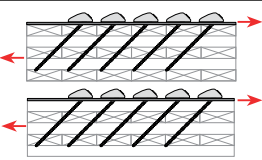

## Geometry Requirements

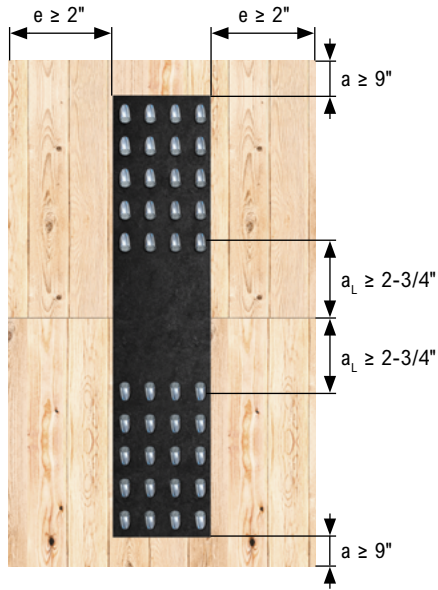

Diaphragm Strap Installation

Top View

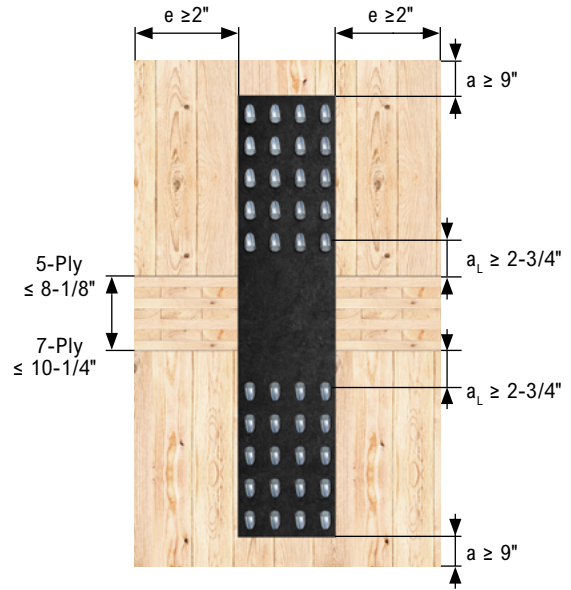

Wall Strap Installation

Front View

Notes:

1. Listed geometry requirements are valid for both MTS-i 30 and MTS-i 40
2. Distances "a" are minimum end distances.
3. Distances "a<sub>L</sub>" are minimum loaded end distances.
4. Distances "e" are minimum edge distances.
5. Dimensions not to scale.

## Connector Detailing

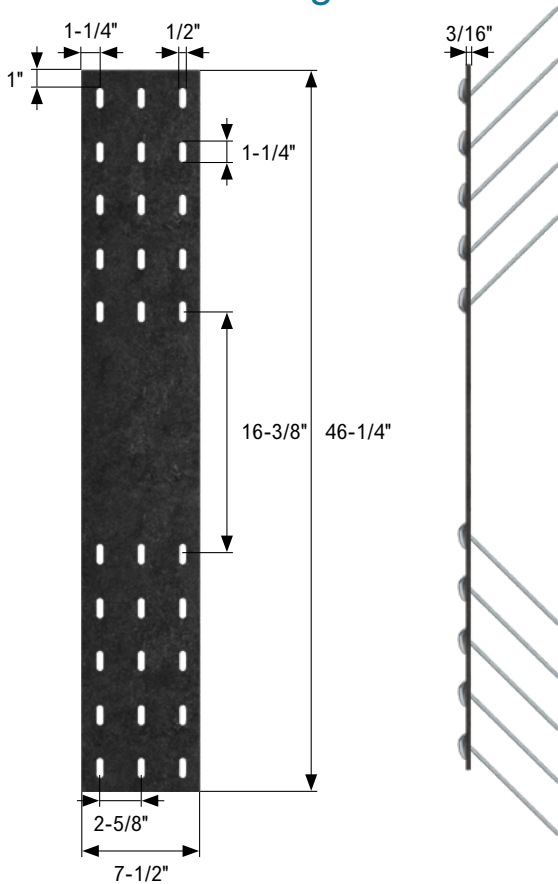

MTS-i 30

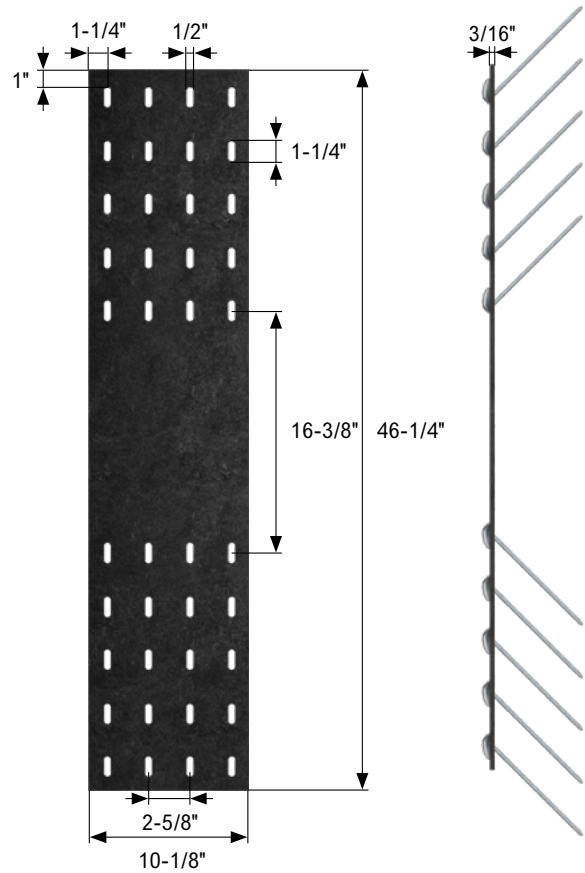

MTS-i 40

## Installation Consideration

### A Correct Drill for Installation

A cordless or corded drill with at least 18V must be used for the screw installation. The use of impact drills is prohibited. The maximum torque for 5/16" diameter screw is 13.57 lbs.ft.

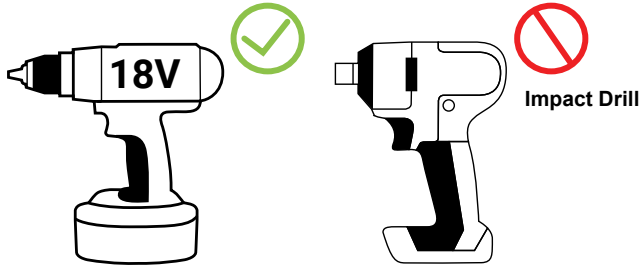

### B Washer Orientation

Washers must be installed so that the screw tip is pointing to the outside of the tension strap, not the middle.

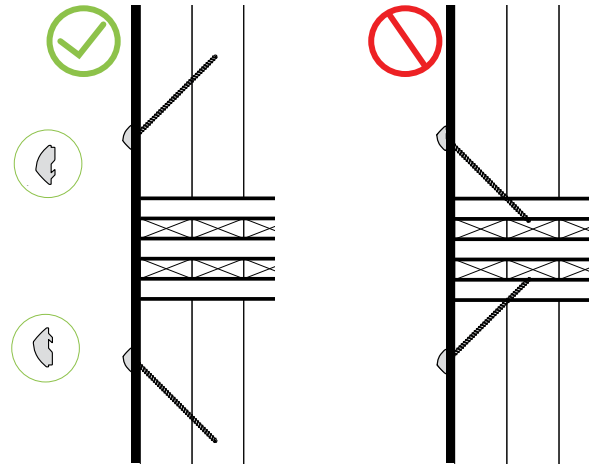

### C Order of Screw Installation

To ensure the tension screws are properly engaged and loads are transferred through the tension strap, the screws must be installed starting from the inner most screw row [A] to the outermost screws [D]. See the order of installation shown below.

Failure to install the tension strap with the correct screw order may result in the tension screws engaging and pushing the connector out of place.

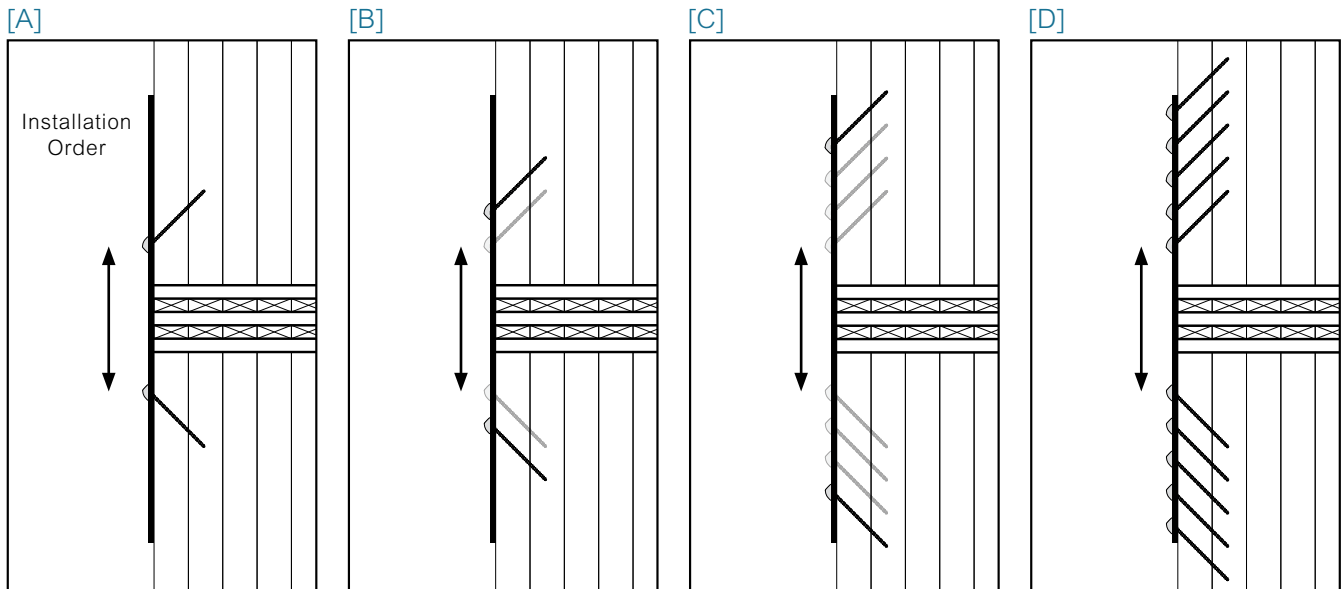

MTC Solutions provides sustainable, high quality mass timber connection solutions to a rapidly evolving and thriving industry. We drive innovation through certified research and development and contribute our part to the education of young talent and experienced professionals in the technology used in sustainable design.









**MTC**  
SOLUTIONS

---

[info@mtcsolutions.com](mailto:info@mtcsolutions.com)

1.866.899.4090

---

[mtcsolutions.com](http://mtcsolutions.com)

---

