

SWG ASSY 3.0 WOOD SCREWS

Special Provision



January 1, 2020

Subject: Substitution of Lag Screws with SWG ASSY 3.0 Wood Screws

Lag screws are ever-present in the timber construction industry, however labor intensive installation requirements make lag screws a difficult to work with solution for wood-to-wood or even steel to wood connections. Code approved ASSY 3.0 Wood Screws present numerous advantages over traditional lag screws as they are self-tapping and no pre-drilling is required in most circumstances. ASSY wood screws can be used as a labor-saving substitute for lag screws in most cases, for fasteners under simple shear forces.

Self-tapping screws offer comparable lateral capacities to lag screws and faster installation. This document is to be read in conjunction with the **National Design Standard (NDS) 2018** and ICC ESR-3179 for SWG ASSY 3.0 Wood Screws. The following substitution tables show adequate self-tapping screw replacements for given lag screw geometry that meet or exceed load-carrying capacities calculated for single lag screw connections.

In shear applications, the lag screw or equivalent ASSY screw must penetrate a minimum of 6D into the main member, where D is the screw outside thread diameter (major diameter). A detailed analysis of the substitution must be carried if group effects are applicable for the connection under consideration. MTC Solutions recommends that for lag screws in simple shear applications the fastener be substituted with specified ASSY Ecofast (Eco) or ASSY SK for wood to wood connections and ASSY Eco or ASSY Kombi for steel to wood connections.

It is important to note that spacing requirements are different for lag screws and self-tapping screws. To maintain the same spacing requirements, the self-tapping screws would need to be pre-drilled.

Sincerely,
MTC Solutions

General Information

Notes to the Designer

1. Substitution only valid for ASSY® fastener for Single Shear (two member) Connections in S.P.F. (G = 0.42) and D.Fir (G=0.49) in accordance with NDS 2018.
2. Group effects have not been considered and adjustment factors are assumed to not be required.
3. Head pull-through capacity does not govern the axial design of the lag screw.

ASSY® Ecofast

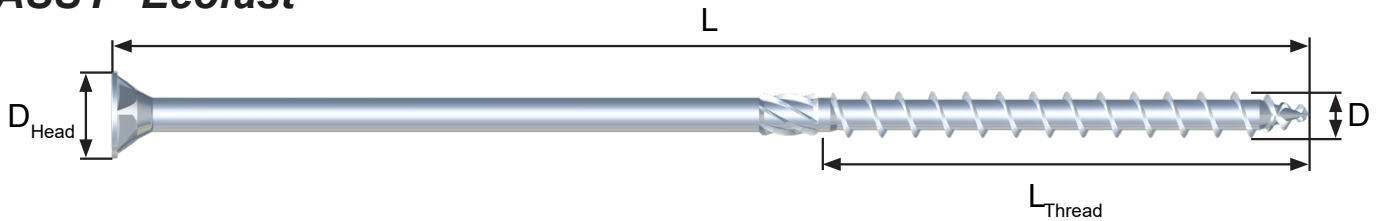

Item#	Box size	D	L	L _{Thread}	D _{Head}	Bit
#	pieces	in. [mm]	in. [mm]	in. [mm]	in. [mm]	
110060060000100	200	1/4 [6]	2-3/8 [60]	1-1/2 [37]	0.472 [12]	AW 30
110060080000100	100		3-1/8 [80]	2 [50]		
110060100000100	100		4 [100]	2-3/8 [60]		
110060120000100	100		4-3/4 [120]	2-3/4 [70]		
110060140000100	100		5-1/2 [140]	2-3/4 [70]		
110080080000300	75	5/16 [8]	3-1/8 [80]	2 [50]	0.591 [15]	AW 40
110080090000300	75		3-1/2 [90]	2-3/8 [60]		
110080100000300	75		4 [100]	2-3/8 [60]		
110080120000300	75		4-3/4 [120]	3-1/8 [80]		
110080140000300	75		5-1/2 [140]	3-1/8 [80]		
110080160000300	75		6-1/4 [160]	3-1/8 [80]		
110100100000300	50	3/8 [10]	4 [100]	2-3/8 [60]	0.728 [18.5]	AW 40
110100160000300	50		6-1/4 [160]	4 [100]		

Notes: For more ASSY® fastener options, visit mtcsolutions.com

ASSY® SK

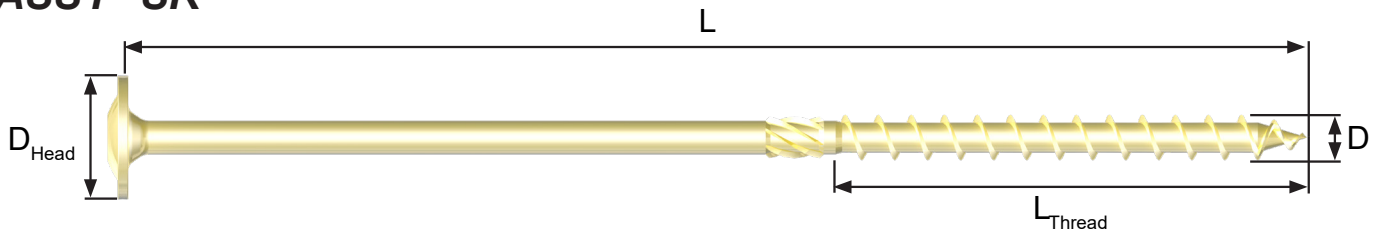

Item#	Box size	D	L	L _{Thread}	D _{Head}	Bit
#	pieces	in. [mm]	in. [mm]	in. [mm]	in. [mm]	
120120020000300	25	1/2 [12]	7-7/8 [200]	4 [100]	1.157 [29.4]	AW 50
120120022000300	25		8-5/8 [220]	4-3/4 [120]		

Notes: For more ASSY® fastener options, visit mtcsolutions.com

ASSY® Kombi

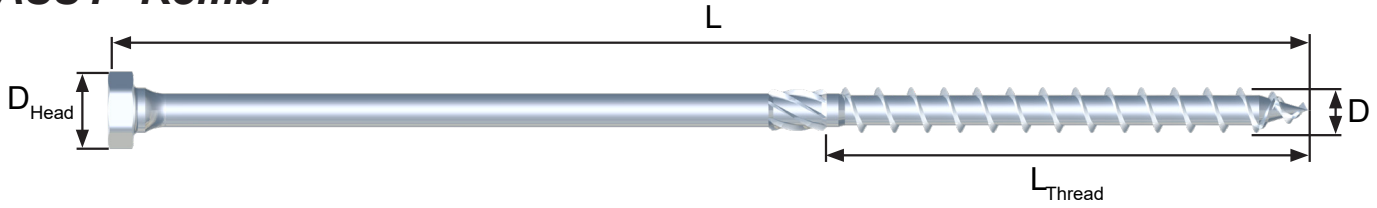

Item#	Box size	D	L	L _{Thread}	D _{Head}	Bit
#	pieces	in. [mm]	in. [mm]	in. [mm]	in. [mm]	
130080080000103	75	5/16 [8]	3-1/8 [80]	2 [50]	0.472 [12]	AW 40 or 1/2 Socket
130100100000103	50	3/8 [10]	4 [100]	2-3/8 [60]	0.591 [15]	AW 40 or 19/32 Socket
130120180000103	50	1/2 [12]	6-1/4 [160]	5-3/4 [145]	0.669 [17]	AW 40 or 11/16 Socket

Notes: For more ASSY® fastener options, visit mtcsolutions.com

Bits - AW® Drive

The AW® Bits are engineered and patented for proper installation of all ASSY® screws and offer exceptional fit and durability. They are available in three standard sizes.



AW® 30



AW® 40



AW® 50

Pre-drilling Recommendations

Table I.1, Pre-drilling hole diameter

Major Diameter (D)	Softwood	Hardwood	Steel Plate
in. [mm]	in. [mm]	in. [mm]	in. [mm]
1/4 [6]	5/32 [4]	5/32 [4]	9/32 [7]
5/16 [8]	3/16 [5]	15/64 [6]	23/64 [9]
3/8 [10]	15/64 [6]	17/64 [7]	7/16 [11]
1/2 [12]	17/64 [7]	5/16 [8]	33/64 [13]

Notes:

1. Consult a qualified design professional before pre-drilling.
2. Pre-drilled holes that exceed the diameters listed above may reduce the capacity of the screws.
3. Recommendations only applicable to ASSY® screws.
4. Connection design must meet all the relevant requirements outlined in the Notes to the Designer section.

Lag Screw Substitution Tables

Table T.1, Wood to Wood Lag Screw Substitution Tables

Lag Screw		Wood Side Member Thickness, T (in)								
D (in)	L (in)	1/2	5/8	3/4	1	1-1/4	1-1/2	1-3/4	2-1/2	3-1/2
1/4	3	N/A	Eco 1/4 x 3-1/8					Eco 1/4 x 4	N/A	N/A
	4	N/A							N/A	N/A
	5 to 12	N/A							Eco 1/4 x 4-3/4	
5/16	4	N/A	Eco 5/16 x 3-1/8	Eco 5/16 x 4	N/A	N/A	N/A	N/A	N/A	
	5	N/A			N/A	N/A				
	6	N/A			Eco 5/16 x 5-1/2	N/A				
	7 to 12	N/A			Eco 5/16 x 6-1/4					
3/8	4	N/A	Eco 3/8 x 3-1/8	N/A	N/A	N/A	N/A	N/A	N/A	
	5	N/A		N/A	N/A					
	6	N/A		N/A	N/A					
	7 to 12	N/A		Eco 3/8 x 6-1/4						
1/2	6	N/A	N/A	N/A	N/A	N/A	N/A	N/A	N/A	
	7	N/A	N/A	N/A	N/A	SK 1/2 x 7-7/8	N/A	N/A		
	8 to 12	N/A	N/A	N/A	N/A		SK 1/2 x 8-5/8			

Notes:

- Substitution only valid for ASSY® fastener for Single Shear (two member) Connections in S.P.F. (G = 0.42) and D.Fir (G=0.49) in accordance with NDS 2018.
- Substitution are based on capacities shown in Table 12J of NDS 2018.
- Connection geometry for ASSY screw, presented in the Detailing Section, must be respected.
- Substitution valid for Z_{\parallel} , Z_{\perp} , $Z_{\perp L}$ and $Z_{\perp T}$.
- N/A stands for Not Applicable. It either means there are no available ASSY substitution or the connection does not follow the minimum penetration requirements.

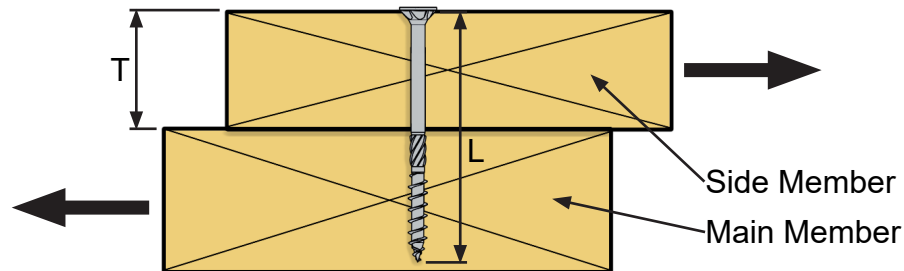
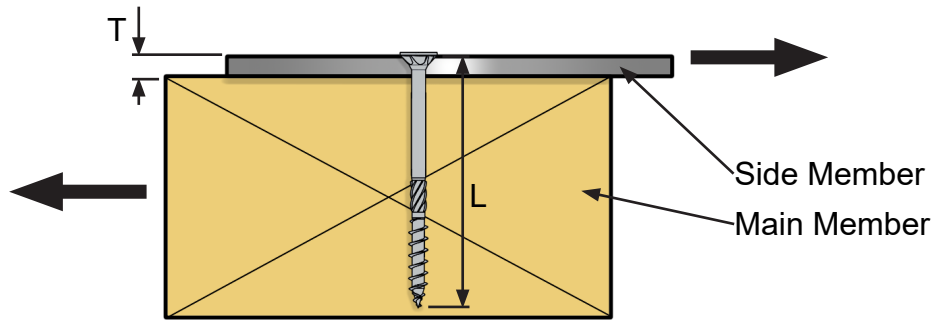

Table T.2, Steel to Wood Lag Screw Substitution Tables

Lag Screw		Steel Side Plate Thickness, T ASTM A36							
D (in)	L (in)	14ga	12ga	11ga	10ga	7ga	3ga	1/4"	
1/4	2 to 12	Eco 1/4 x 2-3/8					Eco 1/4 x 3-1/8		
5/16	3 to 12	Kombi 5/16 x 2-3/8					Kombi 5/16 x 3-1/8		
3/8	4 to 12	Kombi 3/8 x 3-1/8							
1/2	5 to 12	Kombi 1/2 x 5-1/2							

Notes:

1. Substitution only valid for ASSY® fastener for Single Shear (two member) Connections in S.P.F. (G = 0.42) and D.Fir (G=0.49) in accordance with NDS 2018.
2. Substitution are based on capacities shown in Table 12K of NDS 2018.
3. Connection geometry for ASSY screw, presented in the Detailing Section, must be respected.
4. Substitution valid for $Z_{||}$ and Z_{\perp} .



Spacing and Edge Distance Requirements

Spacing and distance requirements ensure full fastener resistance can be developed. Self-tapping screws displace wood fiber as the screw is driven into the member, while pre-drilling removes wood fiber. The spacing and edge distance requirements

for self-tapping screws, vary when compared to other fasteners. If pre-drilling is implemented, the spacing and edge distance requirements as per NDS 2018 may apply.

Geometry Requirements for ASSY® Screws

Loads (F) are applied to the wood.

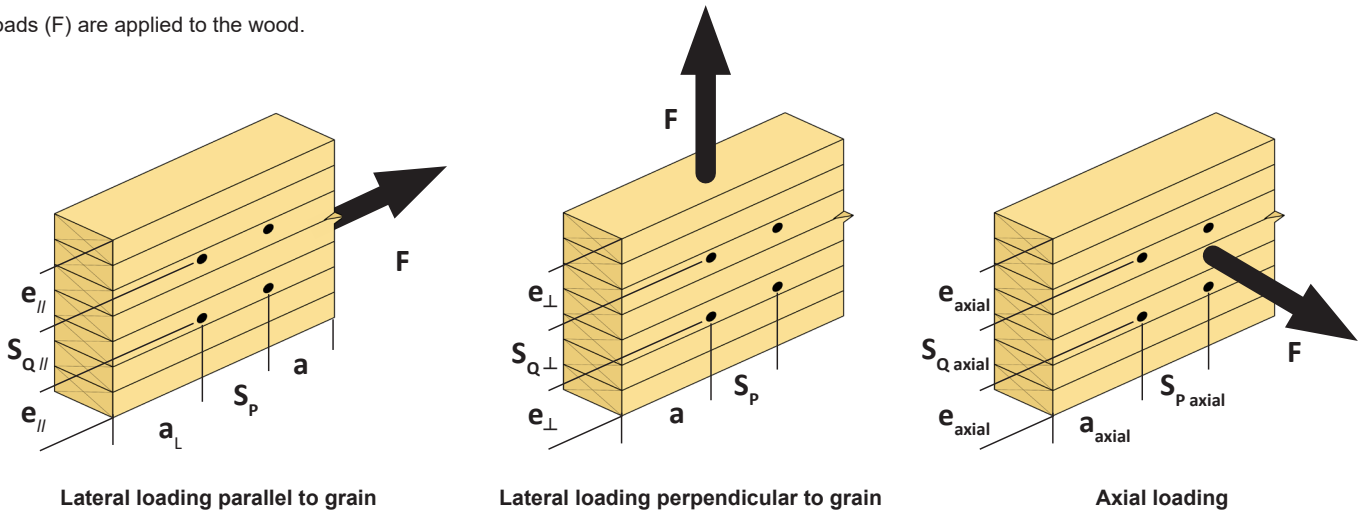

Geometry Requirements for ASSY® Screws

Table S.1.1, Timber Connection Geometry Requirements without Pre-drilling

		End Distance		Edge Distance			Spacing Between Fasteners in a Row		Spacing Between Rows	
		a/a_L	a_{axial}	$e_{//}$	e_{\perp}	e_{axial}	S_P	S_{Paxial}	$S_{Q\perp}/S_{Q//}$	S_{Qaxial}
Partial Thread	$G \leq 0.42$	10 D	10 D	5 D	10 D	5 D	5 D	5 D	5 D	5 D
	$0.42 < G \leq 0.55$	15 D	15 D	7 D	12 D	7 D	7 D	7 D	7 D	7 D
	D-Fir	22.5 D	22.5 D	7 D	12 D	7 D	10.5 D	10.5 D	7 D	7 D
Full Thread	$G \leq 0.42$	7 D	5 D	3 D	7 D	3 D	7 D	5 D	5 D	2.5 D
	$0.42 < G \leq 0.55$	7 D	5 D	3 D	7 D	3 D	7 D	5 D	5 D	2.5 D
	D-Fir	10.5 D	7.5 D	3 D	7 D	3 D	10.5 D	7.5 D	5 D	2.5 D

Notes:

1. According to ICC-ESR-3178 and ICC-EDR-3179
2. Tabulated values listed above must prevent splitting in wood. Shall splitting be observed a design professional must be consulted immediately.
3. Within a row, fasteners may be staggered up to 2-D to further reduce the potential for splitting. "D" is the major diameter of the fastener.
4. All connection design must meet all the relevant requirements of the Notes to the Designer section.
5. If pre-drilling is implemented, the spacing and edge distance requirements for lag screws as per NDS 2018 may apply.

Geometry Requirements in CLT for ASSY® Screws

Loads (F) are applied to the wood.

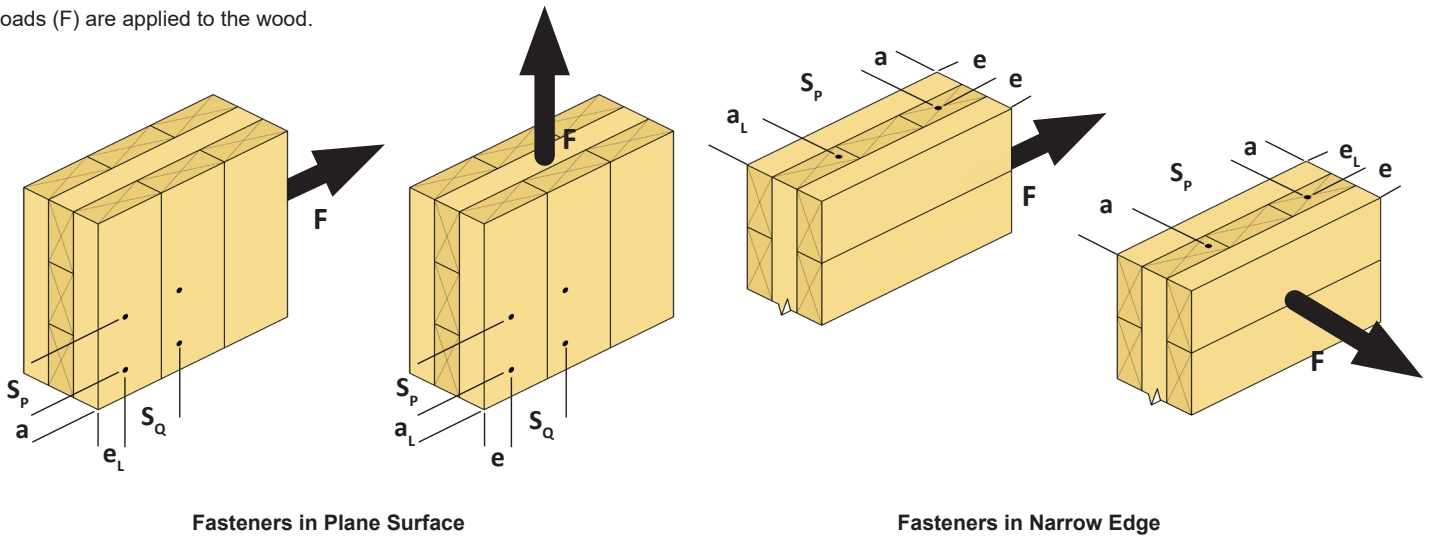

Table S.1.2, CLT Connection Geometry Requirements without Pre-drilling

CLT Plane	End Distance		Edge Distance		Spacing Between Fasteners in a Row	Spacing Between Rows
	a_L	a	e_L	e	S_P	S_Q
Fasteners in Plane Surface	6 D	6 D	6 D	2.5 D	4 D	2.5 D
Fasteners in Narrow Edge	12 D	7 D	6 D	3 D	10 D	4 D

Notes:

1. Spacing, end and edge distance requirements in the above tables were verified in testing.
2. The listed values are applicable when the CLT panel thickness is at least 10·D.
3. The minimum penetration depth of the screw into the narrow face of the panel should be at least 10·D. D is the major diameter of the fastener.
4. All connection design must meet all the relevant requirements of the Notes to the Designer section.
5. If pre-drilling is implemented, the spacing and edge distance requirements for lag screws as per NDS 2018 may apply.